

EXTREME SERIES **OWNER'S MANUAL**

Extreme 3500 ti

Extreme 5000 ti

Extreme 8000 ti

***Whisper* KOOL™**
The Coolest Thing In Wine Storage

Conforms to ANSI/UL Std 427

Certified to CAN/CSA Std C22.2 No. 120

WhisperKOOL

“Engineered, Designed and Assembled in the USA”

WhisperKOOL products are composed of parts and materials that were imported to the United States and then assembled into the final products in Stockton, California.

The WhisperKOOL split system condensers are sourced internationally.

Copyright © 2024. WhisperKOOL. All rights reserved.

WhisperKOOL copyrights this manual, the product design, and the design concepts, with all rights reserved. Your rights with regard to the hardware and manual are subject to the restrictions and limitations imposed by the copyright laws of the USA. Under copyright laws, this manual may not be copied, reproduced, translated, transmitted, or reduced to any printed or electronic medium or to any machine-readable form, for any purpose, in whole or in part, without the written consent of WhisperKOOL.

Every effort has been made to ensure that the information in this manual is accurate. WhisperKOOL is not responsible for printing or clerical errors.

WhisperKOOL reserves the right to make corrections or improvements to the information provided and to the related hardware at any time, without notice. Please visit our web site for the most current version of the WhisperKOOL manual and other literature.

Vinothèque and WhisperKOOL are registered trademarks, and ECE is a trademark of WhisperKOOL. All rights reserved.

Mention of third-party products is for informational purposes only and constitutes neither an endorsement nor a recommendation. WhisperKOOL assumes no liability with regard to the performance or use of these products.

TABLE OF CONTENTS

Introduction	2
Before You Start	3
Receiving & Inspecting the Unit	4
Quick Reference Guide	5
Controller Layout.....	6
Fan Speed & Unit Specifications.....	7
Preparing the Wine Cellar	8
Preparing the Unit for Installation	11
Through-the-Wall Installation	
Preparing the Installation Location.....	12
Optional Exterior Grille	13
Installing the Unit	15
Condensation Drain Line	17
Liquid Measuring Thermostat System (Bottle Probe)	18
Multi-Speed Fan Control	19
Unit Operation	20
Controller	
Functions	21
Extreme 3500ti, 5000ti, & 8000ti Wiring Diagram	22
Troubleshooting Guide	23
Maintenance Schedule	25
Technical Assistance & Accessories	26
Installation Terms & Conditions	27

INTRODUCTION

Customer Service

Thank you for purchasing a WhisperKOOL Extreme Series cooling unit. We strive to provide the highest-quality products and the best possible customer service. If you have any questions about your WhisperKOOL unit, please call us at 1-800-343-9463 or visit www.whisperkool.com.

Using the Manual

This manual is intended to assist in the proper installation and maintenance of the WhisperKOOL cooling unit. In order to ensure the longevity of your cooling unit, the equipment should be installed correctly and have a proper care and maintenance schedule. Please read and review this manual carefully and keep it for future reference.

What is the WhisperKOOL Cooling Unit?

The WhisperKOOL cooling unit is a specialized refrigeration unit designed for one purpose only: to maintain the optimal temperature and humidity levels conducive to the proper storage and aging of fine wines. It is a self-contained cooling unit designed to be used as a forced-air, through-the-wall unit.

How Does the WhisperKOOL Extreme Series Work?

The WhisperKOOL unit is especially designed to maintain optimal conditions for wine storage and aging. The unit is fully self-contained and can be installed through most walls. The unit is also capable of a more flexible ducted application, which allows the unit to be placed in an indoor remote site, resulting in a quiet airflow. The standard through-the-wall and ducted units are temperature-controlled via a bottle probe.

NOTE: The remote unit comes standard with a 50-foot bottle probe. Additional lengths are available from WhisperKOOL.

Temperature Setting

The WhisperKOOL cooling unit can be set at any temperature within the acceptable wine-aging range of 50–67°F. It is designed to create a differential of up to 55°F between the cellar and the ambient temperature (as long as the space to which the unit is exhausting does not exceed 110°F).

BEFORE YOU START

1. **Inspect the unit before installation.** If damage is found, please contact your distributor or WhisperKOOL Customer Service at support@WhisperKOOL.com.
2. The unit should **remain in an upright position for 24 hours** prior to operation.
3. The WhisperKOOL unit **requires a dedicated 115V, 20-amp circuit.** Use a surge protector with the WhisperKOOL unit. **Do not use a GFI** (ground fault interrupter) line.
4. The unit is designed to gently cool down the temperature of the cellar over time by cycling cooler and cooler air throughout. Test the unit prior to installation.
5. You are **REQUIRED** to **install a drain line** to remove condensation from the unit.
6. The WhisperKOOL unit is intended for use in **properly designed and constructed wine cellars.** Hire a professional wine storage consultant with a valid contractor's license to build your wine cellar.

Never try to open the WhisperKOOL unit, repair it yourself, or use a service company without WhisperKOOL's authorization. This will void your warranty.

If you encounter a problem with your WhisperKOOL unit, please refer to the Troubleshooting Guide. If you have any further questions, concerns, or need assistance, please contact WhisperKOOL Customer Service at 1-800-343-9463. Please be sure all testing has been completed prior to contacting Customer Service. Please have your results ready for your representative.

RECEIVING AND INSPECTING THE UNIT

Upon receiving your WhisperKOOL unit:

- Lift only at the designated hand-hold locations on the shipping container, or fully support the unit from underneath. A shipment may include one or more boxes containing accessories.
- Inspect the packaging for any obvious signs of damage or mishandling before opening the container.
- Note any discrepancies or visual damage on the bill of lading before signing.
- Place the box containing the WhisperKOOL unit on a tabletop to prepare it for testing prior to installation.
- Sit unit upright for 24 hours.

NOTE: WhisperKOOL units are assembled in the USA and tested prior to shipment.

- Review the packing slip to verify the package's contents.
- Check the model number to ensure it is correct.
- Check that all factory options ordered are listed.
- Check the box for the following:

3500ti / 5000ti / 8000ti
Extreme cooling unit <ul style="list-style-type: none">• (1) Extreme Series owner's manual• (18) Anti-microbial pan tabs• (1) Drain line brush• (1) Retractable bottle probe
Two-piece mounting bracket <ul style="list-style-type: none">• (2) Optional Filler Brackets
Accessory kit: <ul style="list-style-type: none">• (1) 8-foot power cord• (2) Mounting bracket insulation foam (6 feet)• (11) 1¾" standard screws• (5) 8-32 x ¼" Phillips machine screws• (1) ½" barbed "tee" fitting• (1) Drain line tube (½" ID clear plastic tubing, 10 feet)

If any items listed on the packing slip do not match your order information, contact WhisperKOOL Customer Service immediately.

Please leave the WhisperKOOL unit in its original box until you are ready for installation. This will allow you to move the product safely without damaging it. When you are ready to remove the product from the box, refer to the installation instructions.

TIP: Save your box and all packaging materials. They provide the only safe means of transporting/shipping the unit.

QUICK REFERENCE GUIDE

Front / Side View

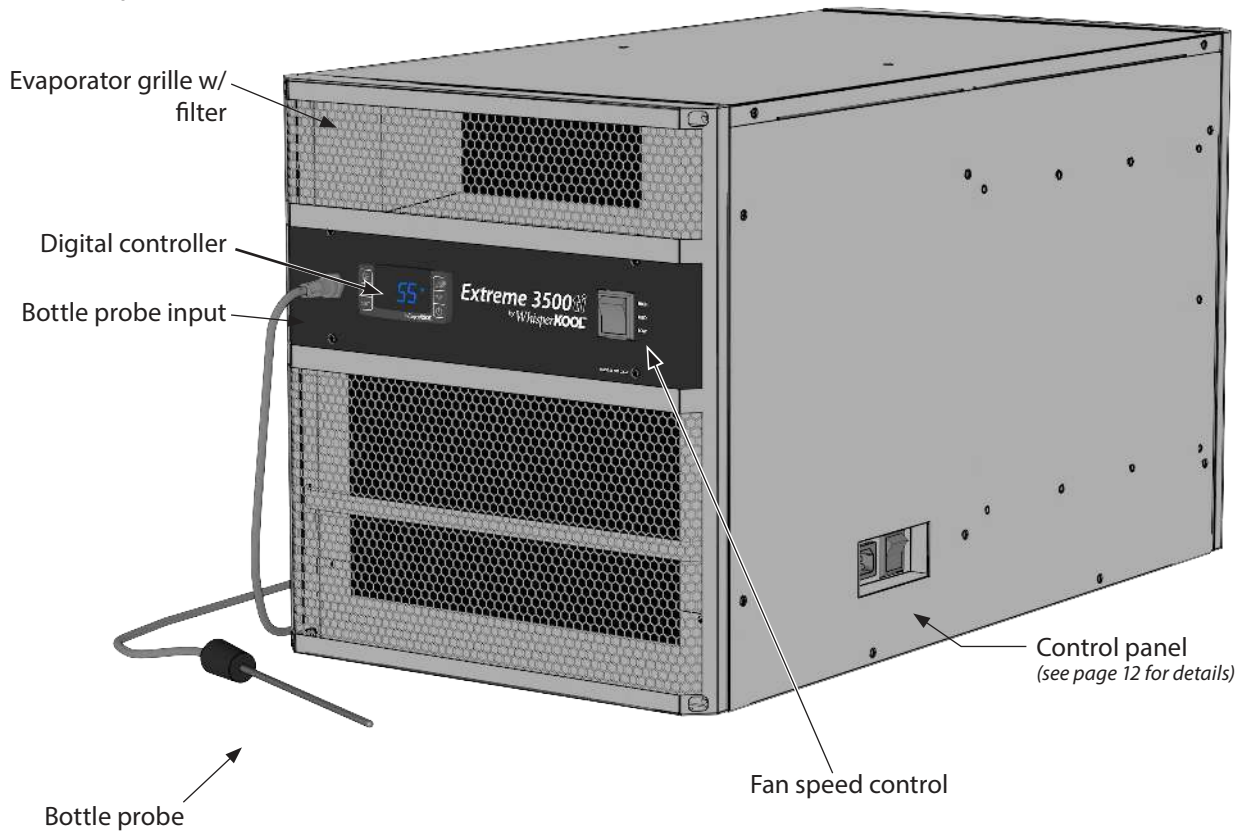

Rear / Side View

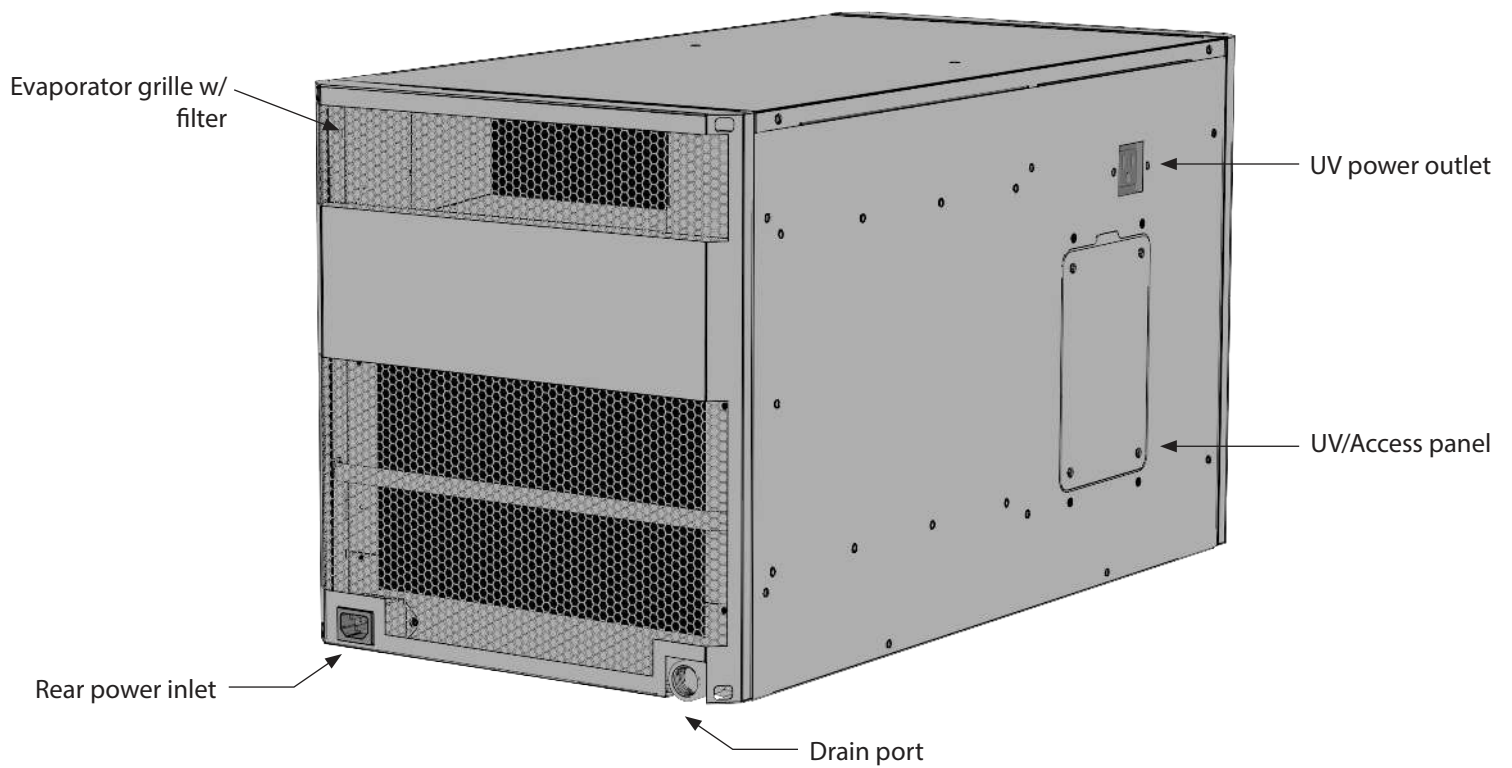

CONTROLLER LAYOUT

Note: 1 or 3-5 indicates the amount of time (in seconds) that the button must be pushed to activate the feature. Refer to page 20 for complete listing of buttons and symbols.

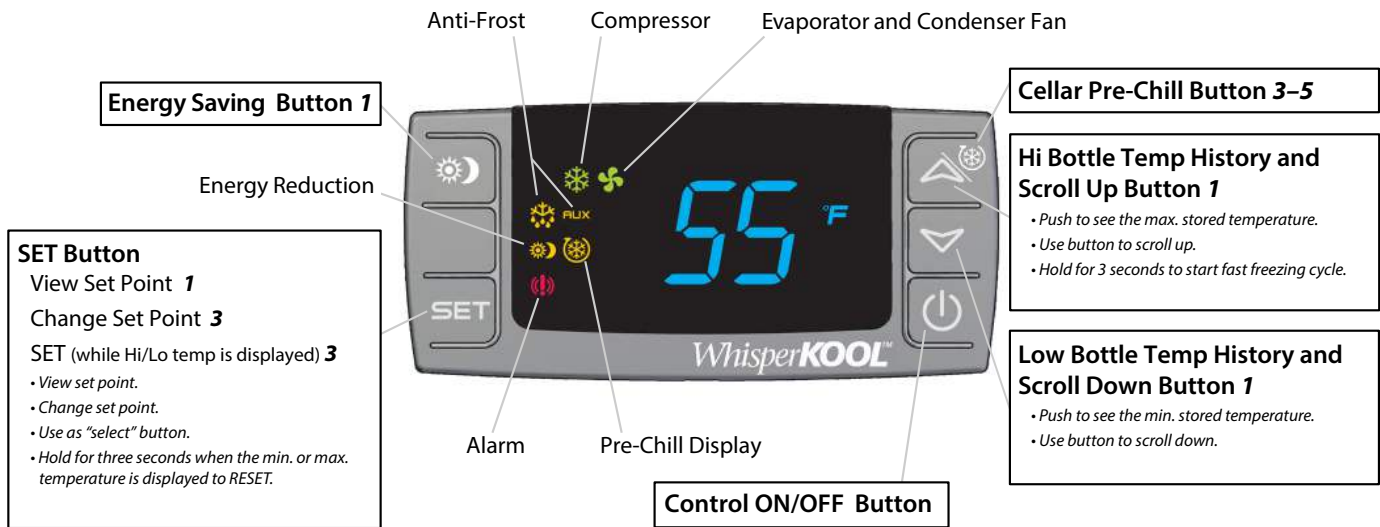

FAN SPEED

Fan speed selection is determined by the amount of heat that needs to be removed from the cellar and the type of installation (through-the-wall or fully ducted). Fan speed selection is based on the cellar size, insulation factor, door seal, and desired wine temperature. When initially installing the unit, set the fan speed to the **High** setting to quickly chill the wine cellar. Once the wine cellar reaches the desired temperature, a lower fan speed may be selected. In the event that the outdoor temperature rises above 90°F, (when exhausting to the outdoors) a higher fan speed may be required.

UNIT SPECIFICATIONS

	3500ti	5000ti	8000ti
Cellar Size*	800 cu. ft. when cellar is fully insulated and sealed with a proper vapor barrier	1250 cu. ft. when cellar is fully insulated and sealed with a proper vapor barrier	2000 cu. ft. when cellar is fully insulated and sealed with a proper vapor barrier
BTU/h with 85°F condenser air intake temperature	3175	4126	6131
Dimensions	28"L x 14.25"W x 15.75"H		28"L x 14.25"W x 22.5"H
Refrigerant	R-134a		
HP	1.25	1.62	2.4
Voltage Rating	115V (20-amp dedicated circuit required); 230V (subject to availability)		
Weight (lbs)	115		
Amps	9 (running amps)		
Drain Line	½" ID clear plastic tubing		
Installation	Through the wall		
Thermostat	Advanced digital controller, liquid-temperature-measuring bottle probe (retractable cable)		
Temp. Delta	Can maintain a 55°F cellar temperature temperature with up to 110°F condenser air intake temperature		
Outside Venting	Can be done if the outside temperature does not exceed 110°F; external grille is highly recommended		
Warranty	Two-year limited warranty (parts and labor)		

* Sizing the Unit to the Room

The specification chart will provide information on the unit's cooling capacity. There are circumstances in which a cellar design may require a larger unit due to preexisting design restrictions. Certain building materials such as glass, stone, or concrete may seem adequate but do not offer the insulation capacity required to maintain the optimum temperature for storing wine. We recommend purchasing a unit with a larger capacity to compensate for these design limitations. Undersized cooling units can lead to premature failure and/or prevent the system from reaching the desired set temperature. As a result, they are not covered under warranty.

PREPARING THE WINE CELLAR

The performance and life of your system is contingent upon the steps you take in preparing the wine cellar. Improperly preparing your enclosure or incorrectly installing your unit may cause unit failure, leaking of condensation, and other negative side effects.

It is highly recommended that you obtain the assistance of a wine storage professional.

Wine storage professionals work with licensed contractors, refrigeration technicians, and racking companies to build well-insulated, beautiful, and protective wine cellars. WhisperKOOL has put together some useful tips to assist in the installation process. Our recommendations are meant to act as a guide in the process of building a proper enclosure. Your intended location may have specific needs which we do not address.

Wall & Ceiling Framing

Build wine cellar walls using standard 2x4 or 2x6 boards and ceiling joists without violating local or state codes in your area. As a general rule, the thicker the walls and the higher the insulation value, the more consistent your cellar temperature will be.

Insulation

Insulation is **REQUIRED** in order to properly use WhisperKOOL products. It is vital that all walls and ceilings be insulated to keep the cellar temperature as consistent as possible during the summer and winter months. Standard fiberglass or rigid foam insulation is normally used in cellar construction; in some cases, “blown-in” insulation is used. The R-value, or quality of insulation, is determined by the rate at which heat passes through the insulation. The higher the R-value, the more resistant the insulation is to conducting heat, and the more consistent your wine cellar’s temperature will be. Using higher R-values in insulation will lower your operating costs and WhisperKOOL unit run time. (R-13 is the recommended minimum; R-19 is preferred for interior cellar walls, and R-30 for ceilings and exterior walls.)

Vapor Barrier

Water vapor creates its own pressure, separate from the ambient air pressure, and will intrude into colder/drier areas. A vapor barrier is **REQUIRED** in order to prevent the intrusion of water vapor and maintain the correct cellar temperature and humidity. It is recommended that 6-millimeter plastic sheeting be applied to the warm side of the cellar walls. The vapor barrier must also be applied to the outside walls and ceiling. If it is impossible to reach the outside, then the plastic must be applied from within the cellar. The most common method is to wrap the entire interior, leaving the plastic loose in the stud cavity so the insulation can be placed between each stud. All of the walls and ceiling must be wrapped in plastic for a complete vapor barrier.

In areas of high humidity, such as Southern and Gulf States, the vapor barrier will prevent infiltration of warm moist air. The moist air can cause mold to form, and standing water in drain pans promote microbial and fungal growth that cause unpleasant odors and indoor air quality problems. If mold is found, remove it immediately and sanitize that portion of the unit.

Note: High humidity significantly increases the heat load on the cooling system.

Any break in the vapor barriers (cut, nail hole, over-lapping, etc.) will cause a moisture leak and must be sealed. The electric conduit is a “duct” for vapor to travel in. The conduit should be caulked and sealed on the warm air end.

Mounting the Unit

The unit must be mounted within 18 inches of the ceiling in order to achieve sufficient cooling. As the room cools down, the warm air will rise to the ceiling. Mounting the unit high in the room will create a consistently cool environment by capturing the warm air and replacing it with cool air. Mounting the unit low in the room will result in a temperature variation in the room due to (a) the unit's inability to draw warm air down from the ceiling and (b) cold air settling to the floor.

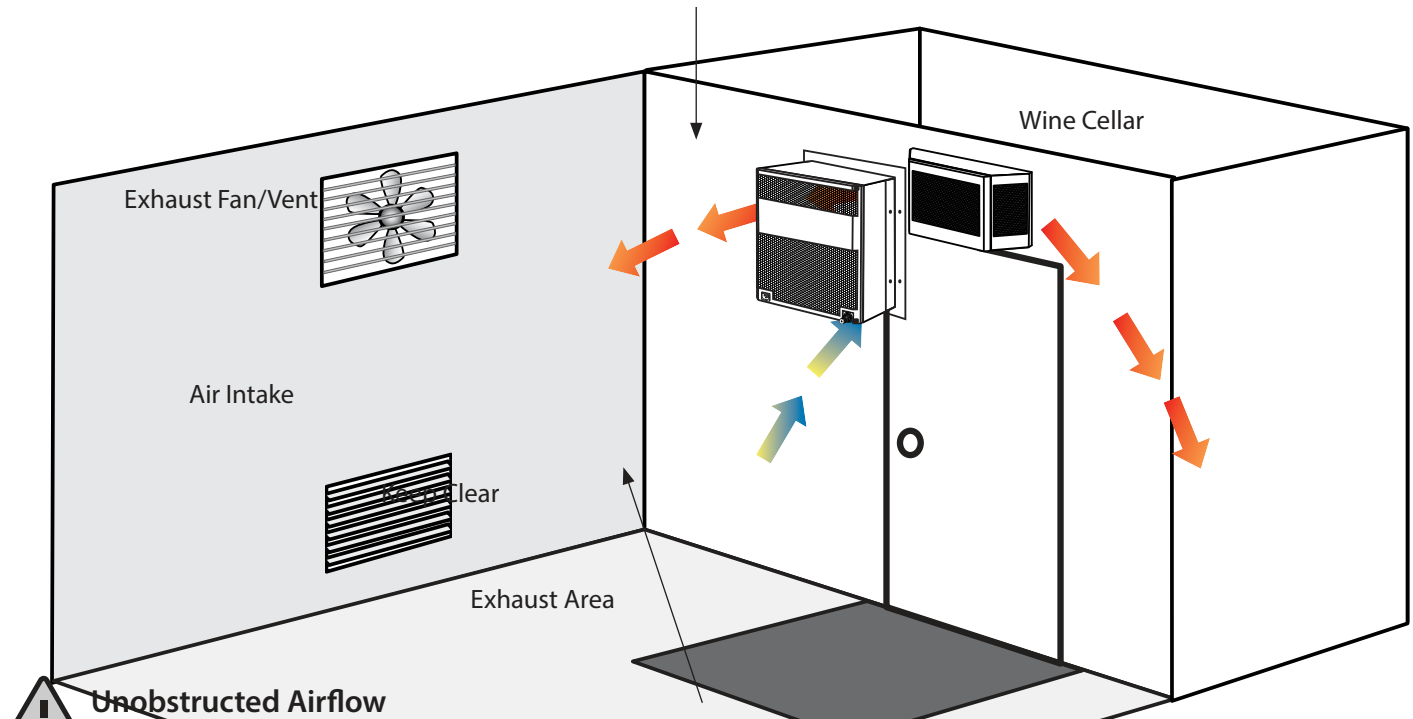

Unobstructed Airflow Unobstructed airflow to and from the unit is critical for the unit's overall performance and lifespan. Make sure there is a minimum of three (3) feet of horizontal clearance in every direction around the unit (five feet is ideal). The air blown by the fans needs to circulate and either dissipate or absorb heat from the space. The system will operate more efficiently with a greater amount of air to exchange.

NOTE: Do not attempt to mount the unit in a wall recess or attempt to camouflage or cover the unit with any sort of aftermarket grille, accessory, etc. This can restrict airflow, prevent the unit from working properly, and void the warranty. Please feel free to call WhisperKOOL Customer Service with any questions or concerns regarding installation requirements.

Door and Door Seal

An exterior-grade (1¾") door must be installed as a cellar door. It is very important that weather stripping be attached to all four sides of the doorjamb. A bottom "sweep" or threshold is also required. The door must have a very good seal to keep the cool cellar air from escaping out of the cellar. **In cases where glass doors are used and the room size is close to the recommended unit size, the next larger size WhisperKOOL should be used.** This will compensate for the insulation loss due to the lower insulation rating of glass.

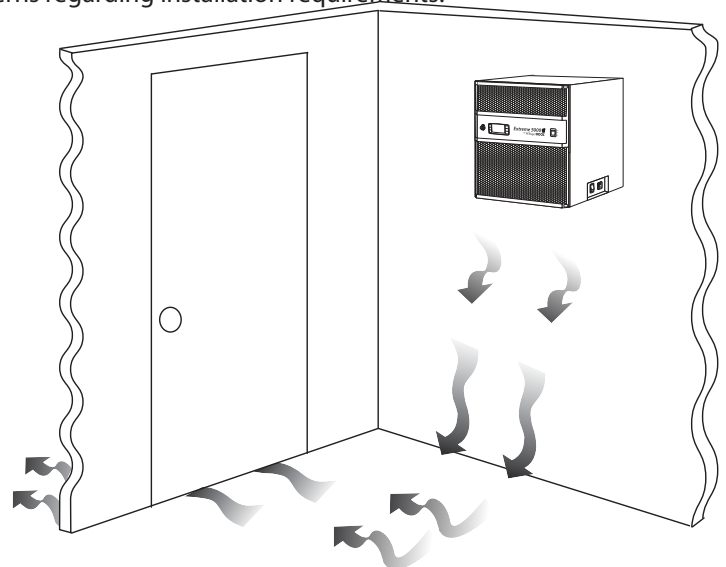

Ventilation

The necessity of dissipating heat away from the unit is critical to the unit's performance and cannot be overstated. As the unit operates and cools, a greater amount of heat is generated on the exhaust side of the unit. Adequate ventilation is required in order to dissipate heat away from the unit. If ventilation is inadequate, the exhaust will heat the area or room and adversely affect the unit's ability to cool. In some cases, it may be advisable to install a vent fan to dissipate heat from within the exhaust area. However, you must have a fresh air inlet as well. If your unit requires ducting, please contact WhisperKOOL to obtain a specially designed ducting plenum for the unit.

Using any other ducting system will void the warranty.

Note: If you are unsure whether you have adequate ventilation in your install location, please contact us to assess your specific installation at support@whisperkool.com or 1-800-343-9463.

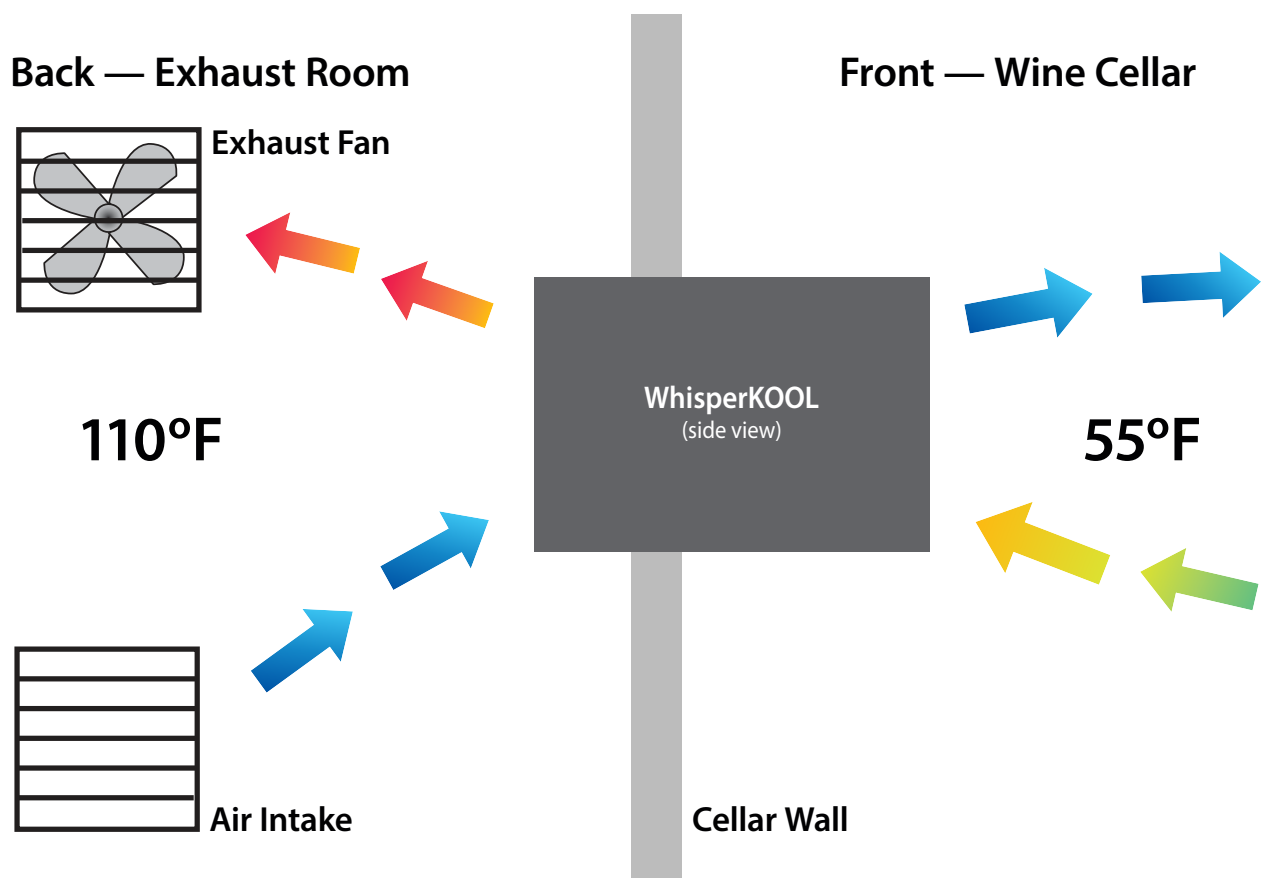

Ambient Temperature Factor

The cooling unit has the ability to cool a wine cellar efficiently to 55°F as long as the ambient temperature of the area that it is exhausting to does not exceed 110°F. Therefore, you want to exhaust the unit in a room which will not exceed 110°F. Without proper heat dissipation the unit will not have the capacity to keep the wine at a desirable 55°F.



WARNING! Allowing your unit to operate in high ambient temperatures for extended periods of time will greatly decrease the life of your unit and void your warranty.



PREPARING THE UNIT FOR INSTALLATION

The WhisperKOOL Unit requires a dedicated 115V, 20-amp circuit. The unit draws a large amount of amps during its initial startup. By designating a dedicated circuit breaker, you will guarantee the unit has enough power to run effectively. Contact an electrician for assistance with the installation of this dedicated electrical circuit.

The unit must sit upright for 24 hours prior to installation. To prepare the unit for installation:

- Remove unit from box.
- Match the electrical outlet to the plug provided on the WhisperKOOL unit.
- Provide a dedicated circuit and wiring for the unit (see above).
- Provide a weatherproof plug for units connected outside.

Power surges and spikes can damage sensitive electrical equipment. WhisperKOOL recommends plugging the unit into a surge protector or power conditioner in order to protect your system. As outlined in our terms and conditions, power surges and spikes are not covered under warranty.

We recommend that you do not use a GFI (ground fault interrupter) with this product.

The unit is equipped with two power inlets. One is located on the right side of the unit (inside of the cellar), and the other is located on the rear of the unit (outside of the cellar). Use the selector switch located on the right side of the unit to select which power inlet you would like to use. If you would like to plug the unit into a socket outside of the cellar, set the selector switch to rear. If you would like to plug the unit into a socket inside of the cellar, set the selector switch to the front position. When placed in either position, power can only enter the unit utilizing the power inlet you've selected.

In case the unit should lose power, check the home/main circuit breaker. If the unit does not respond properly, refer to the Troubleshooting Guide.

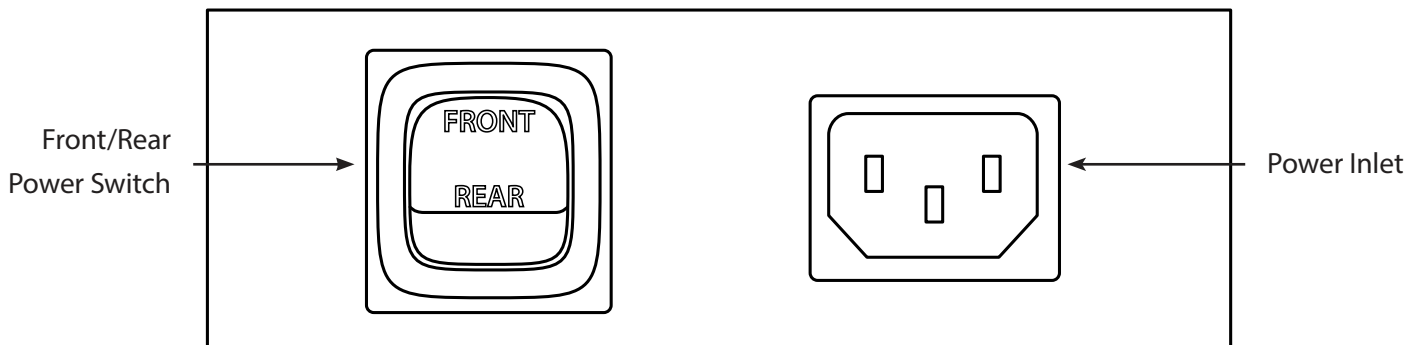

PREPARING THE INSTALLATION LOCATION

Minimum Tools Needed:

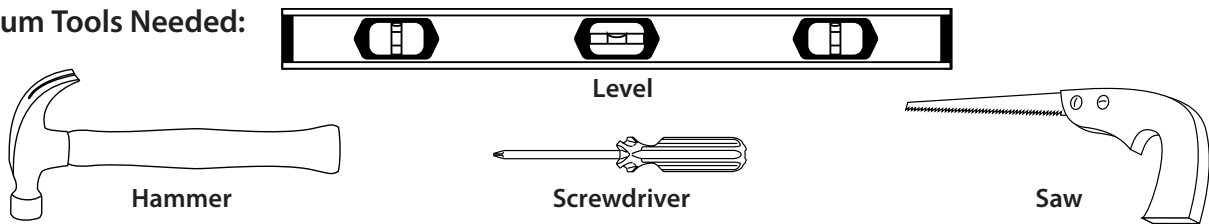

3500/5000ti Cut-Out Dimensions: 14.5"W x 16" H

8000ti Cut-Out Dimensions: 14.5"W x 22.75" H

Locate the desired installation location (no more than 18 inches from the ceiling). Using a stud finder, locate the studs on either side of the center point and mark them with vertical lines.

Using a level and a pencil, mark a horizontal line on the wall between the two studs, no less than 1½ inches and no more than 18 inches from the ceiling.

Using a ruler or measuring tape, measure 16 inches down (3500ti & 5000ti) or 22.75 inches down (8000 ti), and mark another horizontal line parallel to the first one.

Using a saw, cut along the uppermost horizontal line until your saw reaches the stud. Turn the saw around, inserting it into the cut that has just been made, and cut toward the opposite stud so that there is a clean horizontal cut between the two studs. Be careful not to cut into the studs themselves.

Make the second horizontal cut from stud to stud on the line 16 inches below the first cut.

Once the horizontal lines have been cut, make vertical cuts using the inside edge of the studs as a guide. Once both vertical cuts have been made, there should be rectangular hole in the sheetrock. Make the same hole on the other side of the wall. Using a nail, mark all four corners of the first hole by making nail holes through the sheetrock. Connect the holes with a pencil mark and cut on the other side of the wall.

Sheetrock alone cannot support the weight of a 96-lb cooling unit. Therefore, it is necessary to frame the hole that has just been cut with upper and lower supports. These supports also provide solid material for the mounting bracket screws.

Using two 2x4s (14.5 inches in length) and eight 6d nails, secure the upper and lower supports to the right and left studs, just inside the sheetrock. Make sure that the internal height remains at 16 inches (3500ti & 5000ti) or 22.75 inches (8000 ti) so that the WhisperKOOL unit will fit snugly through the framed cut-out.

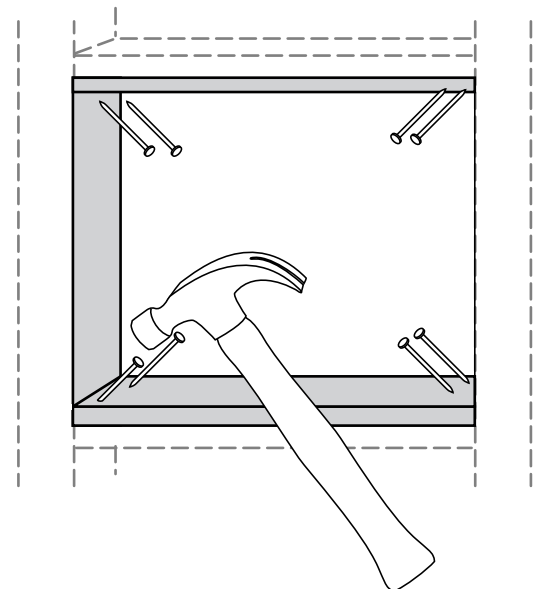
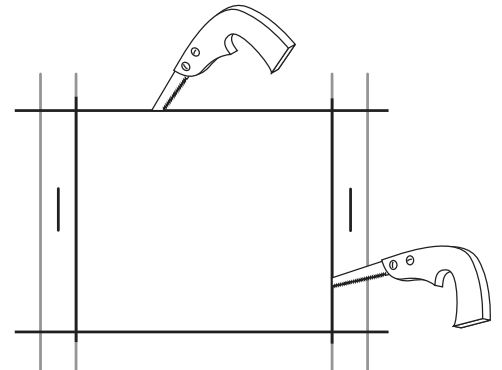
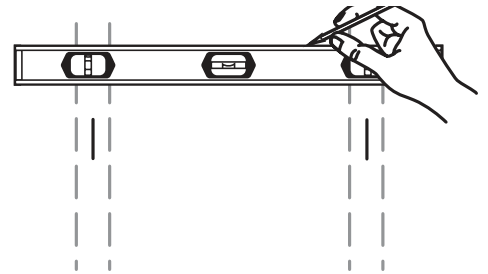

OPTIONAL EXTERIOR GRILLE

The exterior grille is required on all installations where the exhaust side of the unit is exposed to the outdoors (i.e., rain and other adverse weather conditions).

Non-Flush Installation

Install the unit according to the standard through-the-wall procedure. After the unit is installed, place the exterior grille over the exhaust side filter grille and align the screw holes on the sides of the unit. Use the supplied pan-head screws to fasten the grille to the unit.

Flush Installation

If utilizing the flush installation, simply slide the exterior grille cover over the mounting bracket side flanges. Align the screw holes on the sides of the unit. The mounting screws will secure through the center holes on the mounting bracket flanges. Use the supplied pan-head screws to fasten the grille to the unit.

You are required to use the 1/2" pan-head screws provided. Do not drill holes into unit.

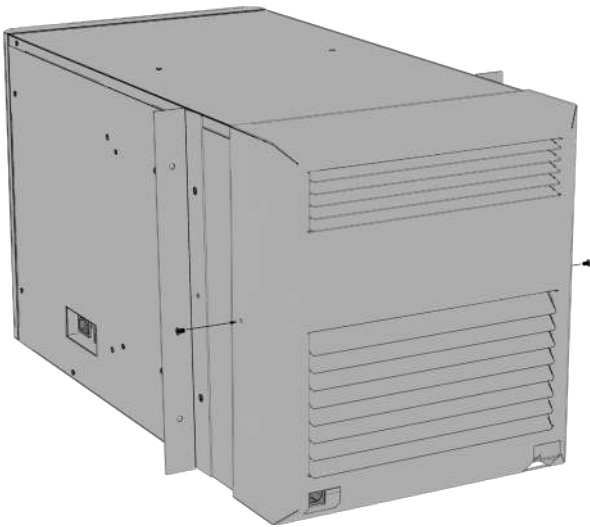

Non-Flush Installation

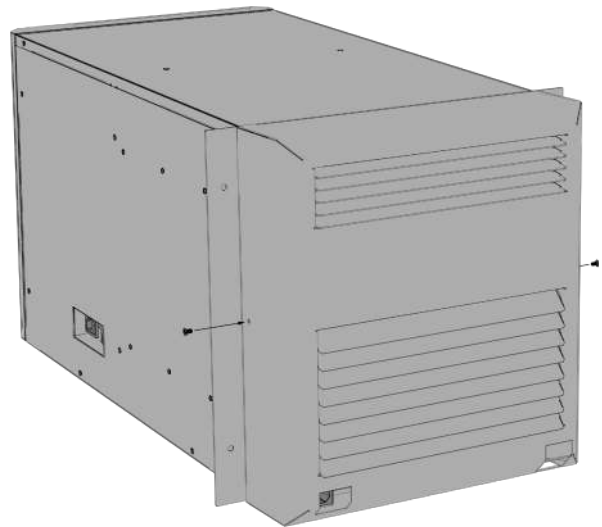

Flush Installation

PREPARING THE UNIT FOR INSTALLATION

A two-piece mounting bracket is used to secure the unit to the wall studs. Two optional filler brackets can also be installed to frame around the top and bottom of the unit.

The mounting holes on the unit have been designed to hold the unit at a two-degree (2°) angle. This helps project air into the space and aids in condensate drainage.

Applying Insulation Tape

Locate the foam tape included in the accessory kit. Cut strips to match the length of the mounting brackets. Peel off backing material and install foam tape against wall-facing side of brackets. Foam tape needs to be placed on the bracket surfaces which will be in direct contact with the wall.

Mounting Bracket Installation

Select your desired mounting bracket location (see diagram below). This location determines the depth of the installation. For example, position #1 keeps most of the unit out of the cellar while position #4 sets the back of the unit near flush with the exterior wall. Secure the brackets to the sides of the cooling unit using the provided 1/4" Phillips screws. Do not use any other screws to secure the brackets to the unit.

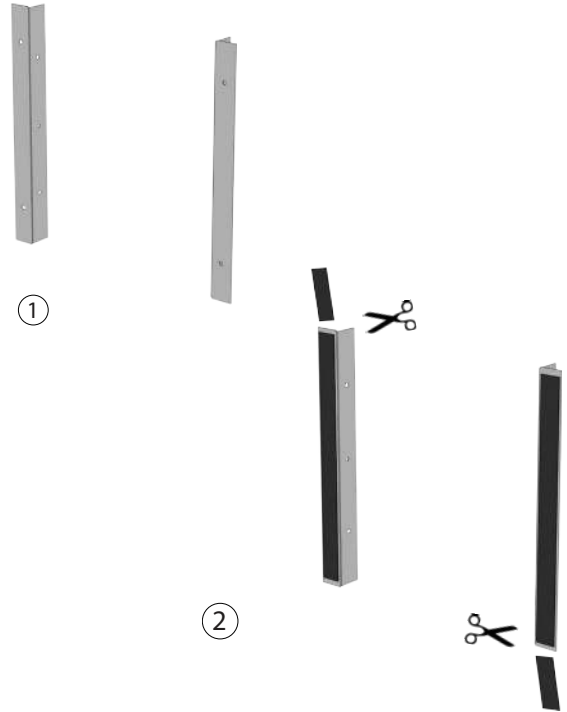

If you are installing through an exterior wall, please review the next page for specific instructions on exterior grill installation.

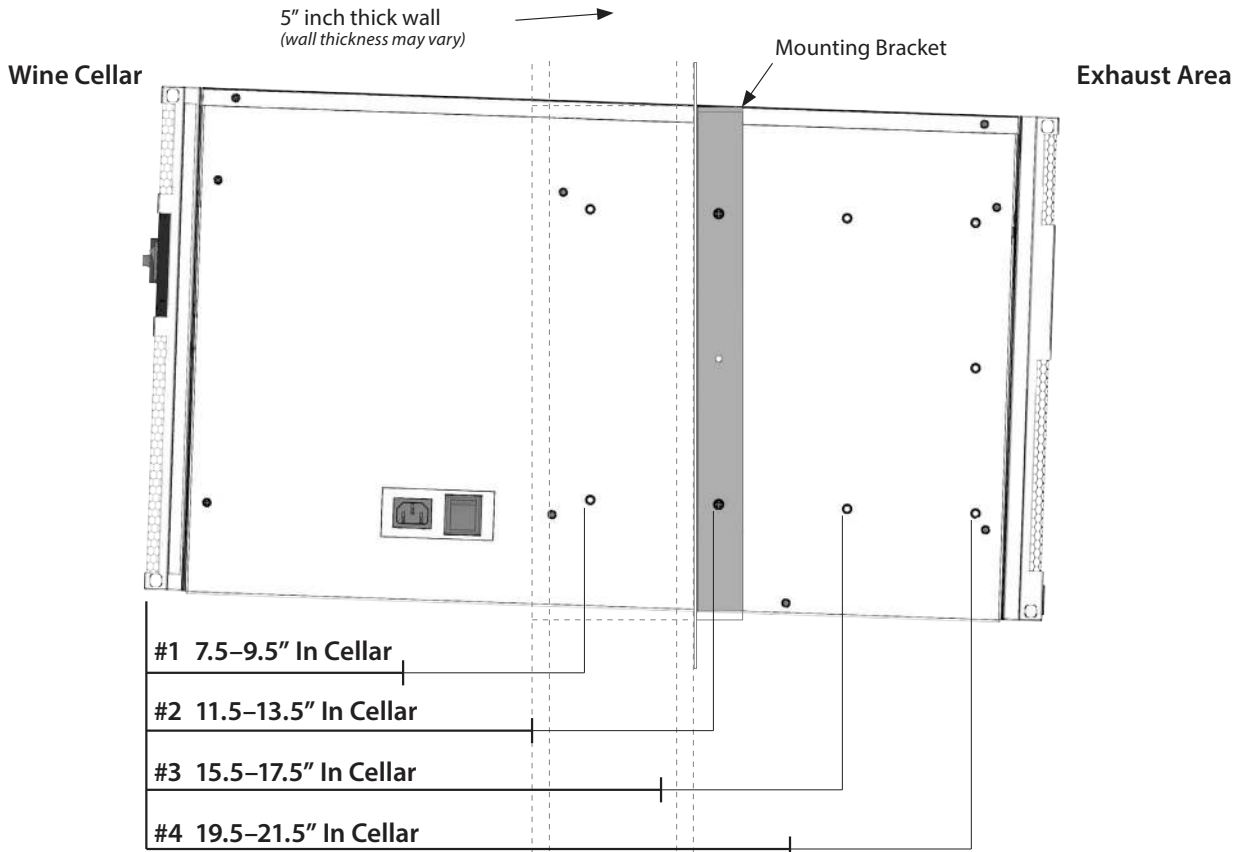



INSTALLING THE UNIT

Slide the unit from the outside wall into your wine cellar with the outer flange flush with the wall. Secure the flange to the wall using the pre-drilled holes. The 1 $\frac{3}{4}$ " screws should penetrate the studs as well as the upper and lower supports to provide adequate support for the WhisperKOOL unit (see illustration). Seal all cracks and gaps around the WhisperKOOL Extreme unit with an air-tight sealant or caulking to prevent air leakage.

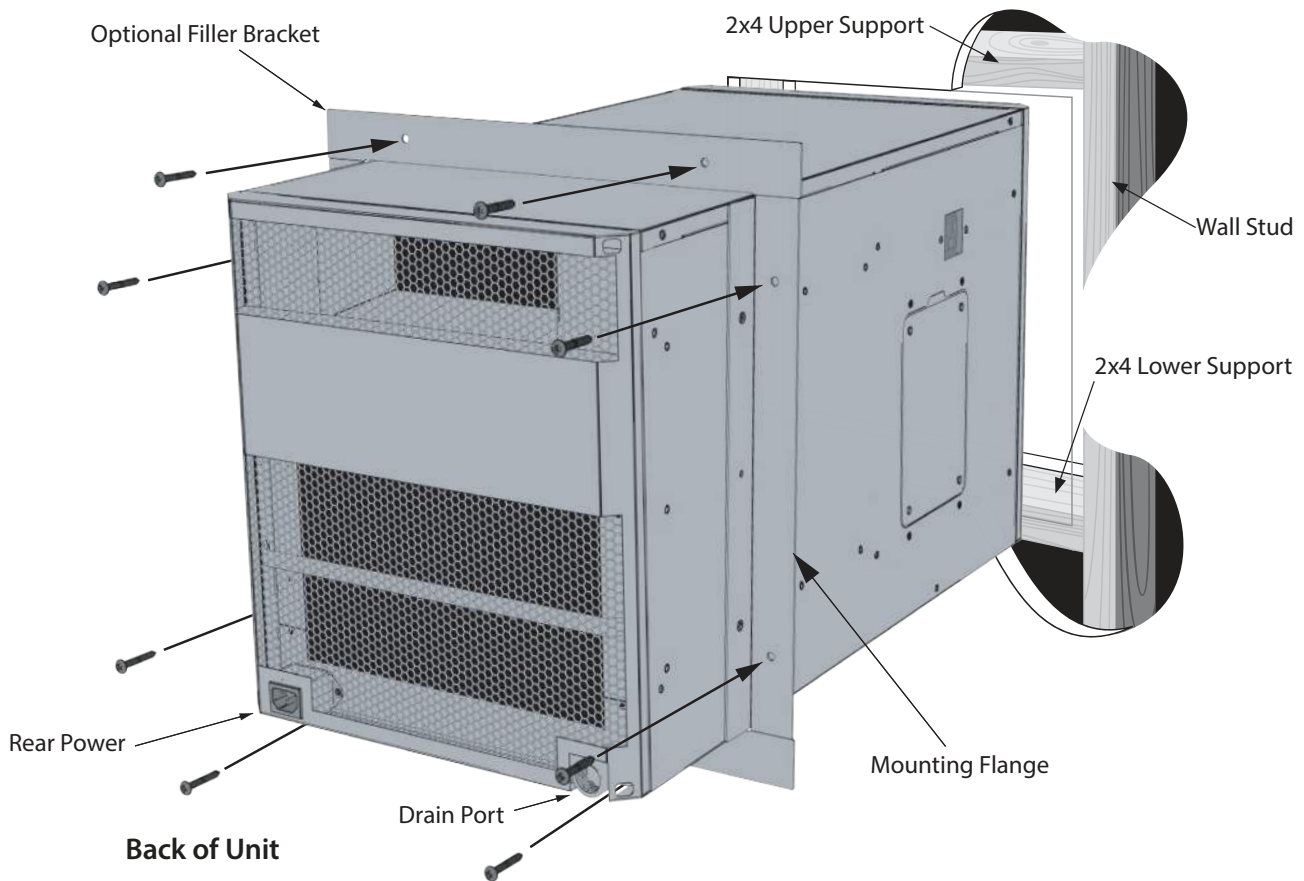
Note: If you use decorative moulding, it should be attached to the walls and *never* to the cooling unit itself. The moulding itself should be removable in case the unit needs servicing.



Button/Symbol	Normal Functions						
SET BUTTON 	<p>Press the SET button once and it will display the setpoint. After approximately 5 seconds, the display will return to normal operation and display the bottle probe temperature.</p> <table border="1"> <tr> <td>Change Setpoint</td> <td>Press and hold the SET button for 3–5 seconds until the setpoint is displayed and the °F symbol blinks. Press the UP or DOWN ARROW buttons to select a new setpoint. Press the SET button once and the setpoint numbers and the °F on the display will blink to confirm the new setting.</td> </tr> <tr> <td>Reset Temp. History</td> <td>Press and hold the SET button during the display of the Hi/Lo (temperature data history). Hold button until “rSt” blinks on display, erasing the current time and temperature data.</td> </tr> <tr> <td>CPSM</td> <td>Press the SET and the DOWN ARROW buttons simultaneously for 10–15 seconds to enter CPSM (Customer Preference Selection Mode).</td> </tr> </table>	Change Setpoint	Press and hold the SET button for 3–5 seconds until the setpoint is displayed and the °F symbol blinks. Press the UP or DOWN ARROW buttons to select a new setpoint. Press the SET button once and the setpoint numbers and the °F on the display will blink to confirm the new setting.	Reset Temp. History	Press and hold the SET button during the display of the Hi/Lo (temperature data history). Hold button until “rSt” blinks on display, erasing the current time and temperature data.	CPSM	Press the SET and the DOWN ARROW buttons simultaneously for 10–15 seconds to enter CPSM (Customer Preference Selection Mode).
Change Setpoint	Press and hold the SET button for 3–5 seconds until the setpoint is displayed and the °F symbol blinks. Press the UP or DOWN ARROW buttons to select a new setpoint. Press the SET button once and the setpoint numbers and the °F on the display will blink to confirm the new setting.						
Reset Temp. History	Press and hold the SET button during the display of the Hi/Lo (temperature data history). Hold button until “rSt” blinks on display, erasing the current time and temperature data.						
CPSM	Press the SET and the DOWN ARROW buttons simultaneously for 10–15 seconds to enter CPSM (Customer Preference Selection Mode).						
ALARM 	The Alarm symbol is shown when the unit encounters an issue that needs attention, the displayed alarm codes are explained below.						

ALARM CODES

Message	Cause	Solution
“P1”	Bottle probe is unplugged	Attach bottle probe to unit
	Faulty bottle probe connection	1. Check bottle probe attachment at circular connector 2. Check bottle probe connection at the back of controller
	Defective bottle probe	Replace the bottle probe
“P2”	Faulty evaporator probe connection	Check evaporator probe connection at green terminal block on the back of controller
	Defective evaporator probe	Replace the evaporator probe
“HA”	Faulty controller	Contact Customer Service at 1-800-343-9463
“LA”	The bottle probe is sensing a temperature that is 4° below the setpoint	Allow the room to warm up which will increase the temperature of the wine
	Defective bottle probe	Replace the bottle probe
“POF”	The controller is locked	Hold UP and DOWN ARROW buttons for 3–5 seconds to disable. “PON” will display.

CPSM (CUSTOMER PREFERENCE SELECTION MODE)

Press and hold the SET and DOWN ARROW buttons for 10–15 seconds to enter the CPSM menu.

Fon <i>Humidity Management/Enhancement</i>	The "fan on" setting is preset at the factory to zero minutes, which should provide adequate relative humidity for the cellar. Increasing the amount of "fan on" time will increase the Humidity Enhancement (%RH). Adjustments should be made in increments of 5, with a maximum of 15 and a minimum of 0. After any adjustment to Humidity Enhancement, you should wait a minimum of three days before making any additional adjustments. This will allow the cellar sufficient time to acclimate to the new setting.
FOF	The "fan off" time is normally set to 15 minutes. This parameter should not be adjusted, as it simply provides an OFF cycle time for the fan during the compressor's OFF cycle.
CCS	<i>Cellar Pre-Chill Setpoint.</i> This parameter is set at 52°F, but can be adjusted to a setpoint between 50–67°F.
CCt	<i>Cellar Pre-Chill Duration.</i> This parameter is set to 6 hours, but can be adjusted to a setpoint between 0–23.5 hours.
Con/Cof	<i>Compressor On time (Con) and Off time (Cof) with a P1 Alarm.</i> These parameters are set at Con 40 min/Cof 10 min. In the event of a P1 Alarm, the compressor/refrigeration system automatically starts a predetermined ON/OFF cycle, which is controlled by the Con and Cof parameters. These parameters can be adjusted to maintain the desired bottle temperature.
HES	<i>Differential for Energy Reduction.</i> During the Energy Reduction mode, this parameter is set at 4°F above the setpoint. A decrease in this setting will lower the setpoint and an increase in this feature will raise the setpoint.

CONDENSATION DRAIN LINE

The condensation drain line tube is used to drain excess condensation from the unit to a proper discharge location. It is important that the drain line tube be properly connected in order to prevent leakage and other problems associated with excess condensation.

Failure to use the condensation drain line tube will void the warranty on the unit.

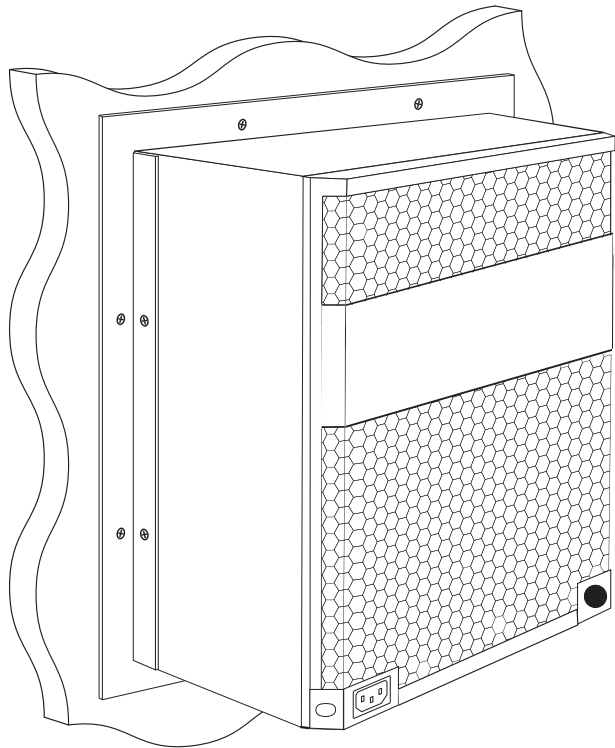

All units come with a drain line for additional removal of excessive condensate. It is mandatory to install the drain line with a "tee" fitting. During operation, the cooling unit will strip excess water from the air in order to maintain the proper level of humidity within the cellar. However, in extreme humidity, additional condensate will be removed. The drain line will prevent overflow and leaking by allowing for discharge of the additional condensate.



To prevent mold from growing, allow the drain line to hang above the water line.

Extreme Drain Line Installation

1. Wrap tee with Teflon tape one or two turns clockwise.
2. Next, thread the barbed tee into the drain port and rotate until tight. Make sure the barbed parts of the tee are vertical.
3. Next, attach the piece of 1/2" ID clear plastic tubing to the lower barb of the tee.
4. Every six weeks, disconnect the drain line from the tee. Remove the tee from the rear drain port and clean it. Then use the supplied drain line brush to clean the interior drain line. Use the drain line access door to drop a pan tab into the drip tray to prevent the buildup of microbial growth.

Black 1/2" tee

Drain line

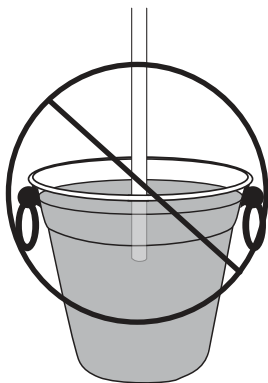

WRONG: Drain line is under water.

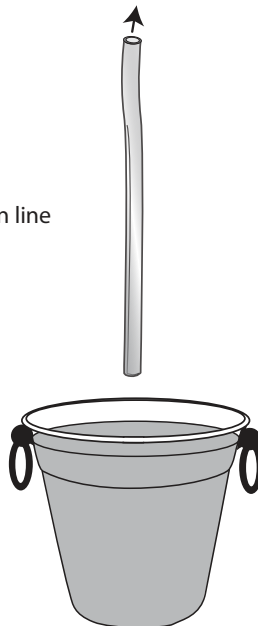

LIQUID-MEASURING THERMOSTAT SYSTEM (BOTTLE PROBE)

WhisperKOOL cooling units come with a liquid-temperature-measuring thermostat. The self-calibrating bottle probe contains a sensor which communicates back and forth with the thermostat. This results in a consistent temperature setting and accuracy. Wine should be kept at a very precise, controlled temperature and humidity. By measuring the liquid temperature rather than air, the unit will operate 75–80% of the time.

Setting up the Bottle Probe

1. Locate an empty wine bottle.
2. Fill it 75% full with room-temperature tap water.
3. Place bottle probe securely into bottle as seen in Figure 1.
4. Place bottle off to the side of the unit in your wine cellar, with the probe level.
5. To ensure a consistent temperature, place bottle probe approximately three (3) feet away from the air output and not in the flow of the air.
6. Connect the opposite end of the bottle probe wire to the circular connector on the front of the unit marked "BOTTLE PROBE." Twist the connector clockwise to lock it in place as seen in Figure 2.

It is recommended that the bottle be placed in a central location of your wine cellar. Avoid pulling too much on the probe cord. It may become disconnected, resulting in limited functionality of the unit.

Note: The thermostat can be set between 50-67°F.

Remember: The WhisperKOOL unit operates based on the temperature of the water. Do not be misled by thermostats which read air temperature. The air temperature in the cellar will be cooler than the liquid temperature of the wine while it is reaching its optimum balanced temperature.

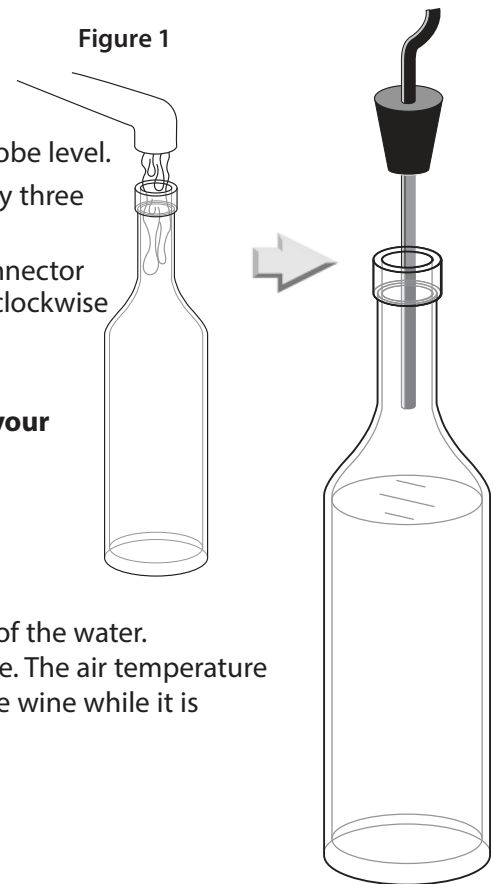
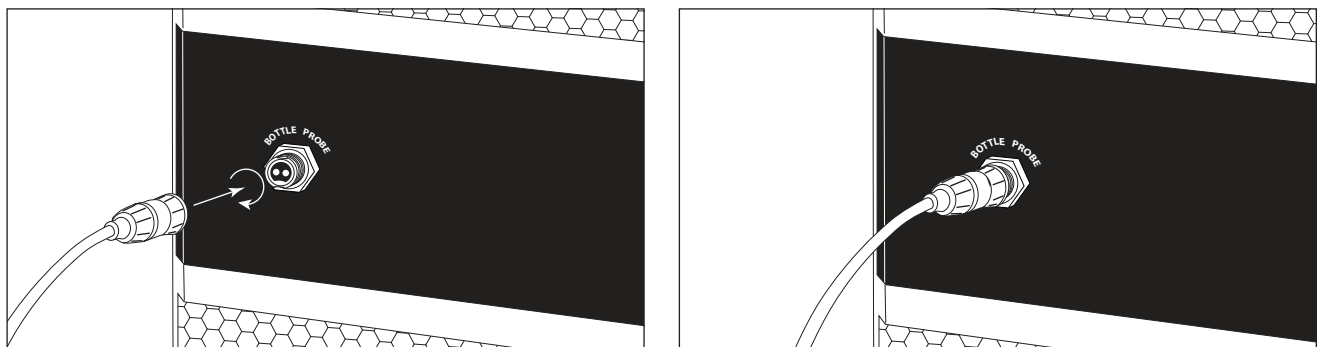

Figure 2



MULTI-SPEED FAN CONTROL

Designed for wine cellars up to 1000 and 2000 cubic feet, the Extreme 3500ti, 5000ti, and 8000ti feature multi-speed fans. These fans have a high setting for maximum performance in high-temperature (+110°F) environments and a low setting for super-quiet operation.

Fan Speed Selector Switch (Low/Med/High)

The cooling unit fans operate on three speed settings: **Low**, **Medium**, and **High**. For optimum sound and energy efficiency, select the lowest fan speed that will maintain the desired cellar temperature. If the relative humidity is low, a higher fan speed will cause less moisture to be removed during cooling. High speed is recommended for initial cellar cool-down, extreme temperature conditions, and ducted installations.

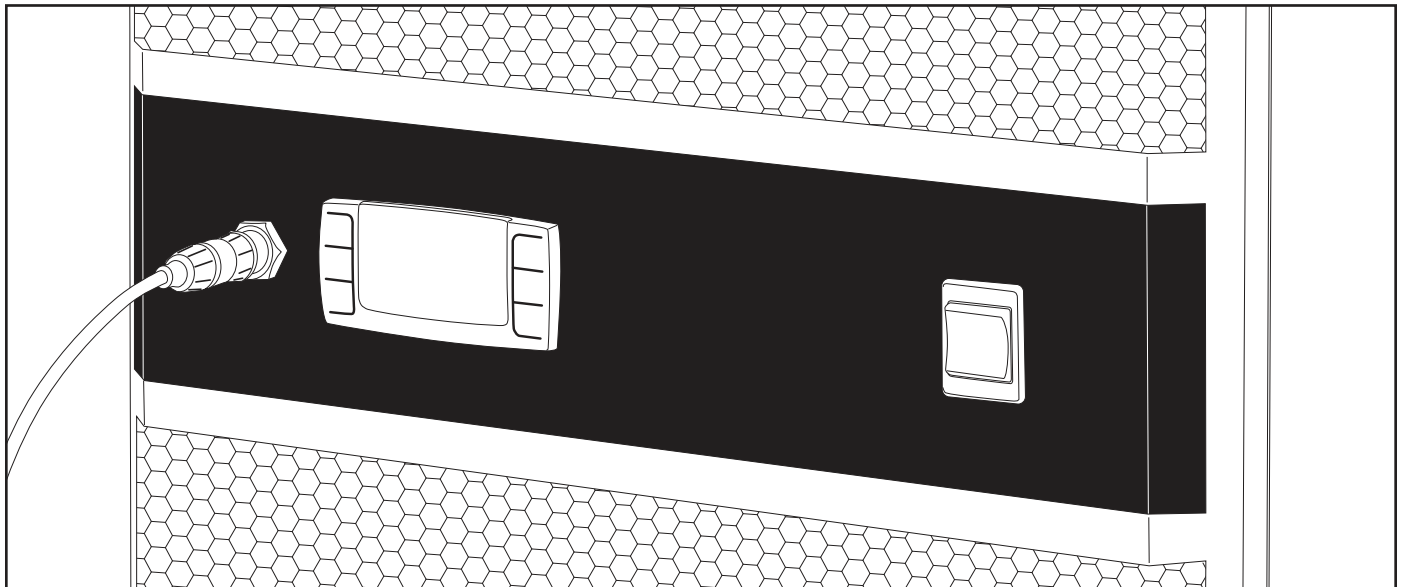

Fan speed selection is determined by the amount of heat that needs to be removed from the cellar and the type of installation (through-the-wall or fully ducted). Fan speed selection is based on cellar size, insulation ratings, door seals, and the desired wine temperature. When initially installing the unit, set the fan speed to the **High** setting to quickly cool down the cellar. Once the wine cellar reaches the desired temperature, a lower fan speed may be selected. In the event that the outdoor temperature rises above 90°F (when exhausting to the outdoors), a higher fan speed may be required.

Speed Selection	3500ti			5000ti			8000ti		
	Low	Med	High	Low	Med	High	Low	Med	High
Airflow (CFM)	147	180	256	147	180	256	274	318	333
Sound (dBA* In Cellar / Out of Cellar)	51/51	58/57	66/65	51/51	58/57	66/65	57/57	59/59	60/61
Cooling Capacity (BTU/h)	2374	2514	3175	3099	3453	4126	5140	5606	5760

* To give you a feeling for decibels, a food blender at 3 ft. is 90 dBA, a garbage disposal at 3 ft. is 85 dBA, a vacuum cleaner at 10 ft. is 75 dBA, normal speech at 3 ft. is 79 dBA, a dishwasher in the next room is 55 dBA, and a quiet night is 35 dBA.

SYSTEM OPERATION

Initial Start-Up

When power is applied to the unit, the snowflake symbol will be displayed (if unit is calling for cooling). There may be a delay of up to 60 seconds before the evaporator fan turns on. When the evaporator fan is activated, the fan symbol will display.

APST (Advance Product Safety Technology) is a temperature control feature for the evaporator fan that comes standard with all WhisperKOOL units. APST ensures that in the possible event of a cooling deficiency, the heat from the indoor fan will not raise the temperature of the wine cellar, which could otherwise have an adverse effect on the wine-aging process.

Setpoint

The setpoint is set at the factory (WhisperKOOL) to 55°F. It can be adjusted by the customer between 50–67°F in one-degree increments.

Humidity Features

The Fon ("fan on") function is an adjustable feature which allows the customer the convenience of reintroducing some of the humidity removed by the fan coil during the cooling process. When the bottle probe has reached the setpoint (all units are shipped with the setpoint of 55°F and a differential of 1°), the compressor and the condenser fan will turn off, but the indoor fan will continue to run for about 5 minutes to reintroduce any moisture from the evaporator coil. All units come with this feature turned off. If low humidity is a problem, increasing "fan on" time will raise the humidity level.

Anti-Short Cycle

The Anti-Short Cycle ensures that the compressor will remain off for a period of three minutes after the unit has reached the setpoint to allow the pressure in the refrigeration unit to equalize prior to starting the compressor.

Anti-Frost Cycle (defrost)

When the evaporator probe senses a temperature of 26°F for five minutes, the unit will go into an Anti-Frost Cycle. This will shut down the compressor and allow the evaporator and condenser fans to run to evaporate any frost accumulation on the coil. The compressor will remain off until the evaporator coil reaches 40°F, or for a maximum of ten minutes. The unit will then return to normal operation.

Bottle Probe Failure Protection

In the event that a bottle probe should fail, the APST (Advance Product Safety Technology) will automatically transition the compressor to a pre-determined time cycle (based on detailed laboratory testing), which will ensure that the product is kept within a safe temperature range.

Display

The bottle probe temperature is displayed by default. "Def" is displayed during Anti-Frost. The air sensing probe and evaporator probe temperatures can be accessed by pushing the SET button and scrolling through "PB1" (bottle probe), and "PB2" (evaporator probe).

Safety Features

Once the compressor relay is de-energized the controller must wait five minutes before reenergizing the relay. This prevents the compressor from repeatedly turning off and on. If the unit is calling for cooling during this time, the compressor symbol will blink, indicating that cooling is needed but the control is waiting for the Anti-Short Cycle delay.

In the event of a faulty bottle probe, the compressor will cycle off for 10 minutes and on for 40 minutes. "P1" will be displayed on the screen.

Alarms

See **Alarm Codes** in the Controller Functions chart on page 21.

CONTROLLER FUNCTIONS

Energy Reduction









Display Set Point



High Temp Pre-Chill

Low Temp

ON/OFF

Button/Symbol	Normal Functions
ON/OFF 	<p>The ON/OFF button allows the customer the convenience of turning the refrigeration unit ON or OFF from the control panel. This feature does not disconnect power from the unit. In order for the power to be shut off from the unit, the power cord must be unplugged from the wall outlet.</p>
UP/DOWN ARROWS  	<p>Use these buttons to scroll through the CPSM (Customer Preference Selection Mode) menu. The arrow buttons also display the highest and lowest temperatures sensed by the bottle probe. They can be easily reset to reflect current temperatures.</p> <ol style="list-style-type: none"> 1. Press the UP ARROW or DOWN ARROW button once and the highest or lowest temperature (Hi/Lo) sensed by the bottle probe will be displayed. 2. To reset the Hi/Lo, press and hold the SET button when the Hi/Lo value is displayed on the display, continue to hold the SET button until "rSt" appears on the display and then blinks. This will erase the past recorded temperature data history and start recording from the current time and temperature. 3. The Hi/Lo feature should be reset at initial startup and after the cellar or cabinet has reached its normal operating temperatures, generally 55°F.
CELLAR PRE-CHILL (CPC)  	<p>Activate the CPC feature by pressing the UP ARROW button for 3–5 seconds until the CPC logo appears on the display. The CPC feature can be terminated by pressing the UP ARROW button for 3–5 seconds. The feature will self-terminate after six hours.</p> <p>The CPC feature may be used to pre-chill the cellar prior to loading it with warm product. The feature will shift the setpoint down to a lower setting of 52°F, for the next 6 hours. After the six-hour time period, the setpoint will automatically return to the original setpoint.</p> <p>The CPC feature can be conveniently adjusted to the customer's specific needs, by accessing the CPSM (Customer Preference Select Mode). See CPSM Instructions on the following page.</p>
ENERGY REDUCTION (ER) 	<p>The ER feature is activated by pressing the ER button once. The ER symbol (a sun and a crescent moon) will appear on the display. The ER feature reduces energy consumption by shifting the setpoint up by four degrees. This allows cooling unit to run for shorter periods of time, resulting in a reduction in energy cost. The ER feature allows for energy savings at any time — during periods of high ambient temperatures, vacations or business travel.</p> <p>To deactivate the ER feature, press the ER button one time, and the ER logo will turn off. The ER feature can be conveniently adjusted to the customer's specific needs. See CPSM Instructions on the following page.</p>
ANTI-FROST CYCLE  AUX	<p>The Anti-Frost Cycle is automatically activated when the evaporator registers a temperature of 25°F for a period of five minutes. During this cycle the compressor and condenser fans will turn off while the evaporator fans continue to run. Once the temperature of the evaporator gets back up to 40°F the cycle will deactivate and the unit will revert back to normal operating conditions.</p> <p>At the beginning of the cycle the AUX symbol will display and the  symbol will flash. When the cycle begins properly, the  symbol will be steadily illuminated.</p>

EXTREME 3500ti, 5000ti, & 8000ti WIRING DIAGRAM

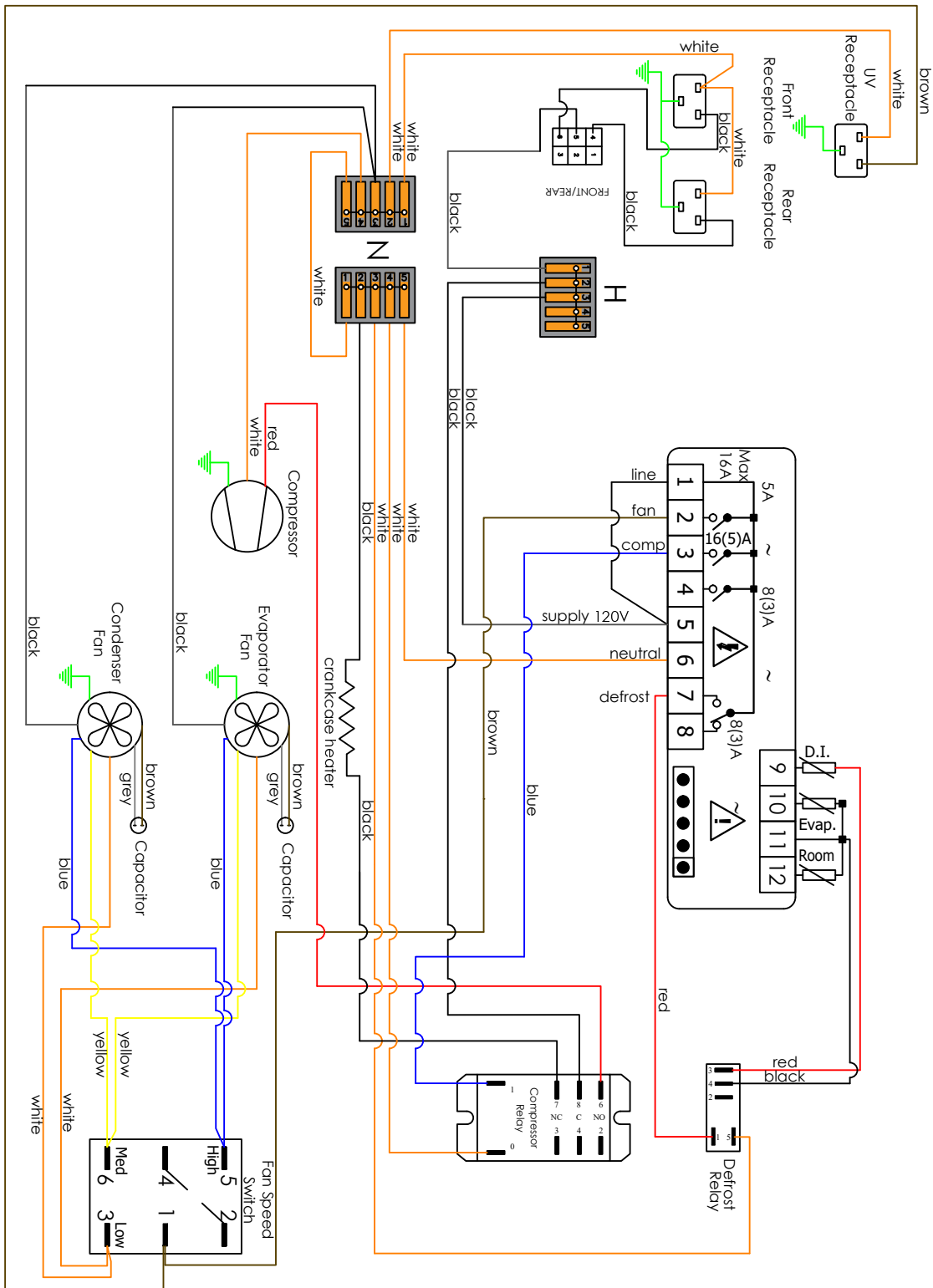

TROUBLESHOOTING GUIDE

Unit has ice forming on the evaporator	
Possible cause	Solution
Evaporator coil is dirty	Clean the coil with a vacuum. If coil is very dirty, use a spray bottle with a small amount of liquid dish detergent or coil cleaner. Spray coil, let set for five minutes, then flush with fresh water.
There is something blocking the supply and/or return air	Remove blockage
The evaporator fan is not turning on	Call a service tech to troubleshoot
The unit has not gone through an Anti-Frost Cycle yet	Check the coil for surface ice. Melt with blow drier until coil is warm to the touch. Soak up water with a towel.
The unit continues to ice	Observe ice formation pattern. If only part way up the coil face, unit could be low on refrigerant. If all the way up, the coil may be dirty or airflow is blocked.
Unit does not run/power up	
Possible cause	Solution
Unit is not plugged in	Make sure the unit is plugged into an outlet
Power switch not on	Turn unit on by pressing the power button on the control
Line voltage is incorrect rating for unit	Check line voltage to make sure there is 110V-120V
Bottle at setpoint	Lower setpoint
Thermostat not calling for cooling	Lower setpoint
Power select switch in wrong position	See page 11 for correct switch position
Faulty thermostat or wiring	Call Customer Service at 1-800-343-9463
Cellar temperature is too warm	
Possible cause	Solution
The temperature of the room to which the unit exhausts exceeds 110°F	Intake temperature needs to drop below 110°F
The unit is undersized for the cellar	Order correct size unit
There is something blocking the supply and/or return air on evaporator or condenser side of the unit	Remove airflow obstruction
Unit is mounted too low in the cellar	Relocate unit so the distance from the ceiling and top of the unit or cold air supply duct is no more than 18"
One or more of the fans is not turning on	Call Customer Service at 1-800-343-9463
Compressor is not turning on	Call Customer Service at 1-800-343-9463
Compressor keeps cycling on overload	Make sure all fans are working and there is no airflow obstruction
Poor seal around door	Make sure there are no air gaps around the door. If door seal is damaged, replace it.
Setpoint too high	Lower the setpoint
Evaporator coil is frosted or iced up	Observe ice formation pattern. If only part way up the coil face, unit could be low on refrigerant. If so, call Customer Service at 1-800-343-9463.
System runs constantly	
Possible cause	Solution
Leaky door seal or poorly insulated cellar	Fix leaky door seal and insulate cellar in accordance with this manual (page 9)

Unit leaks water

Possible cause	Solution
Unit is level	System should have a two-degree (2°) pitch towards the exhaust side
Drain line clogged or kinked	Check drain line to make sure water can flow freely
Drain is clogged, preventing water from escaping	1. Disconnect exterior drain line and clear it out; run provided drain line brush through the drain port and into the interior drain line. 2. Open access door and, using a flashlight, check drain line for blockage; drop a pan tab into the drip tray to prevent further blockages.
Drain line does not have a downward slope	Fix drain line so there is a downward slope from the unit to the drain
Coil is iced, causing drip tray to freeze and water to overflow	Melt ice with blow drier; soak up with a towel

Unit runs but does not cool

Possible cause	Solution
Lack of airflow	Make sure fan is unobstructed and coil is clean
Compressor not running	Call Customer Service at 1-800-343-9463
Unit undersized	Call Customer Service at 1-800-343-9463
Compressor is overheating	Shut unit off for 1 hour to allow compressor to cool. Turn back on and check for cooler air to flow out. If compressor runs, check for and clean condenser coil as a possible cause of compressor overheating. If problem repeats, call Customer Service at 1-800-343-9463.

Evaporator fan runs but compressor does not

Possible cause	Solution
Running an Anti-Frost cycle	Check evaporator coil temperature
Compressor and/or starting components faulty	Call Customer Service at 1-800-343-9463
"Fan on" (FOn) setting has been increased, allowing fans to run after the compressor turns off	Lower the "fan on" (FOn) time
Compressor may have overheated	Shut unit off for 1 hour to allow compressor to cool. Turn back on and check for cooler air to flow out. If compressor runs, check for and clean condenser coil as a possible cause of compressor overheating. If problem repeats, call Customer Service at 1-800-343-9463.

Compressor runs but evaporator fan does not

Possible cause	Solution
Faulty fan motor	Call Customer Service at 1-800-343-9463
Faulty controller	Call Customer Service at 1-800-343-9463

Compressor short cycles

Possible cause	Solution
Evaporator blows on bottle probe	Move bottle probe to a more central location
Unit low on refrigerant charge	Call Customer Service at 1-800-343-9463
Condensing fan motor/capacitor faulty	Call Customer Service at 1-800-343-9463
Compressor and/or starting components faulty	Call Customer Service at 1-800-343-9463

Humidity in cellar too low

Possible cause	Solution
Not enough moisture	Install a humidifier or decorative fountain in the wine cellar

MAINTENANCE SCHEDULE

Monthly	<ol style="list-style-type: none"> 1. Check for unusual noise or vibration 2. Check drain line to see if it is above the waterline (when draining into a vessel)
Every Six Weeks	Using the supplied drain line brush, clean the interior drain line leading from the drip tray and drop a pan tab into the drip tray (see illustration below for more details).
Annually	<ol style="list-style-type: none"> 1. Use a vacuum with brush attachment to clean coils; be careful not to crush coil fins 2. Inspect for corrosion 3. Check wiring connections and integrity of cords 4. Pour a 50/50 bleach solution into the external drain line every spring

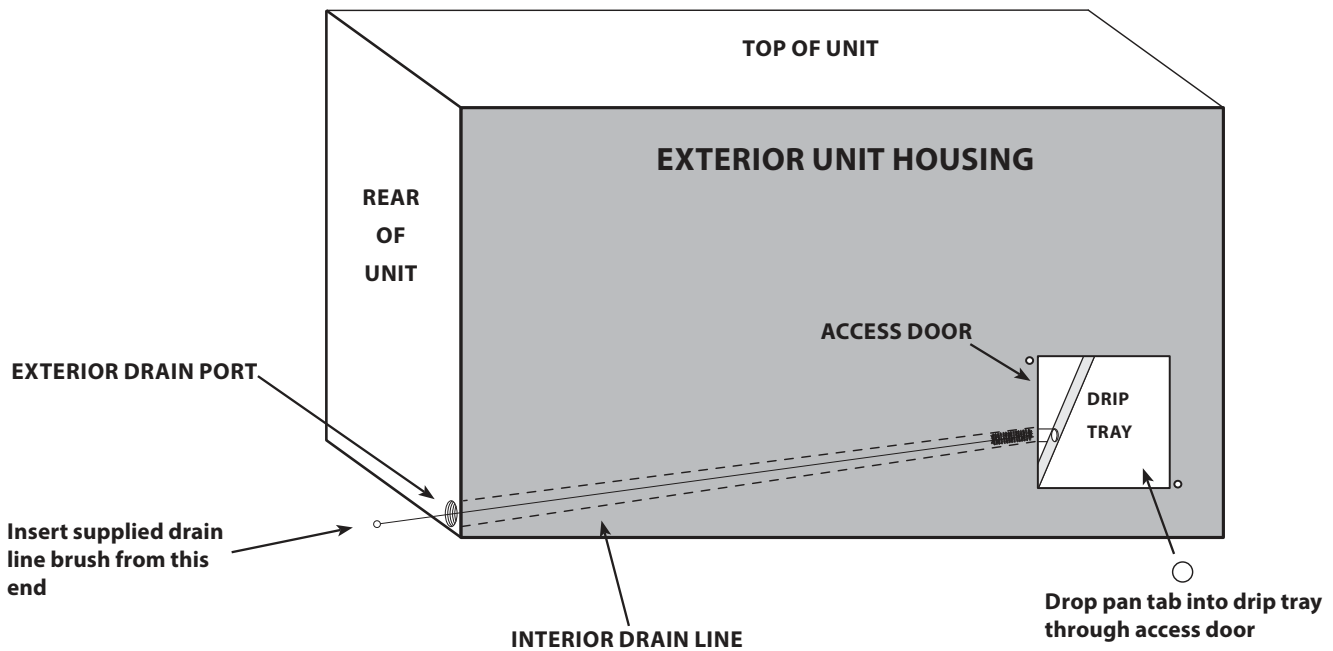

Pan tabs kill bacteria and related odors, remove sludge and scale, and help to prevent water damage caused by condensate overflow. They are non-corrosive and easy to install. Simply use the access door to drop a pan tab into the drip tray every six weeks.

WARNING: Keep pan tabs out of reach of children. They contain quaternary ammonium chloride and can cause skin and eye irritation. They are harmful or fatal if ingested. Wear protective gloves when handling pan tabs. Wash hands thoroughly after handling. If pan tabs make contact with eyes, rinse cautiously with water for several minutes. In case of an emergency, call 1-800-255-3924 (24 hours).

TECHNICAL ASSISTANCE

WhisperKOOL Customer Service is available Monday through Friday from 6:00 a.m. to 4:00 p.m. Pacific Standard Time.

The appointed customer service representative will be able to assist you with your questions and warranty information more effectively if you provide them with the following:

- The model and serial number of your WhisperKOOL system(s).
- Location of unit and installation details, such as ventilation, ducting, construction of your wine cellar, and room size.
- Photos of the cellar and installation location may be needed.

Contact WhisperKOOL Customer Service

1738 E. Alpine Ave
Stockton, CA, 95205
www.whisperkool.com

Email: support@whisperkool.com

Phone: 209-466-9463

US Toll Free: 1-800-343-9463

Fax: 209-466-4606

ACCESSORIES FOR COOLING UNITS

WhisperKOOL offers accessories to enhance and customize your wine cooling unit.

Exterior Grille

Protects the unit from the weather elements when placed on the exhaust side.

- Small Exterior Grille (used for Extreme 3500ti & 5000ti)
- Large Exterior Grille (used for Extreme 8000ti)

Condensate Pump Kit

The condensate pump kit is designed as an automatic condensate removal pump for water dripping out of our cooling units' drain line. The pump is controlled by a float/switch mechanism that turns the pump on when approximately 2¼" of water collects in the tank, and automatically switches off when the tank drains to approximately 1¼". The condensate pump kit allows the excess condensate to be pumped up to 20 feet away from the unit.

Extreme Ducting Kit

This kit allows either side of the unit to be ducted. Duct the cold air through a vent into the cellar, duct the hot exhaust air out of the home. This option allows for total installation flexibility.

Note: Flex or rigid ductwork is not included.

Accessories can be purchased at www.whisperkool.com

**WhisperKOOL Product Terms and Conditions
Including Product Limited Warranty And Product Installation Requirements
For WhisperKOOL Fully-Ducted Self Contained & Self Contained Units**

ATTENTION: PLEASE READ THESE TERMS OF USE CAREFULLY BEFORE INSTALLING YOUR WHISPERKOOL COOLING SYSTEM. INSTALLING YOUR WHISPERKOOL COOLING SYSTEM INDICATES THAT YOU ACCEPT AND AGREE TO EACH OF THE TERMS AND CONDITIONS SET FORTH HEREIN ("TERMS OF USE"). IF YOU DO NOT ACCEPT THESE TERMS OF USE, YOU RISK VOIDING YOUR WARRANTY AND ASSUMING ADDITIONAL REPAIR AND REPLACEMENT COSTS.

1. Purchase of a WhisperKOOL Cooling System assumes that the Purchaser ("End User") fully accepts and agrees to the Terms and Conditions set forth in this document. The Terms and Conditions of Sale and Owner's Manual are shipped with each unit and, if another copy is needed, replacement copies can be downloaded from the company website (whisperkool.com) or by contacting WhisperKOOL directly for a new copy. WhisperKOOL reserves the right, in its sole discretion, to change its Terms and Conditions at any time, for any reason, without notice.

2. WhisperKOOL Product Limited Warranty:

- A. Two (2) Year Limited Warranty. For the period of TWO (2) YEARS (the "Limited Warranty Period") from the date of original sale of a Product by WhisperKOOL and up to an additional (6) month grace period, if a WhisperKOOL Self-Contained Product is found to be defective in material or work-manship after undergoing WhisperKOOL's customer service troubleshooting, then, subject to the WhisperKOOL Product Limited Warranty Limitations and Exclusions as well as the other Terms and Conditions stated herein, WhisperKOOL will replace the Product with an authorized factory replacement under the terms of our Replacement Agreement. The Replacement Agreement outlines the terms, procedures, and additional considerations should the End User request a replacement for a cooling unit that is found to fall under warranty. For more information on our Replacement Agreement, visit www.whisperkool.com/warranty-information.
- B. Five (5) Year Compressor Limited Warranty. WhisperKOOL Products' compressor only will be covered for five (5) years from date of purchase. Labor and freight of the compressor is the End Users responsibility.
- C. Product Warranty Limitations and Exclusions.
 - 1. This limited warranty does not cover cosmetic damage caused during installation, damage due to acts of God, commercial use, accident, misuse, abuse, negligence, or modification to any part of the Product. Delivery and installation of the Product, any additional parts required, as well as removal of the Product if warranty work is required, are all at the sole cost, risk and obligation of the End User.
 - 2. This limited warranty does not cover damage due to improper installation or operation or lack of proper maintenance of the Product, connection of the Product to improper voltage supply, or attempted repair of the Product by anyone other than a technician approved by WhisperKOOL to service the Product.
 - 3. This limited warranty does not cover any Product sold "AS IS" or "WITH ALL FAULTS."
 - 4. Product that has been replaced during warranty period does not extend the warranty period past the original date of purchase.
 - 5. (5) This limited warranty is valid only in the continental United States. Sales elsewhere are excluded from this warranty.
 - 6. Proof of purchase of the Product in the form of a bill of sale, receipted invoice or serial number, which is evidence that the Product is within the Limited Warranty Period, must be presented by the End User to WhisperKOOL in order to obtain limited warranty service.

7. This limited warranty is void if the factory applied serial number has been altered or removed from the Product.
8. This limited warranty is voided if installed in an enclosure of insufficient design that does not follow the Product installation requirements stated herein and in the owner's manual.
9. Removing the rivets from the Product's unit housing without prior authorization from WhisperKOOL voids this limited warranty.
10. The End User must first contact WhisperKOOL Customer Service by telephone (at 1-800-343-9463) prior to attempting service on any Product still under the limited warranty; else the limited warranty is voided.
11. This limited warranty does not cover Product being concealed by, but not limited to, vegetation, fabric, shelving, mud, snow, or dirt. Product must not be painted or limited warranty will be void.
12. This limited warranty does not cover exposure to corroding environments such as, but not limited to, petroleum and gasoline products, cleaning solvents, caustic pool chemicals, and marine air.
13. This limited warranty does not cover any cause not relating to Product defect.
14. THE REPAIR OR REPLACEMENT OF THE PRODUCT AS PROVIDED UNDER THIS LIMITED WARRANTY IS THE EXCLUSIVE REMEDY OF YOU, THE END USER, AS WELL AS ANYONE ELSE IN THE CHAIN OF TITLE OF THE PRODUCT, DOES NOT START A NEW LIMITED WARRANTY TIME PERIOD, AND IS IN LIEU OF ALL OTHER WARRANTIES (EXPRESS OR IMPLIED) WITH REGARD TO THE PRODUCT. IN NO EVENT SHALL WHISPERKOOL BE LIABLE FOR INCIDENTAL, CONSEQUENTIAL, SPECIAL OR CONTINGENT DAMAGES FOR BREACH OF ANY EXPRESS OR IMPLIED WARRANTY ON THIS PRODUCT. THE IMPLIED WARRANTIES OF MERCHANTABILITY AND FITNESS FOR A PARTICULAR PURPOSE ARE HEREBY EXPRESSLY DISCLAIMED. Some states do not allow the exclusion or limitation of incidental or consequential damages, or allow limitations on how long an implied warranty lasts, so the above limitations or exclusions may not apply to you. This limited warranty gives you specific legal rights, and you may have other rights, which vary from state to state.
15. Failure of the End User to comply with all of the Product Installation Requirements, Maintenance Requirements and End User Requirements may, at WhisperKOOL's sole discretion, void this limited warranty.
16. No one has any authority to add to or vary the limited warranty on this Product.

3. Product Installation Requirements:

- A. Prior to installing a WhisperKOOL Product, the End User must read the WhisperKOOL Owner's Manual and thereafter the End User must follow the required installation, use and maintenance procedures set forth by WhisperKOOL in WhisperKOOL's Owner's Manual. The Owner's Manual is shipped with each Product and if another copy is needed, replacement copies can be downloaded from WhisperKOOL's website (www.whisperkool.com) or by contacting WhisperKOOL directly for a new copy of the Owner's Manual.
- B. It is highly recommended that the End User obtain the assistance of a wine storage professional.
- C. Failing to address all of the variables associated with proper installation will cause the Product to operate incorrectly and limit both the Product's ability to cool and the longevity of the Product itself.
- D. The End User is responsible for all risks and costs of installation of the Product, including but not limited to all labor costs as well as cost of any additional parts required for the proper and complete installation of the Product. The End User is responsible for all risks and costs of removing the Product if limited warranty work is required.
- E. The Product cannot operate at its optimum capacity if airflow is constricted by ducting or venting the exhaust side of the Product into a location with inadequate ventilation.

4. Maintenance Requirements

It is the End User's responsibility to clean off any accumulated dust, lint, or other debris from the front and rear intake grills; failure to do this on a regular basis will restrict the airflow and may affect the Product's ability to function properly. Periodically cleaning the Product's vents will help assure maximum cooling efficiency. The drain tube must also be checked and kept clean and free of debris and mold to maintain proper performance.

Mold is a natural living organism in the environment. It exists in the air in the form of microscopic spores that move in and out of buildings through doors, windows, vents, HVAC systems and anywhere else that air enters. Once it is discovered, mold must be addressed quickly and appropriately. Delayed or improper treatment of mold issues can

result in costly and reoccurring repairs. If the End User suspects a mold problem, it is always best to hire a qualified and experienced mold remediation specialist.

5. Additional End User Costs And Responsibilities

The following items are not covered under any warranty and are the sole responsibility of the End User:

- A. End Users should satisfy themselves that the Product they are purchasing is suitable for their particular needs and requirements, and thus no responsibility will be placed with WhisperKOOL for the End User's decisions in this regard.
- B. It is the End User's responsibility to secure safe haven/storage for ANY AND ALL items that are being kept and stored in the End User's wine cellar, including any Product. WhisperKOOL takes no responsibility for the safety and preservation of the aforementioned items in the event that the environment becomes unsuitable to maintain a proper storage environment.
- C. End User is responsible for initial installation costs, including, but not limited to, labor costs and the cost of any additional parts necessary to complete the installation.
- D. End User is responsible for all costs incurred for the installation and/or removal of the Product, or any part thereof, unless such cost has been agreed by WhisperKOOL to be a warranty repair prior to the work being performed.

6. Sales and Use Tax

WhisperKOOL only collects California sales tax for orders shipped within the State of California; WhisperKOOL does not collect sales tax for orders shipped to other states. However, the Purchaser and the End User may be liable to the taxing authority in their state for sales tax and/or use tax on the Product. The Purchaser and the End User should each check with their state's taxing authority for sales and use tax regulations.

7. Customer Service and Troubleshooting

WhisperKOOL's customer service department is available to answer any questions or inquiries for End Users regarding a WhisperKOOL Product, as well as to assist in performing basic troubleshooting, Monday through Friday, from 6:30 a.m. to 4:00 p.m. PST, at telephone number 1-800-343-9463. WhisperKOOL Corporation is located at 1738 East Alpine Avenue, Stockton, California 95205.

8. Miscellaneous Terms and Conditions

- A. Return Policy. All return inquiries must be made within thirty (30) calendar days of the original purchase of a Product and are subject to a twenty five percent (25%) restocking fee. Shipping costs are not refundable and the Purchaser is responsible for all return shipping costs (including customs fees and duties, if applicable).
- B. Security Interest. WhisperKOOL retains a security interest in each Product until payment in full.
- C. Construction and Severability. Every provision of these Terms and Conditions shall be construed, to the extent possible, so as to be valid and enforceable. If any provision of these Terms and Conditions is held by a court of competent jurisdiction to be invalid, illegal or otherwise unenforceable, such provision will, to the extent so held, be deemed severed from the contract of sale between Purchaser and WhisperKOOL, and all of the other non-severed provisions will remain in full force and effect.
- D. Governing Law/Choice of Forum. The laws of the State of California (without regard for conflicts of law) shall govern the construction and enforcement of the these Terms and Conditions of Sale (Sections 1 through 9 inclusive, including Product Limited Warranty And Product Installation Requirements), and further these Terms and Conditions of Sale shall be interpreted as though drafted jointly by WhisperKOOL and Purchaser. Any dispute will be resolved by the courts in and for the County of San Joaquin, State of California, and all parties, WhisperKOOL, Purchaser and End User, hereby irrevocably submit to the personal jurisdiction of such courts for that purpose. No waiver by WhisperKOOL of any breach or default of the contract of sale (including these Terms and Conditions of Sale) concerning a Product will be deemed to be a waiver of any preceding or subsequent breach or default.
- E. Correction of Errors and Inaccuracies. These Terms and Conditions may contain typographical errors or other errors or inaccuracies. WhisperKOOL reserves the right to correct any errors, inaccuracies or omissions, and to change or update these Terms and Conditions, at any time without prior notice.

9. Questions, Additional Information And Technical Assistance

A. Questions. If you have any questions regarding these Terms and Conditions or wish to obtain additional information, contact us via phone at 1-800-343-9463 or please send a letter via U.S. Mail to:

Customer Service
WhisperKOOL Corporation
1738 E Alpine Ave
Stockton, CA 95205

Email: support@whisperkool.com

Web: www.whisperkool.com

B. Technical Assistance. WhisperKOOL Customer Service is available Monday through Friday from 6:30 a.m. to 4:00 p.m. PST. The Customer Service representative will be able to assist you with your questions and warranty information more effectively if you provide them with the following:

1. The model and serial number of your WhisperKOOL UNIT.
2. The location of the system and installation details, such as ventilation, construction of your wine cellar, and room size.

Replacement Agreement

WhisperKOOL will replace the item(s) with the same or compatible item(s) for products that fail within warranty. Before initiating a warranty claim, the customer must complete all troubleshooting steps and the warranty claim process with a customer service representative.

Terms and Conditions

1. The customer will be charged a deposit to replace and ship the item via standard ground shipping under warranty. The total deposit amount will depend on the item being replaced. The customer is responsible for all shipping costs to and from the facility and any cost associated with the removal or reinstall of the product.
2. For Unit Replacements:
 - a. The cellar must be constructed per the guidelines in the Owner's Manual; an adequately built wine cellar must be fully insulated and include a completely sealed vapor barrier that will prevent excessive moisture from entering the wine cellar.
 - b. The cooling unit must be installed with no obstruction to the airflow. Adequate ventilation is required to dissipate heat away from the unit.
 - c. The condenser intake air temperature must not exceed the maximum recommended by WhisperKOOL.
 - d. The customer must install the external drain line to dispel the condensate.
 - e. **Warranty will be void if the unit is not installed, operated, maintained and serviced in accordance with instructions issued by WhisperKOOL, and a replacement will not be covered.**

Required Procedures

- An RMA (Return Merchandise Authorization) number will be issued at the time of the order.
 - Once the replacement item has been received and installed, use the new packaging to re-pack the original item and ship it back to the factory.
 - The customer is responsible for the return shipping of the item.
 - We recommend that you insure your shipment to cover any potential losses or damages that may occur during the shipping process.
 - Please fill out the credit card information below to complete the Replacement Agreement. **Providing a major credit card is a requirement of completing this agreement.**
 - Your credit card will be pre-authorized for the total deposit and charged when the replacement order is shipped and invoiced.
- **If you fail to return the original WhisperKOOL unit or part to the factory within 30 days, or no problem is found with the product, you will not be eligible for a refund.**
- All orders covered by warranty will receive a partial or full refund after evaluation has been completed and the claim has been verified, excluding items not covered under warranty, additional fees associated with the claim, and any expedited shipping charges associated with the order.

Additional Considerations

- This program is only for existing WhisperKOOL units under warranty.
- Replacement units are subject to availability. Your size replacement may not be available at all times.
- Refurbished cooling units may also have minor cosmetic imperfections.
- Factory-Authorized Replacements have been tested and are in proper operating condition at the time of shipment.
- The customer's responsibility is to secure haven/storage for ANY AND ALL items kept and stored in their wine cellar. WhisperKOOL takes no responsibility for the safety and preservation of the items mentioned above if the environment becomes unsuitable to maintain a proper storage environment.
- If you have any questions or require further assistance, please contact our Customer Service Department at 1-(800) 343.9463 or email at support@whisperkool.com.

*Whisper***KOOL™**

WhisperKOOL
1738 E. Alpine Ave
Stockton, CA 95205
www.whisperkool.com