

Wine Zone Ductless Split System

- Requires an HVAC technician to install and charge unit
- For use with R-134a refrigerant
- Electric connections for evaporator are hard wired to the condenser
- Industrial grade for longer life
- Indoor and outdoor condensing units available
- Field supplied drain line, refrigerant, and electric connections required

Supplies and Materials Needed for Installation

1. Condenser pad
2. Required electrical services
 - A. Dedicated service for condenser
 - B. 5-conductor low voltage wire from thermostat to condenser control panel
3. R-134a refrigerant for system
4. Miscellaneous hardware, brackets, sealant, reducers, etc...
5. An accurate digital probe style thermometer
6. Tools and equipment needed to perform the installation
7. The entire line set if none was purchased with the unit.
8. Additional line set beyond 50 feet if line set was purchased with the unit. See Table 1 on page 4 for proper line set sizes longer than 50 equivalent feet. Copper reducers and other fittings.

Supplies and Materials Furnished with Equipment

1. Condenser with pre-wired control panel
2. Pre-assembled outdoor upgrade kit, if ordered
3. Wall mounted evaporator modified for system
4. Thermostat
5. 50 ft. of 1/4 x 3/8" line set (if ordered with unit)
6. Filter drier, may be factory installed
7. Sight glass, may be factory installed
8. Fan cycle control, mounted and wired.
9. Wiring diagrams
10. Installation instructions with copy of Diagnostic Sheet
11. Warranty information with copy of Diagnostic Sheet

A **qualified service technician** must record all of the information on the diagnostic sheet **before** calling for technical assistance. The technician **must** be able to identify the unit with the order number and serial numbers to receive accurate trouble shooting assistance. All recommendations for repair or adjustment will be based on the information provided by the **service technician**. Any incorrect recommendations based on incorrect or insufficient data are not covered by the warranty.

Installation Instructions

Caution: A qualified technician must install this refrigeration equipment. Please read, understand, and follow all instructions in this manual prior to start up. Failure to install and adjust this refrigeration unit in compliance with these instructions will void the warranty.

A temperature pressure chart for R-134a can be found on page 26.

1. Select a suitable location for the evaporator with respect to air circulation, drain, refrigerant and electrical lines. Adequate air circulation requires a 36" clearance in front of the unit, **do not** place any obstruction in front of the evaporator. Do not attempt to duct this evaporator. Before installing any unit, the installer must determine that the wall or ceiling can safely support the weight of the unit. Provide adequate clearance for maintenance. Check local codes for additional precautions. The face of the evaporator should be within 4" of the front of the racking, if placed in double deep racking you must bring the evaporator forward so it is within 4" of the front of the rack.
2. Place the condenser at the desired location outside the wine cellar in a well-ventilated area or outdoors. **Indoor condensers must be placed in a space of 1240 cubic feet or larger to prevent excessive condensing temperatures.** Check local codes for proper venting of mechanical rooms. Field supplied vibration absorbing mounting pads and insulated compressor jackets effectively reduce noise transmitted by the unit. Condenser face must be at least 12" from any obstruction and entering air must not exceed 110° F. When installing an outdoor condenser, be sure that it is located so that leaves or snow do not accumulate and block the airflow. This can be accomplished by setting the condenser on a concrete slab, blocks, etc. Place the unit so prevailing winds do not blow rain, snow and debris into the open ends of the outdoor cover. Avoid placing the outdoor condenser in direct sunlight, especially in warm climates. Condenser air directed toward or away from the dwelling may cause undesirable noise for owners and their neighbors. This must be considered when placing the unit outdoors.
3. Remove the nitrogen holding charge from the condensing unit. Open the suction side backseat valve and allow the nitrogen to flow out. Open the high side backseat valve. The Schrader core in the access tee must be depressed to release the nitrogen. Connect a refrigerant hose with a Schrader depressor and allow the nitrogen holding charge to flow out of the open hose. The high side back seat valve must remain open 1/2 to 1 turn during evacuation and during normal use to allow the condenser fan motor speed control to transducer to sense the head pressure.

Using a silver/phosphorus/copper alloy with at least 15% silver content, braze the refrigerant line set to the condenser connections with nitrogen flowing through the lines to eliminate carbon deposit build up on the inside of the joints that will contaminate the refrigerant and restrict the drier and thermostatic expansion valve. **Do not** sand nickel plated valves prior to brazing. Use brazing flux on all fittings with a nickel finish. **Do not** overheat the backseat valves when brazing. **Thoroughly** heat the pipe (it should glow red) **before** applying heat to the valve fitting. For back seat valves with two access ports, the port furthest from the valve stem will never close; leave it securely capped off.

Remove the flare caps from the evaporator line set connections to remove the nitrogen holding charge. Connect the line set to the evaporator using the flare connections. **Do not** remove the flare connections and braze the line set to the evaporator connections.

You **must** install the line set according to **Table 1** on the following page. Failure to do so voids the warranty. The evaporator and/or condensing unit may have different fitting sizes than the line set, so field supplied reducers are necessary. Run the line set according to Table 1, and reduce at the condenser and evaporator connections. Field supplied copper reducers and other fittings will be required.

Maximum line length is 200 equivalent feet. Long sweep elbows and any bends in soft copper are equivalent to 5 linear feet. Line lengths in excess of 200 equivalent feet may cause compressor damage and will void the warranty. Example: To determine the equivalent length of the line set add up the linear feet of suction line. Multiply the number of elbows required and add it to the total length of suction line.

Example:

Horizontal pipe	40 linear ft.
Vertical pipe	10 linear feet
<u>8 elbows x 5</u>	<u>40 equivalent feet</u>
Total equivalent feet	90 equivalent feet

Following Table 1 and guidelines for vertical risers below, the correct line set size is 1/4" liquid line and 1/2" suction line. The 10 linear feet of vertical suction line is 3/8."

Proper piping practices must be followed. The line set must be securely fastened to the building structure for its entire length. The suction line must be insulated the entire length of the run. Horizontal line runs must slope 1/2" per 10' towards the condenser for proper oil return. No dips, sags or other low spots that will trap refrigerant oil are permitted. This prevents starving and slugging the compressor with oil. We highly recommend using rigid copper for this reason.

For systems with condensers 10 feet or more above the evaporator, reduce the suction line size by one. For example, 5/8" line changes to 1/2" and 3/4" changes to 5/8" for the **vertical** section of the line only. Do not install a suction line riser of less than 3/8" diameter. Install a P trap at the bottom of the riser of the same size as the horizontal piping.

Line sets up to 70 equivalent feet will use 1/4" liquid line and 3/8" suction line.
 Line sets 71 to 150 equivalent feet will use 1/4" liquid line and 1/2" suction line.
 Line sets 151 to 200 equivalent feet will use 1/4" liquid line and 5/8" suction line.

Line sets longer than 200 equivalent feet will void the warranty. Minimum line set length is 15 linear feet.

Table 1

Unit	0'-70' Equivalent feet Line set	71'-150' Equivalent feet Line set	151'-200' Equivalent feet Line set
WZDS2400a	1/4" x 3/8"	1/4" x 1/2"	1/4" x 5/8"

Minimum linear line set length is 15'

Line set sizes may differ from system component fitting sizes so field supplied reducers are necessary. Run the line set according to Table 1, and reduce at the condenser or evaporator if necessary.

For outdoor units, cut or drill a hole through the most convenient stationary side of the condenser cover large enough for the line set to easily pass through. Cut the hole above the height of the compressor. Do not run the line set through the bottom of the unit or the air grilles at either end. Do not run the line set through a panel that moves when the lid is opened.

Sample Piping Configurations

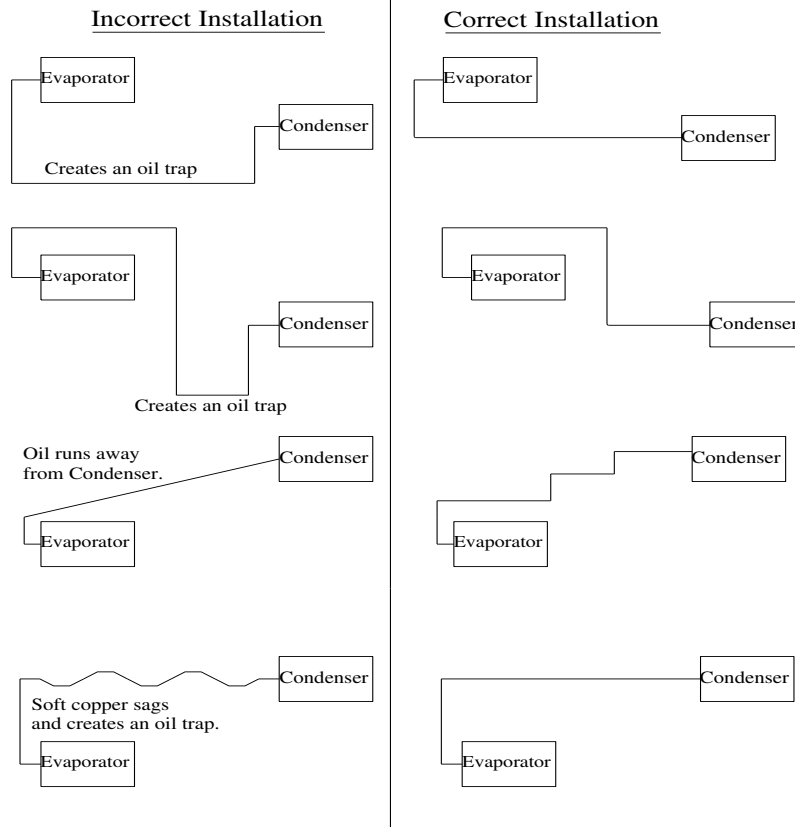

Rule of thumb: Once the suction line leaves the evaporator and turns downward, it cannot turn and go back up to get to the condenser, at any point. The only time a trap in the suction line is acceptable is at the bottom of a 10' or taller riser.

4. Install the filter dryer and sight glass, if not already factory installed. Wrap with a wet rag to prevent over heating during brazing.
5. Perform leak test with dry nitrogen, but **never** expose the system to leak test pressures greater than 150 PSI. **Test all fittings including factory installed flare fittings on condenser and evaporator that may have loosened during shipping.** Leaks on unit(s) from a result of loose valves, interconnecting fittings, and/or field piping are not covered by the warranty. It is the installer's responsibility to locate and repair all leaks prior to start up.
6. Evacuate the system below 1000 microns for 1 hour, and the moisture indicator shows "Dry."
7. Install electrical wiring according to the Electrical Requirements on page 13 and the appropriate wiring diagram. Follow all applicable codes.
8. After isolating the vacuum pump from the system, break the vacuum to a positive pressure using refrigerant connected to the liquid line. Add approximately 20 psi of refrigerant **vapor**. **Do not start unit for the first time with a full charge.** Adding more refrigerant prior to start up will damage the compressor.

9. **Apply power to units for 24 hours prior to start up to allow crankcase heater to warm the compressor and then start the unit.** Complete the charging process with the compressor running and add the balance of the charge into the suction line of the system. Liquid refrigerant should never enter the compressor directly. Use a metering device to prevent slugging when charging with liquid.
10. The ICM333 Head Pressure Control is factory set to maintain approximately 140 psi head pressure. Verify the head pressure remains at 140 psi or above. See page 22 and the charging table on page 23 for instructions on how to adjust the fan speed controller. The high side backseat valve must remain open during normal use for the condenser motor fan speed control transducer to sense the head pressure **Never** adjust the pressure control to bring on the condenser fan motor above 200 psi. Slowly add refrigerant until the bubbles in the sight glass disappear. The condenser fan motor must be running to complete the charge.
11. After the system has run for 10 minutes check the sight glass again. During normal operation with R-134a there should be no bubbles in the sight glass. If bubbles are present, the system is low on refrigerant. Add refrigerant to eliminate the bubbles. Charge the system to approximately 5° of sub-cooling. To calculate sub-cooling for R-134a subtract the liquid line temperature from the saturation temperature corresponding to the head pressure. Measure the liquid line temperature between the receiver and filter drier with an accurate, digital, thermocouple style thermometer.
12. Allow the wine room temperature to fall to 55°F. **Check the super heat.** Measure the suction pressure at compressor access port. From refrigerant pressure-temperature tables, determine the saturation temperature R-134a at the observed suction pressure. Measure the suction line temperature at the compressor. Subtract the saturation temperature from the measured suction line temperature. The difference is the superheat. Refer to the temperature pressure chart on page 26 in these instructions.

The superheat should be 8° to 18°F. If the superheat is not in this range, the thermostatic expansion valve must be adjusted. To adjust the expansion valve, remove the seal cap from the bottom of the valve. Turn the adjustment screw clockwise to increase superheat and counterclockwise to decrease superheat. **Caution: There are 10 turns on the adjustment stem. When stop is reached while turning the superheat adjustment stem, any further turning will damage the valve.** One complete 360° turn changes the superheat approximately 3°-4°F. As much as 30 minutes may be required for the system to stabilize after the adjustment is made. Replace and hand tighten the seal cap. Always replace the evaporator face plate between TXV adjustments.

13. Perform the final check of the refrigeration unit. The cellar temperature must be between 53° and 58° F. Check the sight glass and gauge readings again. The super heat must be 8°-18° F (see step 12). The hot gas line temperature must not exceed 225° F. Never exceed the maximum amp draw (RLA) for the compressor. Adjust the TXV, and charge as necessary. All measurements should be taken with the condenser fan motor running. All temperature readings should be taken with a digital probe style thermometer.
14. If the recommended system pressures and temperatures cannot be achieved, refer to the troubleshooting chart on pages 24 and 25.

Piping Diagram

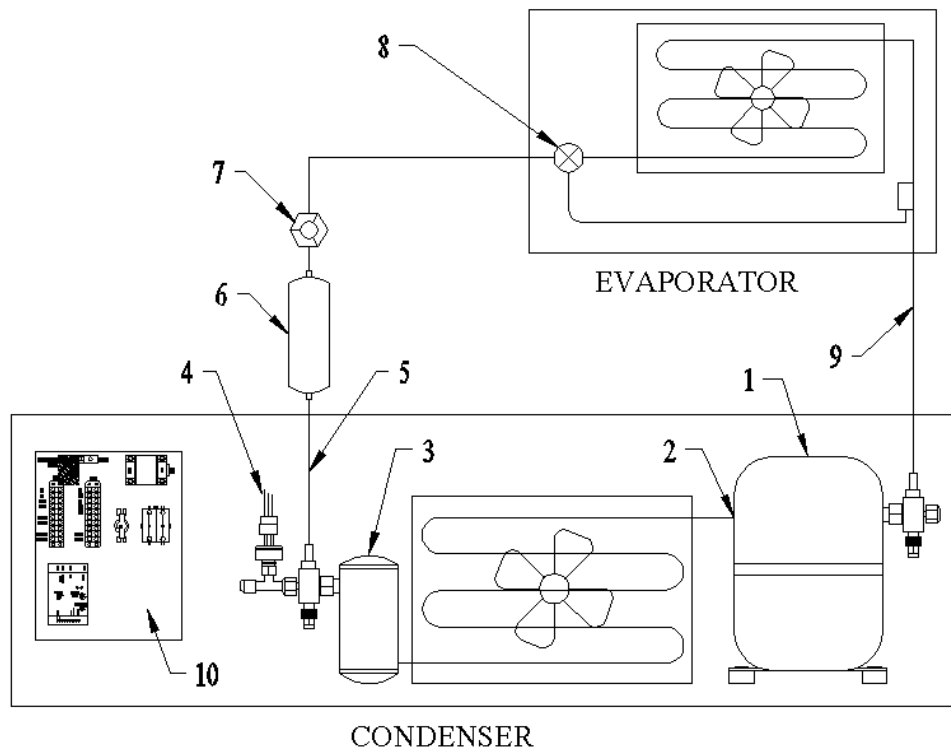

1. Compressor.
2. Discharge (hot gas) line. The vapor line between the compressor outlet and the condenser coil inlet. Measure the discharge (hot gas) line temperature here, approximately 12" from the compressor outlet. This temperature should never exceed 225 degrees.
3. Receiver. Measure the head pressure at the receiver service valve. This backseat valve must remain open 1/2 to 1 turn during normal use to allow the condenser fan motor speed control transducer to sense the head pressure. See step 3 on page 3 for brazing instructions.
4. ICM333 Head Pressure Control. See step #10 on page 6.
5. Liquid line. Measure the liquid line temperature here to determine sub-cooling.
6. Filter drier.
7. Sight glass.
8. Thermostatic expansion valve. See step 12 on page 6.
9. Suction line. Measure the suction pressure at the compressor suction service valve. Measure the suction line temperature near the compressor service valve. See step 3 on page 3 for brazing instructions.
10. Condenser control panel. Contains the system electrical components.

Installation of the Indoor Unit

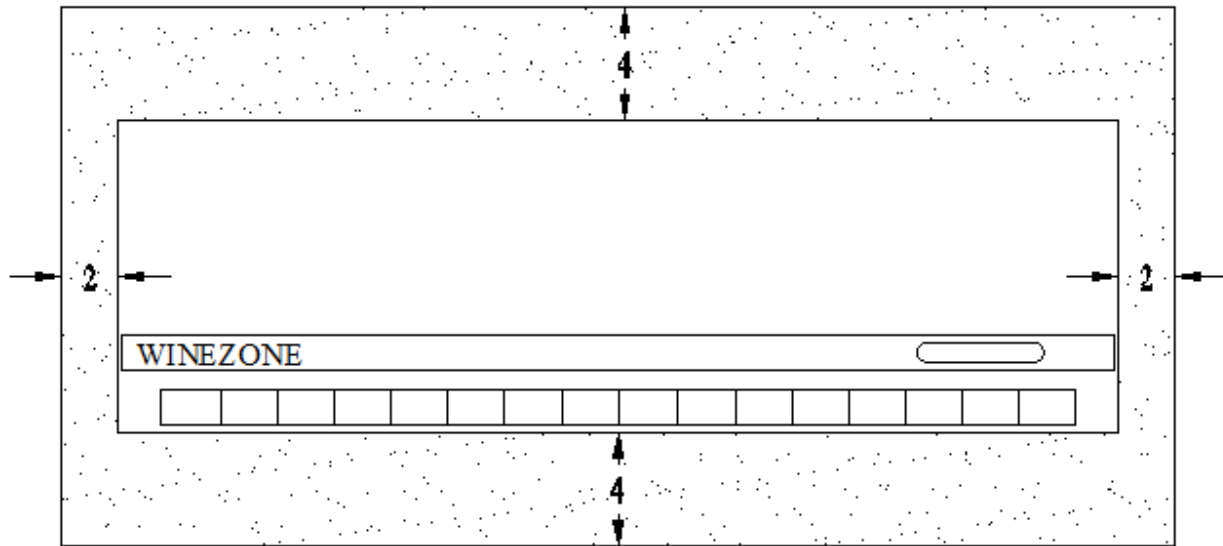

Firmly secure the evaporator mounting plate on a wall strong enough to withstand the weight of the unit. The plate must be level and allow for the clearances shown in the figure above. The evaporator must be installed in such a way as to prevent short cycling of the discharge air with the return air. **Adequate air circulation requires a 36" clearance in front of the unit; do not place any obstruction in front of the evaporator.** The face of the evaporator should be within 4" of the front of the racking, if placed in double deep racking you must bring the evaporator forward so it is within 4" of the front of the rack. Do not place the unit in direct sunlight, or above a door or window. Do not attempt to duct this evaporator. The location must also be suitable for refrigerant piping and condensate drainage. The evaporator discharge air must not blow on the thermostat.

The refrigerant piping can be routed to the unit in a number of ways. Number 2 in the diagram below indicates a cutout in the unit casing. Using the cutout will leave the refrigerant piping, condensate drain, and electric exposed in the cellar and should be avoided. Numbers 1 and 3 indicated below, are for piping routes that will leave the refrigerant lines, drain and electric concealed, and should be used for the most attractive installation. A single, 2¼" or 2 ½" hole will accommodate the passage of the line set, drain and electric through the wall. Slope the hole downward through the wall and fasten the drain line to the **bottom** of the line set for proper drainage. These hole locations are indicated on the mounting plate drawings as well. The refrigerant piping may be gently bent or twisted to use any of the indicated pipe routes. Field supplied reducers or other fittings will be required.

When the line set will be run on the inside of the wall before the drywall is hung, use the suggested route (route number 1). Route number 1 is the preferred route. Route 2 will leave the refrigerant piping, electric, and drain exposed. For installations where the line set will be accessible on the backside of the wall, the alternate route (route 3) can be used. **Use caution when using route 3. Secure the piping above the bend before turning the piping to use route 3 to prevent kinking the suction line.**

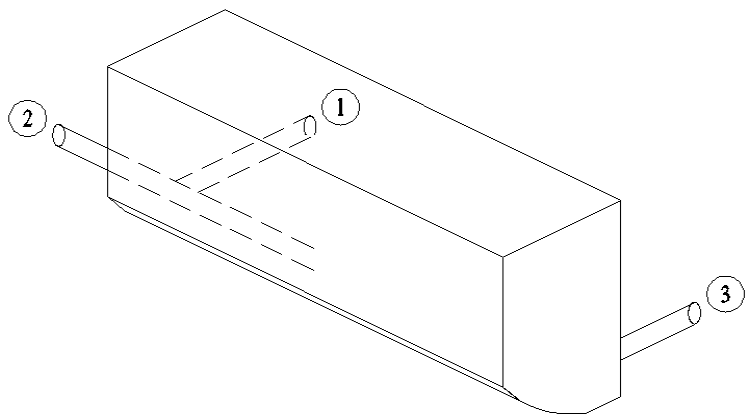

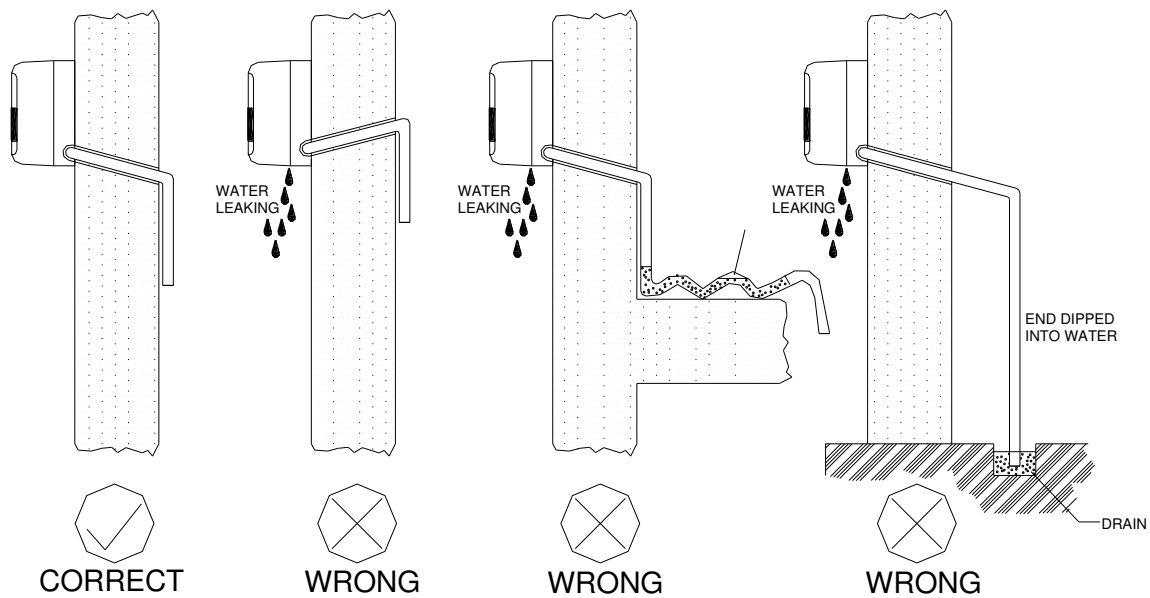

The indoor drainpipe must slope downward and have no traps. The drain must be fastened to the **bottom** of the refrigerant lines. The drain requires an air gap to flow properly. Place the two hooks at the rear top of the evaporator to hang the unit from the upper edge of the mounting plate. Ensure the hooks are properly seated on the mounting plate by sliding the unit to the left and right. Gently press on the bottom face of the evaporator to snap the bottom of the evaporator into place on the mounting plate.

The face of the evaporator casing can easily be removed. Screws are concealed under plastic covers on the bottom leading edge of the unit, under the air discharge louver. Remove the covers to expose the screw heads and remove the screws. Remove screws above the air discharge under the hinged filter cover. Pull out and lift the bottom of the evaporator casing to uncover the electric hook up.

After installation, properly seal the hole(s) where the refrigerant, drain and electric lines penetrate the wall or ceiling. Failure to do so may result in uncontrolled condensation and water damage.

Evaporator Electric

Securely fasten the ground wire to the terminal with the green or green and yellow striped wire. The other two wires on the **evaporator terminal block** receive 115 volts from terminals marked EVAP on TB1 in the condenser control panel. The fan motor wires with wire nuts on them are not used.

Mounting Plate for 2400a Evaporators

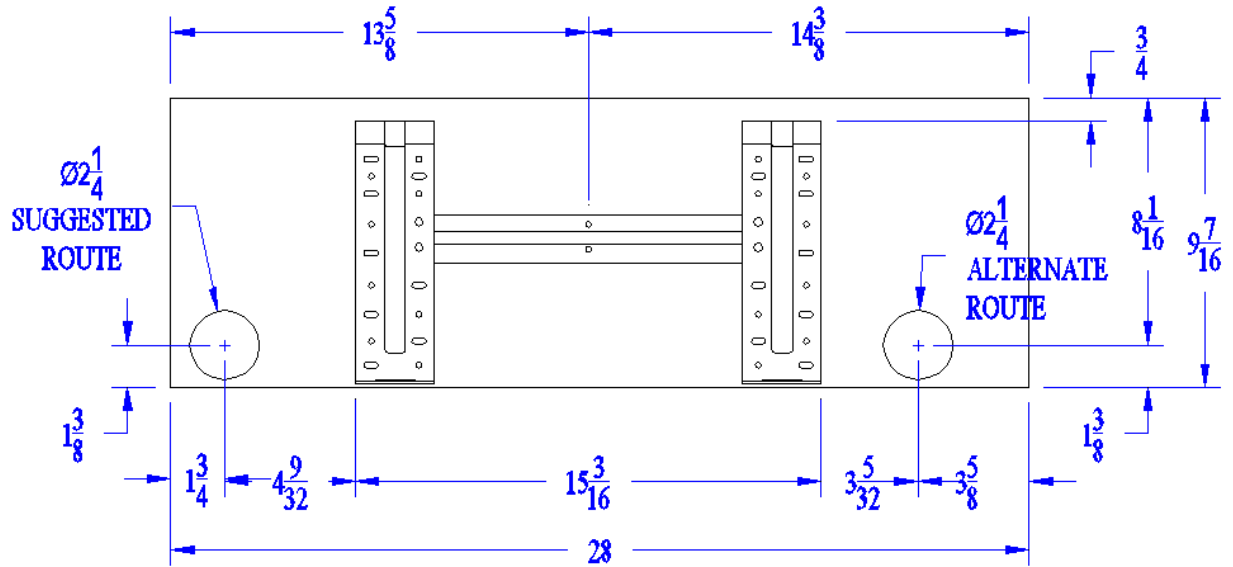

The holes shown are the best locations to route the refrigerant lines, condensate drain, and electric. For installations where the line set will be accessible on the backside of the wall, use the alternate route. When that is not possible, and the line set will be run inside the wall before the drywall is installed, use the suggested route. This will leave the flare connections exposed so they can be connected after the walls are finished.

Use caution when using the alternate route. Secure the piping above the bend before turning the piping to prevent kinking the suction line.

A **qualified service technician** must record all of the information on the diagnostic sheet **before** calling for technical assistance. The technician **must** be able to identify the unit with the order number and serial numbers to receive accurate trouble shooting assistance. All recommendations for repair or adjustment will be based on the information provided by the **service technician**. Any incorrect recommendations based on incorrect or insufficient data are not covered by the warranty.

Ductless Split Wall Mount Evaporator

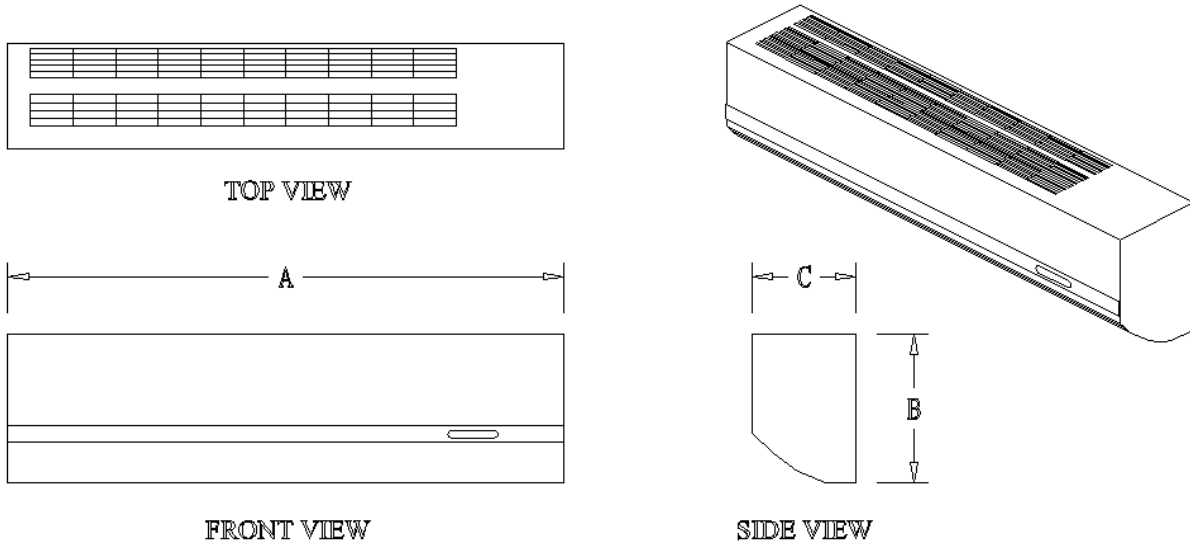

Specifications for Standard Ductless Split Evaporator

System	dB	Evaporator	Dimensions In Inches			Liquid Fitting	Suction Fitting	Drain Fitting	Power Supply	Weight
			A	B	C					
WZDS2400a	40	WB009	28	9 7/16	7 1/8	1/4 MF	3/8MF	5/8 Barbed	115/60/1	15 lbs.

You must install a line set according to Table 1 on page 4.

Field supplied reducers may be required. Reduce at the evaporator and condenser connections.

A minimum of 4" clearance required on top and bottom, 2" of clearance required on each side.

Use caution when using route 3, the alternate connection route. Secure the piping above the bend before turning the piping to prevent kinking the suction line.

Condenser Specifications

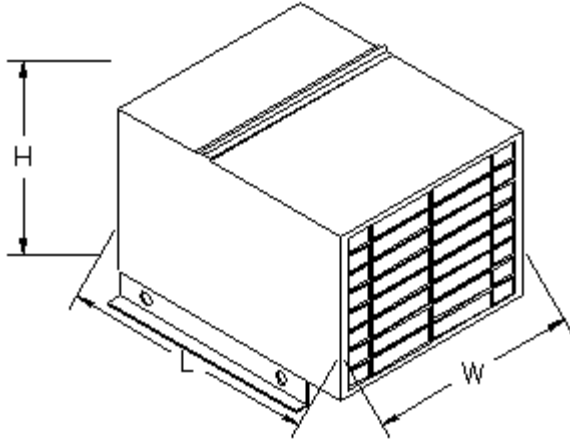

Outdoor Condenser

You must install a line set according to Table 1.

Field supplied reducers may be required. Reduce at the evaporator and condenser connections.

Minimum of 12” clearance required on each side of unit.
Minimum of 36” clearance required above unit.

For outdoor units, cut or drill a hole through the most convenient stationary side of the condenser cover large enough for the line set and electric to easily pass through.

Cut the hole above the height of the compressor. Do not run the line set or electric through the bottom of the unit or the air grilles at either end. Do not run the line set through a panel that moves when the lid is opened.

Model	dB	Length In inches	Width in inches	Height in inches	Liquid Line Fitting	Suction Line Fitting	Wt. In lbs	Power Supply	Min Circuit Amps	Max Fuse
WZDS2400a/OC	50	27	20	20	1/4 SW	3/8 SW	114	115/60/1	9.5	15

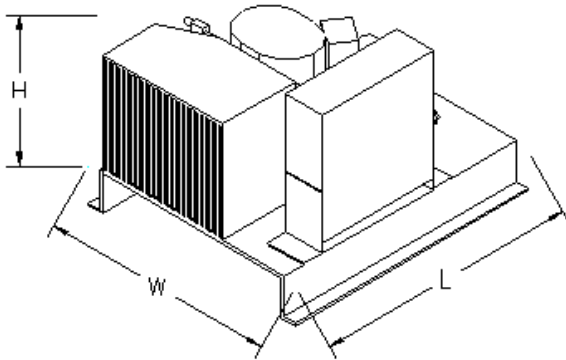

Indoor Condenser

You must install a line set according to Table 1.

Field supplied reducers may be required. Reduce at the evaporator and condenser connections.

Minimum of 12” clearance required on each side of unit.

Must be installed in a space of 1240 cubic feet or larger.

Model	dB	Length In inches	Width in inches	Height in inches	Liquid Line Fitting	Suction Line Fitting	Wt. In lbs	Power Supply	Min Circuit Amps	Max Fuse
WZDS2400a/IC	50	25	20	18.5	1/4 SW	1/2 SW	89	115/60/1	9.5	15

Field Wiring

Condensing unit Control Panel

Terminal Board One

Terminal L1 – *115 Line voltage for the condenser (See condenser specifications for proper fuse size)

Terminal N – *115 Neutral for the condenser (See condenser specifications for proper fuse size)

Terminal EVAP – Load voltage to the evaporator fan motor. Connect to terminal block in the evaporator

Terminal Board Two

Terminal R – Thermostat R

Terminal Y – Thermostat Y

Terminal C – Thermostat C

Terminal G – Thermostat G.

Terminal A – Thermostat A, used only with humidification

Terminal HUM – 24 volt humidifier

The System Ground Lug is located above the Terminal Boards

Electrical Requirements

1. Check the Copeland rating plate located on top of the condenser coil, for proper voltage, maximum fuse, run load amperage, and wire size.
2. Line voltage from service panel for cooling unit. The power circuit connects to terminals L1 and N on TB1 in the condenser control panel.
3. The evaporator circuit connects to terminals marked EVAP on TB1 in the condenser control panel.
4. Low voltage wire from the thermostat goes to the condenser control panel only. No low voltage connections are required at the evaporator. Low voltage control wiring runs from the thermostat to the condenser control panel.
5. All equipment must be installed according to the National Electric code and all local codes and ordinances.

Line Voltage

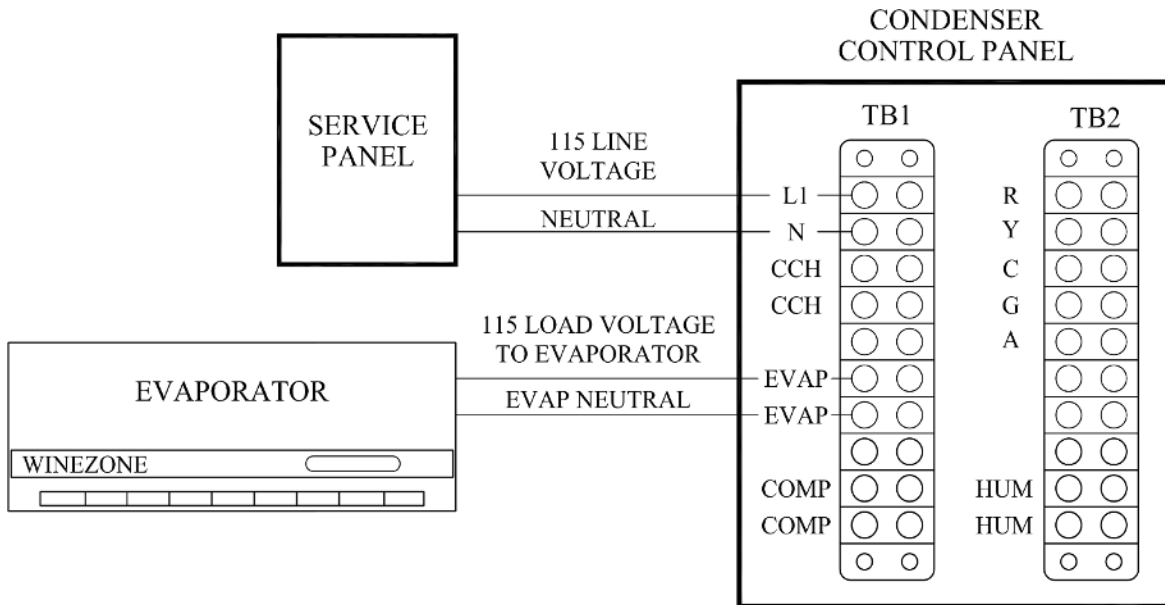

1. Run a 115-volt circuit from the service panel to terminals L1 and N on TB1 in the condenser control panel. Check the condenser rating plate or page 12 for the proper fuse size. Attach the ground wire to the lug in the upper left hand corner of the condenser control panel.
2. Load voltage for the ductless evaporator will come from terminals marked EVAP on TB1 in the condenser control panel. Connect these wires to the small **terminal block** with the evaporator fan motor wires attached. Attach the ground wire to the terminal with the green or green and yellow striped wire. Wires terminated with wire nuts are not used.
3. Each unit must be installed in accordance with the National Electric code. Check local codes for additional precautions and ordinances to installation.

Thermostat Installation Cooling Only

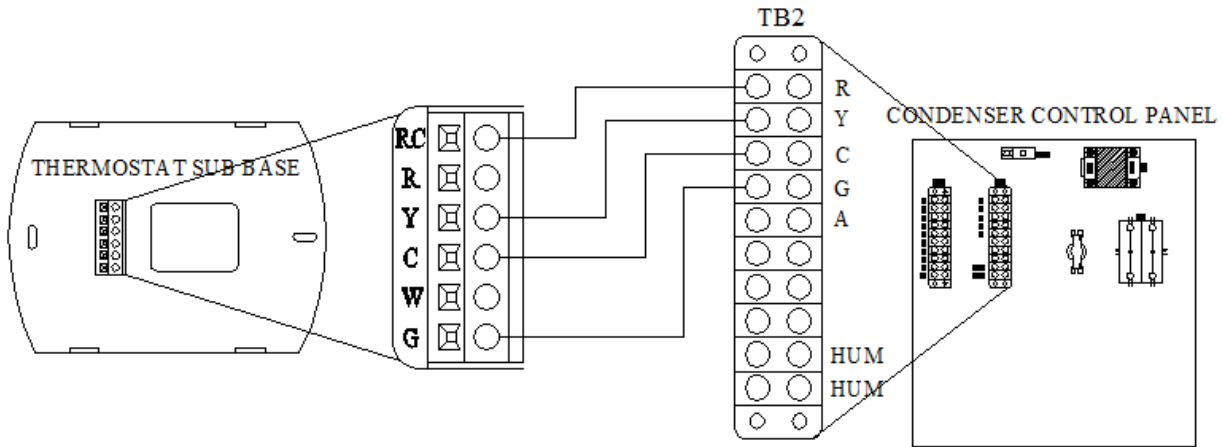

Mount the Honeywell FocusPRO5000 thermostat in the cellar approximately 5 feet above the floor in an area of good air circulation of average cellar temperature. Do not install it where it will be affected by the evaporator supply air, lighting, wall switches, concealed pipes or chimneys, or warm exterior walls, etc. The thermostat terminal RC connects to terminal R on TB2 in the condenser control panel. Thermostat terminal Y connects to terminal Y on TB2 in the condenser control panel. Thermostat terminal C connects to terminal C on TB2 in the condenser control panel. Thermostat terminal G connects to terminal G on TB2 in the condenser control panel. Use quality 18-gauge thermostat wire. Read and follow the manufacturer's installation instructions.

Conventional Terminal Letters	
RC	24 VAC power
Y	Cooling
C	24 VAC common
W	Not used
G	Fan
A	Not used

We recommend you enter the Installer Setup in the Honeywell Installation Guide and choose the following settings

- #1 System type to 4 for Cool only
- #9 Stage 1 compressor cycle rate to 3
- #14 Temperature display to 0 for Fahrenheit
- #15 Compressor protection to 5
- #28 Cool temperature range stop to 53°

Turn the system to cool and set the temperature to 55°.

Thermostat Installation for Cooling and Humidification

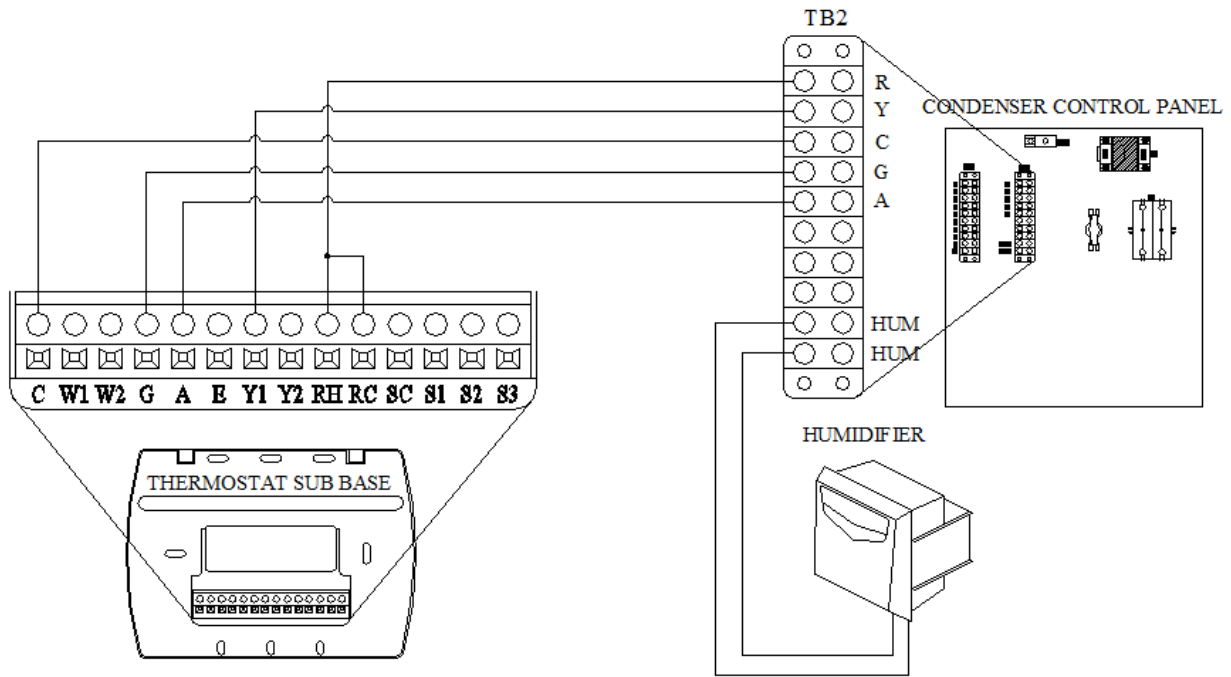

Thermostat Installation

Mount the WineZone thermostat in the cellar approximately 5 feet above the floor in an area of good air circulation of average cellar temperature. Do not install it where it will be affected by the evaporator supply air, lighting, wall switches, concealed pipes or chimneys, or warm exterior walls, sunlight, etc. Use quality 18-gauge thermostat wire. Read and follow the manufacturer's installation instructions. Carefully read and understand the instructions supplied with the thermostat before attempting to operate or install this thermostat. The following thermostat installation instructions are a summary of the install and set up for using this thermostat with a WineZone system. For detailed installation and troubleshooting instructions please refer to the manufacturer's instructions included with the thermostat.

Install the Wallplate

1. Position the wallplate on the wall with the directional arrow pointing up and the terminal blocks facing outward.
2. Pull equipment wires through the wallplate wiring passage.
3. Use a level to determine the best horizontal wallplate mounting position.
4. Mark positions of screw holes (two at minimum) with a pencil and remove wallplate.
5. Drill holes at pencil-marked locations (3/16" for drywall, 7/32" for plaster).
6. Insert the wall anchors in the holes, tapping them into place.
7. Mount the wallplate onto the wall and insert screws through the mounting holes. Assure that all loose wires come through the center opening of the wallplate.
8. Cap off any unused wire and terminate properly according to local building codes.

Attach Wires to Thermostat Wall plate

1. Select the terminal designations that correspond to the system type. Follow the table below:

Warning: Disconnect power before beginning installation.

Caution: Copper wire only. Insulate or wire-nut all unused leads.

Use care to avoid electrostatic discharge to thermostat.

Note 1: Do not connect wire to A if a humidifier is not installed.

Note 2: Do not connect wire to Y2 or W1 if a duct heater is not installed.

Conventional Terminal Letters	
C	Unswitched side, 24 VAC
W1	Not used
W2	Not used
G	Fan
A	Humidity
E	Not used
Y1	Stage 1 Cool
Y2	Not used
RH	Power for Heating Switched Side, 24 VAC
RC	Power for Cooling, Switched Side 24 VAC
SC	Sensor Common, if used
S1	Not used
S2	Not used
S3	Not used

2. Using a small flathead screwdriver, loosen the screws on the terminal blocks that correspond to the system type.
3. Strip the insulation of each wire at a proper length (about 1/4")
4. On the wallplate, insert wires into the terminal blocks that correspond to the system type, then re-tighten each screw for each terminal.

Note: Do not over-tighten or use excessive force.

5. Assure that no uninsulated wires are exposed: Cap off and place a wire nut on any unused wires. Assure that the attached wires fit into the cavity on the back of the thermostat.

Connect Power to the Thermostat Wallplate

Power Options

The T12000 Series thermostat will operate on 24 VAC power and/or two AA batteries (both are recommended). Using 24 VAC with AA battery backup is highly recommended.

Wiring 24 VAC Common

Single-Transformer system. Connect the common side of the transformer to the "C" screw terminal of the thermostat wallplate. Assure that the metal jumper connects "RC" and "RH." Connect power side to the RC/RH and assure that the jumper remains in place

Install Batteries and Remove Tab

1. Insert two AA batteries (included) into the back compartment of the thermostat.
2. Remove the plastic insulator tab from the back side of the thermostat. **IMPORTANT:** The insulator tab must be removed before setting the real-time clock.

Set the Clock, Month, Day

When power is first applied to the thermostat, it will activate the clock display. It is recommended that the time and day are entered before performing advanced configuration. On the touchscreen area, press the Clock key and use the up and down arrows to set the hour mode, clock hour, minutes, year, month, and numerical date. Press Done to finish.

Verify System Setting is Turned Off

1. Press any part of the touchscreen area to enter the Home Display.
2. Press System to enter system mode
3. Press System repeatedly until “Off” flashes, then press Done.
4. Press Fan key to enter fan mode.
5. Press Fan repeatedly until “Auto” flashes, then press Done.

Perform Advanced Configuration

Perform advanced configuration before attaching the thermostat to the wallplate. Advanced configuration is done by simultaneously pressing the lower left and lower right touchscreen area for about 5 seconds, which gives user access to Service Menus. Use the following table to set each desired Service Menu item. Advanced configuration allows the user to configure the thermostat to match the system type and to customize several thermostat settings. System type for WineZone systems is 1 Stage Cool/1 Stage Electric Heat. Changed values are automatically retained. Press Done only if you wish to exit Advanced Configuration. Service menu availability is dependent upon system type and upon system configuration.

Menu	Feature	Options	Default	Recommended Setting
100	Schedule Format	0-3	1	0= Nonprogrammable
101	Daylight Saving Time	0,1	0	1= Enabled (2007 U.S. Format)
110	System Type	1-13	1	1= 1 Heat/1 Cool conventional
120	Fan Control (heating)	0,1	0	1= Electric furnace (thermostat controls heating fan)
150	Backlight	0,1	0	0= Backlight temporarily on
170	Remote Sensor	0-5	0	0= No sensor 1= Indoor sensor (if used)
180	Heat Pump Compressor Lockout	0-45	0	0= No sensor
190	Heat Pump Auxiliary Lockout	0-60	0	0= None
230	Furnace Filter Change Reminder	0; 30; 60; 90; 120; 365	0	0= Off
240	Number of Program Periods	2; 4	4	4= 4 Events per day
250	Clock Format	12 or 24	12	12= 12-hour clock mode
260	Temperature Format F or C	0,1	1	1= Fahrenheit
270	Fan Off Delay Heat	0-99	0	20= 20 Seconds
280	Fan Off Delay Cool	0-99	0	20= 20 Seconds
290	Range Low	50-90	50	50, Choose the lowest selectable setpoint
300	Range High	50-90	90	68, choose the highest selectable setpoint
310	Setback Low	Off, 50-82	55	0= Off
320	Setback High	Off, 58-90	90	0= Off
330	Zone Temp Offset	+/-9	0	0= No offset
340	Keypad Lockout	0-3	0	0= No Key pad lockout
341	Enable Pin Access	0,1	0	0= Disable
350	Fan Mode Enable	1-3	3	3= On or Auto: allows user to select
360	System Mode Enable	0-3	1	1= Off, Heat, Cool. Auto
370	Economizer/Outside Air Damper	0-4	0	0= Off
380	Minimum Deadband Adjustment	3-10	3	3= Selects change over deadband value between heating and cooling modes to prevent short cycling
390	Pre-Occupancy Purge	0-3	0	0= Select to energize fan for selected number of hours (0-3) prior to all occupied events.

395	Maximum Override Time Limit	0, 1-4	3	3= 3 Hours
400	Cycles Per Hour Cooling Stage 1	0-6	3	3= Defines number of cycles per hour for cooling
420	Cycles Per Hour Heating Stage 1	0-12	5	5= Defines number of cycles per hour for heating
460	Heat Recovery Rate	0-18	5	0= Disable ramp recovery
470	Cool Recovery Rate	0-18	5	0= Disable ramp recovery
480	Minimum Off Time	1-10	4	4= 4 Minutes off time for both heat and cool output
490	Humidity Control Enable *	0-3	2	Selects how humidity will be controlled. When dehumidify is enabled the Y2 terminal becomes dehumidify. Note: If option 3 is selected, Service Menu 491 becomes available. 0= Disable (Humidity not displayed on touchscreen). 1= Dehumidify 2= Humidify 3= Dehumidify and Humidify
491	Humidity Deadband	5-50	5	5= 5% RH deadband between humidify and dehumidify
500	Programmable/Intermittent Fan	0-2	0	0= Disable
510	Power Harvesting	0-3	0	0= No power harvesting available
520	Default Display Icons	0-4	0	0= Time, Temp, SP
530	Revision	-	-	Not Adjustable
540	Factory Default Reset	0,1	0	0=Disable
600	System Test Main Output (Cool)	0-2	0	0= Disable
610	System Test Main Output (Heat)	0-3	0	0= Disable
620	System Test Fan Output	0,1	0	0= Disable
630	System Test Emergency Output	0,1	0	0= Disable emergency output
640	System Test Economizer	0,1	0	0= Disable economizer output

***IMPORTANT! Some humidity control must be selected to view the humidity on the thermostat. If no humidity options are installed, DO NOT connect wires to terminals A or Y2. Only connect wire to A if a humidifier is installed. Do not connect wire to Y2.**

Mount the T12000 Onto the Wallplate

1. Position the thermostat slightly above the mounted wallplate, then secure the hooks on the backside of the thermostat to hinge pockets on the wallplate. **Note: The top of the thermostat should slip into the hinge pockets easily. Do not use excessive force.**
2. Align the pins on the back side of the thermostat with the terminal blocks on the wallplate.
3. Gently bring down the thermostat onto the wallplate so the pins on the back of the thermostat fit into the terminal blocks on the wallplate.

Verify Thermostat Operation

Press the desired button until the preferred selection blinks. Press Done to select and save the selection.

1. Set the system to Off. Nothing should operate, including the Fan.
2. Set the fan to Auto
3. Set the system to On. Press the up and down arrows to adjust the temperature. Adjust the temperature setpoint above the cellar temperature displayed on the touchscreen.
4. Set the Fan to On. The indoor fan should come on.
5. Set the Fan to Auto. The indoor fan should go off.
6. Adjust the temperature setpoint below the cellar temperature displayed on the touchscreen. The condenser and indoor fan should come on.
7. If a humidifier is installed, adjust the Humidity setpoint above the humidity displayed on the touchscreen. The humidifier should come on. Set the humidity setpoint below the humidity displayed on the touchscreen. The humidifier should go off.
8. Adjust the temperature setpoint above the cellar temperature displayed on the touchscreen. The condenser and indoor fan should go off. Nothing should be running.
9. Set the Humidity setpoint above the humidity displayed on the touchscreen. The humidifier should come on.
10. Set the temperature to 55° and the Humidity to 65%.

Humidifier Installation

Install the Wine Guardian® Freestanding Humidifier. Run the humidifier prior to installation as the warranty does not cover removal of the unit. Please read and understand the owner's manual and installation instructions prior to start up. Follow the manufacturer's manual to locate and mount the free-standing humidifier. Install the hot water line and drain according to the manufacturer's instructions.

Disregard wiring instructions that include humidistat wiring. The Wine Guardian® humidistat and transformer are not necessary when used with the WineZone thermostat. Cut off the plug end of the 24 volt control wire on humidifier and connect the wires directly to the terminals marked HUM on TB2 in the condenser control panel.

Do not install the humidifier directly underneath the evaporator. Do not install the humidifier where the evaporator will blow directly on the humidifier.

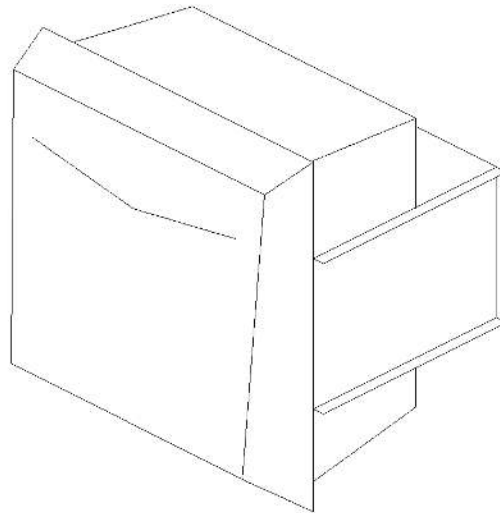

WZDS Condenser Control Panel

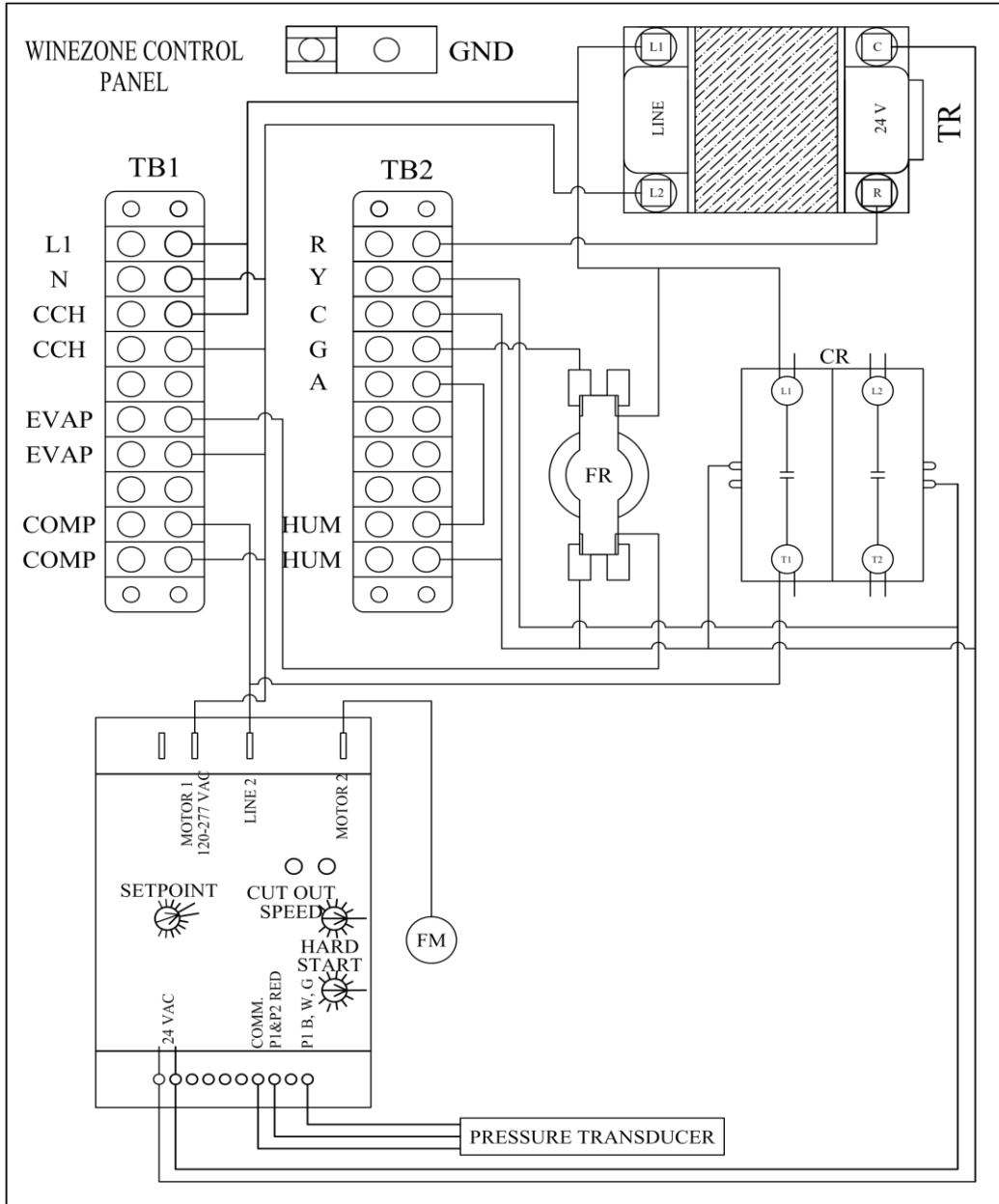

Legend		TB1		TB2	
COMP	Compressor	L1	115V Line voltage from service panel	R	Thermostat R
CR	Compressor relay	L2	115V Neutral from service panel	Y	Thermostat Y
CCH	Crankcase heater	CCH	Crankcase Heater	C	Thermostat C
FM	Fan motor	CCH	Crankcase Heater	G	Thermostat G
FR	Evaporator fan relay			A	Thermostat A, Humidity
GND	Ground	EVAP	115V Load voltage evaporator		
TB	Terminal Board	EVAP	115V Neutral to evaporator		
TR	Transformer				
		COMP	Compressor	HUM	Humidifier
		COMP	Compressor	HUM	Humidifier

Condenser Fan Speed Control

The WineZone condensing unit uses an ICM333 fan speed controller to maintain the proper head pressure.

When the condenser fan motor starts running it will start for a length of time dictated by the hard start dial setting. After the hard start time has elapsed, the motor speed is controlled by the pressure transducer reading. The green light turns on when the motor runs at full speed.

As the sensed pressure decreases, the output voltage decreases. The yellow light turns on during motor variable speed. The output voltage may decrease to the determined cutout speed dictated by the cutout speed dial. Upon reaching the cutout speed setting, the output voltage goes to zero volts and the yellow light turns off.

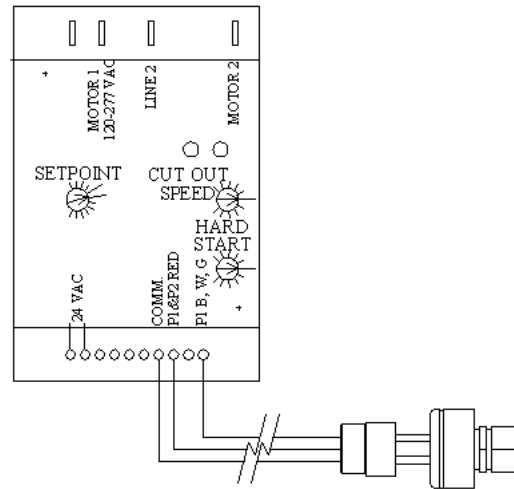

The fan cut out speed is factory set to the minimum speed for sleeve bearing motors.

The fan hard start time is factory set to the minimum for sleeve bearing motors.

Adjust the set point dial to maintain 140 psi head pressure when the condenser ambient is at or below 90° F. The control will maintain condenser pressure between 20 psig above and 20 psig below dialed Pressure Setpoint.

Make sure that supply voltage to the system and ICM333 Head Pressure Control are disconnected before installation or service.

The ICM Pressure Transducer is located on the receiver backseat valve. The backseat valve must remain open 1/2 to 1 full turn to allow the pressure transducer to sense the head pressure.

Installation Check List

1. Ensure the electric voltage, breaker and wire size are correct for all electrical components.
2. Make sure the line set is less than 200 equivalent feet in length, the proper diameter and contains no oil traps.
3. Make sure the line set has passed a leak test and has been evacuated below 1000 microns.
4. Check the evaporator drain and make sure it is clear of obstructions, free of traps, and has sufficient slope.

Quick Start Procedure

Caution: A qualified technician must install this refrigeration equipment. The following quick start procedure is not a substitute for proper installation techniques and procedures. Please read, understand, and follow all instructions in this manual prior to start up. Failure to install and adjust this refrigeration unit in compliance with the installation instructions will void the warranty.

1. Break the vacuum to a positive pressure of approximately 20 PSI. **DO NOT** start the unit for the first time with a full charge.
2. Apply power to the unit for 24 hours to allow the crankcase heater to warm the compressor.
3. Start the unit.
4. Slowly add charge to system through the compressor suction access port. **DO NOT** allow liquid refrigerant to directly enter the compressor. Use a metering device to prevent liquid from directly entering the compressor.
5. Adjust the condenser fan cycle control to maintain 140 PSI head pressure with condenser ambient temperatures at or below 90° F.
6. Continue to add refrigerant until the sight glass is clear.
7. Allow the unit run and cool the room to 55° F.
8. Compare the saturation temperature corresponding to the suction pressure at the compressor to the sensible suction line temperature at the compressor. Adjust the thermostatic expansion valve as necessary to ensure a superheat of 8° to 18°.
9. Add refrigerant to maintain approximately 5° of sub-cooling.
10. Check the discharge (hot gas) line temperature midway between the compressor outlet and condenser coil inlet. It should never exceed 225°.
11. Check the compressor amp draw. It should never exceed the RLA on the condensing unit rating plate.
12. Disconnect refrigerant gauges.

Normal Operating Pressures for R-134a		
Outdoor Temperature (°F Dry bulb)	Condenser Inlet Suction Pressure	Head Pressure
110	31	195
90	29	143
70	29	138*

Return air temperature of 55° dry bulb. Supply air temperature of 44° -47° dry bulb.

*Fan speed controller may influence head pressure.

Charge to 5 ° sub-cooling. Superheat 8-18 °

Approximate charge weight of 2.6 lbs. R134a refrigerant with 50' line set.
Approximate weight of R-134a per foot of 1/4" liquid line is 0.24 ounces.

Service and Maintenance
Maintenance Procedures

<u>Service Parts</u>		<u>Period</u>
Indoor Air Filter	1. Remove any dust on filter with vacuum cleaner or warm water and gentle detergent. Rinse and dry thoroughly before placing in unit.	Monthly
Evaporator	1. Clean dirt and debris from grille or panel with a soft cloth, soap, and water.	As necessary
	2. Inspect evaporator coil, gently remove, brush off dirt and debris	As necessary
	3. Check drain pan. Wipe or vacuum clean as necessary. Check water flow; blow out drain as necessary.	Monthly
Condenser	1. Wash condenser coil with appropriate cleanser and garden hose. Check safety devices. Check refrigerant charge. Check system operation	Twice per year By qualified technician

Trouble shooting

<u>Fault</u>	<u>Cause</u>	<u>Solution</u>
Unit does not run	1. Blown fuse or circuit breaker	Replace fuse/reset breaker
	2. Room at set point	Lower set point
	3. Thermostat not calling for cooling	Lower set point
	4. Faulty thermostat or wiring	Check low voltage wiring, replace thermostat
Unit runs but does not cool	1. Lack of air flow	Check filter, make sure louvers and fan are unobstructed. Clean evaporator if necessary
	2. Unit low on charge	Add refrigerant
	3. Compressor not running	Check compressor and starting components
	4. Unit undersized	Call a qualified technician
Evaporator coil freezes	1. Air filter dirty	Clean air filter
	2. Coil and/or fan wheel dirty	Clean the coil and/or fan wheel
	3. Temperature set point too low	Set thermostat to 55°
	4. Head pressure is too low	Adjust condenser fan speed controller to maintain 190 PSI head pressure.
	5. System low on charge	Add refrigerant
	6. Thermostatic expansion valve faulty or improperly set	Adjust TXV. See step #12 on page 6
Water leaking from unit	1. Condensate drain clogged	Clear out drain
	2. Evaporator coil frozen	See above
	3. Hole behind evaporator not sealed	Seal both sides of wall around line set, wiring, and drain
	4. Trap or no air gap in drain	Remove trap or install air gap in drain. See page 9

Evaporator fan runs but compressor does not	1. Compressor and/or starting components faulty	Call a qualified technician
Compressor runs but evaporator fan motor does not	1. Faulty fan motor	Replace fan motor
	2. Faulty fan relay	Replace fan relay
Compressor short cycles	1. Evaporator blows on thermostat	Move thermostat
	2. Unit low on charge	Add refrigerant
	3. Condensing fan motor/capacitor faulty	Replace condenser fan motor and/or capacitor
	4. Compressor and/or starting components faulty	Replace compressor and/ starting components
Super heat in evaporator too high	1. Unit low on charge	Add refrigerant
	2. Thermostatic expansion valve out of adjustment or faulty	Adjust TXV, see step #12 Replace TXV
Super heat in evaporator too low	1. Unit over charged	Reclaim refrigerant
	2. Evaporator coil frozen	See above
	3. Evaporator fan motor not running	See above
	4. Thermostatic expansion valve out of adjustment or faulty	Adjust expansion valve, see step #12, replace valve
Hot gas line temperature exceeds 225° or Suction pressure in evaporator too low or Suction line temperature at compressor too high	1. Thermostatic expansion valve out of adjustment or faulty	Check TXV operation. Lower superheat, see step #12
	2. Unit low on charge	Add refrigerant
Humidity in cellar too low	1. Cellar vapor barrier not sufficient	Install proper vapor barrier
Condenser fan motor short cycles	1. Condenser fan motor pressure control improperly set	Adjust condenser fan speed controller to maintain 195 PSI
	2. Condenser fan motor or capacitor faulty	Replace faulty fan motor or capacitor.
	3. Condenser fan speed controller does not sense pressure	Receiver backseat valve closed
	4. Unit low on charge.	Add refrigerant

A **qualified service technician** must record all of the information on the diagnostic sheet **before** calling for technical assistance. The technician **must** be able to identify the unit with the order number and serial numbers to receive accurate trouble shooting assistance. All recommendations for repair or adjustment will be based on the information provided by the **service technician**. Any incorrect recommendations based on incorrect or insufficient data are not covered by the warranty.

°F	R-134a PSIG		°F	R-134a PSIG
0	6.5		76	80.2
2	7.5		78	83.4
4	8.5		80	86.7
6	9.6		82	90.0
8	10.8		84	93.5
10	11.9		86	97.0
12	13.1		88	100.6
14	14.4		90	104.3
16	15.7		92	108.1
18	17.0		94	112.0
20	18.4		96	115.9
22	19.9		98	120.0
24	21.3		100	124.2
26	22.9		102	128.4
28	24.5		104	132.8
30	26.1		106	137.2
32	27.8		108	141.7
34	29.5		110	146.4
36	31.3		112	151.1
38	33.1		114	156.0
40	35.0		116	160.9
42	37.0		118	166.0
44	39.0		120	171.2
46	41.1		122	176.5
48	43.2		124	181.8
50	45.4		126	187.4
52	47.7		128	193.0
54	50.0		130	198.7
56	52.4		132	204.6
58	54.9		134	210.6
60	57.4		136	216.7
62	60.0		138	222.9
64	62.7		140	229.2
66	65.4		142	235.7
68	68.2		144	242.3
70	71.1		146	249.1
72	74.1		148	255.9
74	77.1		150	262.9

Superheat

Subtract the saturation or dew temperature corresponding to the suction pressure in the evaporator from the suction line temperature to determine superheat.

Adjust thermostatic expansion valve to maintain 8-18° superheat.

Sub-cooling

Charge to 5° sub-cooling and a full sight glass with R-134a

DIAGNOSTIC SHEET for customer order # _____

A qualified service technician must record all of the information on the diagnostic sheet before calling for technical assistance. The technician must be able to identify the unit with the order number and serial numbers to receive accurate trouble shooting assistance. The condenser fan motor must be running and the return air temperature must be between 53° and 58°F when recording this data.

Refrigerant: _____

Condenser Model # _____

Condenser Serial # _____

Evaporator Model # _____

Evaporator Serial # _____

Voltage at compressor: _____

Compressor amp draw: _____

Line set size: _____ X _____

Line set length: _____

Number of elbows in suction line, including all 45 and 90 degree bends in soft copper: _____

Suction pressure at compressor: _____

Head pressure: _____

Suction line temperature at compressor: _____

Discharge (hot gas) line temperature: _____

Liquid line temperature: _____

Condenser ambient temperature: _____

Return air temperature, see above: _____

Supply air temperature: _____

This area to be filled out for air handler installations only:

Supply trunk size: _____

Number and size of supply registers: _____ @ _____

Return air trunk line size: _____

Customer name: _____

For the property located at: _____

Diagnostic sheet filled out by: _____

Date: _____

Company: _____

Telephone # _____ Fax# _____ E-Mail _____

Wine Cellar Innovations 4575 Eastern Avenue Cincinnati, OH 45226 800-229-9813