

PLATINUM SPLIT

OMEGA

OWNER'S MANUAL

Platinum Split PS4000
Platinum Split PS8000

NOTICE: To activate the split system warranty, the installing certified HVAC/R service tech must complete the split system warranty checklist and send back to WhisperKOOL.

Split System Warranty Checklist



*Whisper***KOOL**[®]
The Future of KOOL

Conforms to ANSI/UL Std 427

Certified to CAN/CSA Std C22.2 No. 120

WhisperKOOL

“Engineered, Designed and Assembled in the USA”

WhisperKOOL products are composed of parts and materials that were imported to the United States and then assembled into the final products in Stockton, California.

Copyright © 2025. WhisperKOOL. All rights reserved.

WhisperKOOL copyrights this manual, the product design, and the design concepts, with all rights reserved. Your rights with regard to the hardware and manual are subject to the restrictions and limitations imposed by the copyright laws of the USA. Under copyright laws, this manual may not be copied, reproduced, translated, transmitted, or reduced to any printed or electronic medium or to any machine-readable form, for any purpose, in whole or in part, without the written consent of WhisperKOOL.

Every effort has been made to ensure that the information in this manual is accurate. WhisperKOOL is not responsible for printing or clerical errors.

WhisperKOOL reserves the right to make corrections or improvements to the information provided and to the related hardware at any time, without notice. Please visit our web site for the most current version of the WhisperKOOL manual and other literature.

Vinothèque and WhisperKOOL are registered trademarks, and ECE is a trademark of WhisperKOOL. All rights reserved.

Mention of third-party products is for informational purposes only and constitutes neither an endorsement nor a recommendation. WhisperKOOL assumes no liability with regard to the performance or use of these products.

TABLE OF CONTENTS

Introduction	3
Before You Start	4
Quick Start Guide	5
Receiving & Inspecting the System	6
Preparing the Wine Cellar	7
Quick Reference Guide	10
Unit Specifications	11
Evaporator Unit Installation	
Items to Route before Installing the Evaporator Unit	15
24V Thermostat Conversion Kit Wiring Instructions	16
Preparing the Wall-Mounted Evaporator Unit	17
Installing the Wall-Mounted Evaporator Unit	18
Preparing the Fully-Ducted Evaporator Unit	20
Installing the Fully-Ducted Evaporator Unit	21
Connecting The Lineset	23
Ducting Overview	25
Drain Line	27
Liquid-Measuring Thrmostat Sstem (Bottle Probe)	28
Remote Display Installation	
Wall Mount Bracket Installation	29
Flush Mount Bracket Installation	32
Wiring Diagrams	
Platinum - KDT	35
Platinum - 24V	36
Condensing Unit	37
Preparing the Condensing Unit	38
Installing the Condensing Unit	39
Charge Chart & TXV Adjustment	43
Display Layout	45
Controller Functions	46
Icon Glossary	47
Alarm Codes	48
User Menu	49
Troubleshooting Guide	50
Condenser Component Identification	52
System Operation (KDT)	54
System Operation (24V)	55
Maintenance Schedule	56
Technical Assistance	57
Warranty Information	58
Warranty Registration	63



WARNING



The evaporator unit (fan coil unit) must be insulated using the insulation blanket provided in accordance with this manual. Refer to the insulation blanket installation instructions.

Failure to follow the instructions provided will result in a poor vapor barrier, water damage, rust, and system corrosion which will void the warranty on your unit.

The evaporator unit (fan coil unit) must be insulated using fiberglass insulation (R19 or higher) in addition to the provided insulation blanket. This includes the cavity between the ceiling joists. A warm attic environment will reduce the capacity of the cooling system, as the system will absorb heat from the attic in addition to the heat load from the wine cellar. This, in effect, will significantly reduce the cooling system's ability to cool the wine cellar.

Failure to properly insulate the evaporator unit may cause condensation to form on the surface of the housing and water damage to the surrounding structure, the cooling unit, and possibly the wine cellar.

To avoid these issues, install the insulation kit and insulate the surface of the evaporator unit that is located outside of the wine cellar using fiberglass insulation.

***Additional insulation is required!**

INTRODUCTION

Customer Service

Thank you for purchasing a WhisperKOOL cooling system. We strive to provide the highest-quality products and the best possible customer service. WhisperKOOL Customer Service is available Monday through Friday from 6:00 a.m. to 4:30 p.m. PST. If you have any questions about your system, please email us at Support@WhisperKOOL.com.

Using the Manual

This manual is intended to assist in the proper maintenance of the cooling system. In order to ensure the longevity of your cooling unit, the equipment should be installed as outlined in the technician's manual. It is also vital to establish a proper care and maintenance schedule. Please read and review this manual carefully and keep it for future reference.

What is the WhisperKOOL Cooling System?

The WhisperKOOL cooling system is a specialized refrigeration system designed for one purpose only: to maintain the optimal temperature and humidity levels conducive to the proper storage and aging of fine wines. This system produces minimal in-cellar noise and has the most lenient exhaust requirements.

How Does the Cooling System Work?

Similar to the air conditioning systems used for homes, the evaporator unit and condensing units are installed in separate locations and are connected by a refrigerant line set. The evaporator portion is commonly installed in the wine cellar, with the condensing unit is located either outside or in a remote indoor location that is ventilated. An exterior housing is required for outdoor condensing unit installations.

Temperature Setting

The system is designed to maintain a cellar temperature of 55°F as long as the ambient temperature does not exceed 120°F.

WARRANTY REGISTRATION

In order to activate the warranty of your system, the verification and operational documentation must be completed by the certified refrigeration technician installing your system and submitted via mail, fax, or e-mail.

Mail to:
WhisperKOOL
ATTN: Warranty Registration
1738 E. Alpine Avenue
Stockton, CA 95205-2505
USA

Fax to:
209-466-4606

Scan and email to:
warranty@whisperkool.com

BEFORE YOU START

1-800-343-9463

1. **Inspect all components prior to installation.** If damage is found, please contact your distributor or WhisperKOOL Customer Service at 1-800-343-9463.
2. The evaporator units **require a dedicated 115V, 10-amp circuit.** Use a surge protector with the system. **Do not use a GFI** (ground fault interrupter) line.
 - The Mini Omega condensing unit requires a dedicated 115V, 15-amp circuit.
 - The 4000 Omega condensing unit requires a dedicated 115V, 15-amp circuit.
 - The 8000 Omega condensing unit requires a dedicated 115V, 20-amp circuit.
3. You are **REQUIRED** to **install a drain line** to remove condensation from the evaporator units.
4. No communication cables are required between the evaporator and condensing units.
5. ***The warranty is not active until a warranty checklist has been received, reviewed, and approved.***
6. The system is intended **for use in properly designed and constructed wine cellars.** Hire a professional wine storage consultant with a valid contractor's license to build your wine cellar.
7. WhisperKOOL requires that all split systems be installed by a certified HVAC-R technician only. NATE or equivalent is recommended.
8. ***It is vital that the units be set apart and oriented so that the return air from one unit does not recirculate into the supply air of the other unit.***

If you encounter a problem with your WhisperKOOL system, please refer to the Troubleshooting Guide. If you have any further questions or concerns, or need assistance, please contact WhisperKOOL's Customer Service at 1-800-343-9463. Please be sure all testing has been completed prior to contacting Customer Service. Please have your results ready for your representative.

QUICK START GUIDE*

Pump-down Cycle

WhisperKOOL's split systems operate on a pump-down cycle different from traditional air conditioners. As such, there is no wiring between the condensing unit and evaporator unit.

WhisperKOOL units utilize a solenoid valve on the liquid line and a low-pressure switch on the suction line. When the thermostat calls for cooling, the solenoid valve opens, permitting the flow of refrigerant. The low-pressure switch then signals the compressor to cycle on.

When the cellar reaches the desired temperature and the thermostat is satisfied, the solenoid will close, stopping the liquid refrigerant flow to the TXV valve. The compressor will continue to operate until most of the refrigerant on the low side boils off and is pumped through the compressor into the condenser coil and receiver. As the suction pressure falls below the pressure control setting, the low-pressure switch will signal the compressor to cycle off. Most of the refrigerant is now stored between the condensing unit and receiver.



WARNING: Do not utilize a ground fault interrupter, as it will prevent the unit from drawing the amperage necessary to start the unit.



TXV Adjustments

- A. A TXV adjustment may be necessary based on ambient temperatures in the cellar and at the condensing unit.
- B. Adjust the TXV until the superheat measured at the suction line service valve is 16-30°F.
- C. Under normal operation, with the wine cellar at 55°F and the ambient temperature at 85°F.

TXV

The TXV is preadjusted at the factory. If the superheat is not within 16-30 at the service valve, Adjust as necessary.

ADJUSTING THE TXV

TXV is adjusted with a flat head driver. Increase superheat by turning the flat head clockwise. Decrease superheat by turning the flat head counterclockwise.



Liquid Line King Valve

This location is used to charge the system with liquid refrigerant and identify the high side pressure of the system.

Calculating Subcooling

To determine the subcooling of the system, calculate the difference between the **high side pressure of the system (converted to temperature)** and the **temperature of the liquid line**. The temperature of the liquid line will be taken at the outlet of the liquid king valve.

*Saturation temp — liquid line temp

3-12°F SUBCOOLING REQUIRED FOR WARRANTY APPROVAL

RECEIVING & INSPECTING THE SYSTEM

- Use caution when lifting and check package for damage.
- Lift only at the designated hand-hold locations on the shipping container, or fully support the unit from underneath. A shipment may include one or more boxes containing accessories.
- Before opening the container, inspect the packaging for any obvious signs of damage or mishandling.
- Write any discrepancy or visual damage on the bill of lading before signing.
- Allow the condensing unit to sit for 24 hours prior to start-up. The condensing unit can be placed in the installation location, piped and evacuated during this time.
- Review the packing slip to verify contents.
- Check the model number to ensure it is correct.
- Check that all factory options ordered are listed.

If any items listed on the packing slip do not match your order information, contact WhisperKOOL Customer Service immediately.

Check all shipped boxes for the following contents:

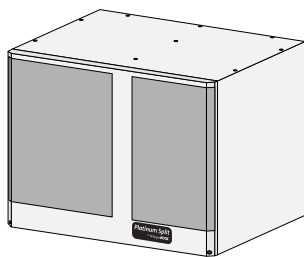

(1) Evaporator unit

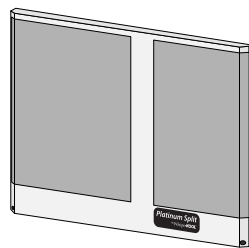

(1) Filter Grille

OR

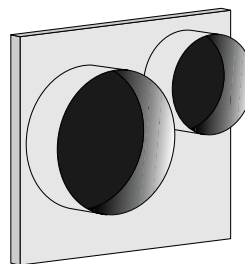

(1) Duct Plenum



(1) Omega Condenser

Documentation bag:

- Platinum Split owner's manual
- R-134a split system warranty checklist
- Evaporator unit installation template

Accessory kit bag:

- Evaporator installation hardware bag

KDT unit only

- Stainless steel probe (50 feet)
- KDT Plus display cable (50 feet)
- KDT Plus wall mount bracket assembly
- KDT Plus flush mount bracket assembly
- KDT Plus display assembly
- Flush mount template
- KDT Plus hardware bag

Evaporator installation hardware bag:

- (2) 1/2" x 1/2" nylon barbed fitting
- (1) 1/2" barbed tee
- (1) Double-D strain relief
- (4) 1/4" adhesive cable tie mounts
- (2) Small cable ties
- (4) #8 x 1 3/4" hex-head screws

KDT Plus hardware bag:

- (1) 1/16" OD grommet
- (2) 1/2" nylon hole plug
- (4) #6 x 1" Phillips zinc Type A screw
- (4) 8-10 x 7/8" blue plastic screw anchor

Please leave the unit in its original box until you are ready for installation. This will allow you to move the product safely without damaging it. When you are ready to remove the product from the box, refer to the installation instructions.

TIP: Save your box and all packaging materials. They provide the only safe means of transporting/shipping the unit.

PREPARING THE WINE CELLAR

The performance and life of your system is contingent upon the steps you take in preparing the wine cellar. Improperly preparing your enclosure or incorrectly installing your unit may cause unit failure, leaking of condensation, and other negative side effects.

It is highly recommended that you obtain the assistance of a wine storage professional.

Wine storage professionals work with licensed contractors, refrigeration technicians, and racking companies to build well-insulated, beautiful, and protective wine cellars. WhisperKOOL has put together some useful tips to assist in the installation process. Our recommendations are meant to act as a guide in the process of building a proper wine cellar. Your intended location may have specific needs which we do not address.

Wall & Ceiling Framing

Build wine cellar walls using standard 2x4 or 2x6 boards and ceiling joists without violating local or state codes in your area. As a general rule, the thicker the walls and the higher the insulation value, the more consistent your cellar temperature will be.

Insulation

Insulation is **REQUIRED** in order to properly use WhisperKOOL products. It is vital that all walls and ceilings be insulated to keep the cellar temperature as consistent as possible during the summer and winter months. Standard fiberglass or rigid foam insulation is normally used in cellar construction; in some cases, "blown-in" insulation is used. The R-value, or quality of insulation, is determined by the rate at which heat passes through the insulation. The higher the R-value, the more resistant the insulation is to conducting heat, and the more consistent your wine cellar temperature will be. Using higher R-values in insulation will lower your operating costs and WhisperKOOL unit run time. (R-13 is the recommended minimum; R-19 is preferred for interior cellar walls, and R-30 for ceilings and exterior walls.)

Vapor Barrier

Water vapor creates its own pressure, separate from the ambient air pressure, and will infiltrate into colder/drier areas. A vapor barrier is **REQUIRED** in order to prevent the intrusion of water vapor and maintain the correct cellar temperature and humidity. It is recommended that 6-millimeter plastic sheeting be applied to the warm side of the cellar walls. The vapor barrier must also be applied to the outside walls and ceiling. If it is impossible to reach the outside, then the plastic must be applied from within the cellar. The most common method is to wrap the entire interior, leaving the plastic loose in the stud cavity so the insulation can be placed between each stud. All of the walls and ceiling must be wrapped in plastic for a complete vapor barrier.

In areas of high humidity, such as Southern and Gulf States, the vapor barrier will prevent infiltration of warm moist air. The moist air can cause mold to form, and standing water in drain pans promotes microbial and fungal growth, which can cause unpleasant odors and indoor air quality problems. If mold is found, remove it immediately and apply a biocide to all areas.

Note: High humidity significantly increases the heat load on the cooling system.

Any break in the vapor barriers (cut, nail hole, over-lapping, etc.) will cause a moisture load and heat load on the cooling system. It is critical that a vapor barrier is intact. The conduit should be insulated and sealed on the warm air end.

WhisperKOOL™

PREPARING THE WINE CELLAR, CONTINUED

Unobstructed Airflow

Unobstructed airflow to and from the system is critical for the system's overall performance and lifespan. A minimum of 3 feet of clearance around the unit is crucial (5 feet is ideal). The air blown by the fans needs to circulate and either dissipate or absorb heat from the space. The system will operate more efficiently with a greater amount of air to exchange.

Note: Avoid attempting to camouflage the unit. This will restrict airflow, and thus the system's ability to work efficiently.



Door and Door Seal

An exterior-grade (1¾") door must be installed as a cellar door. It is very important that weather stripping is attached to all four sides of the doorjamb. A bottom "sweep" or threshold is also required. The door must have an excellent seal to keep the cool cellar air from escaping the cellar. If the door is not sealed properly, the cooling system may run continuously, shortening its operational lifespan.

In cases where glass doors are used and the room size is close to the recommended system size, the next larger size WhisperKOOL system should be used. This will compensate for the insulation loss due to the lower insulation rating of glass.

Ventilation

The necessity of dissipating heat away from the condensing unit is critical to the unit's performance and cannot be overstated. As the system operates and cools, a greater amount of heat is generated on the condensing side of the system. Adequate ventilation is required in order to dissipate heat away from the condensing unit. If ventilation is inadequate, the exhaust will heat the area or room and adversely affect the system's ability to cool. In some cases, it may be advisable to install a vent fan to dissipate heat within the exhaust area on the condensing side of the system. However, you must have a fresh air inlet as well.

Note: If you are unsure whether you have adequate ventilation in your installation location, please contact us at support@whisperkool.com or 1-800-343-9463.

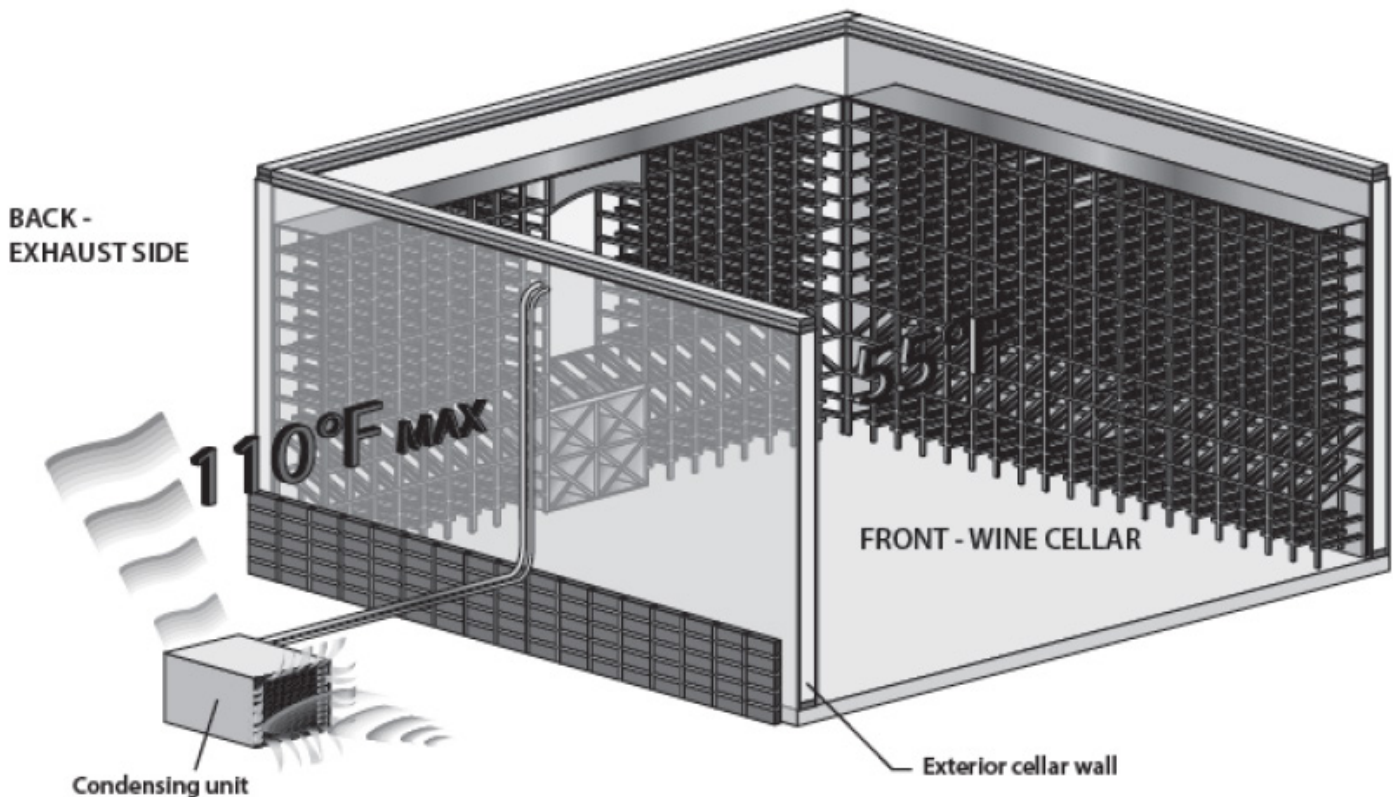

Ambient Temperature Factor

The cooling system has the ability to cool a wine cellar efficiently to 55°F as long as the ambient temperature of the area that it is exhausting to does not exceed 110°F. Therefore, you want the condensing unit to exhaust in a space which will not exceed 110°F and will allow for proper dissipation of the heat exhausted by the condensing unit. Without proper heat dissipation, the system will not have the capacity to keep the wine at a desirable 55°F.

WARNING! Allowing your system to operate in high ambient temperatures for extended periods of time will greatly decrease the life of your system and void your warranty. The cooler the temperature of the air entering the condenser coil, the more cooling capacity the system has. The lower the heat gain through a common wall, the lower the consumption of electricity.

WhisperKOOL™

QUICK REFERENCE GUIDE

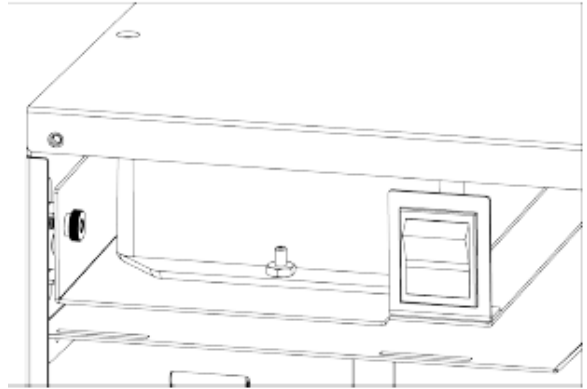

Fan Speed Switch

The cooling system comes equipped with a variable fan speed switch. Increasing the fan speed increases the volume of cool air blown from the system. It is set by the factory to MED. To access the fan speed switch it is necessary to remove the front grille.

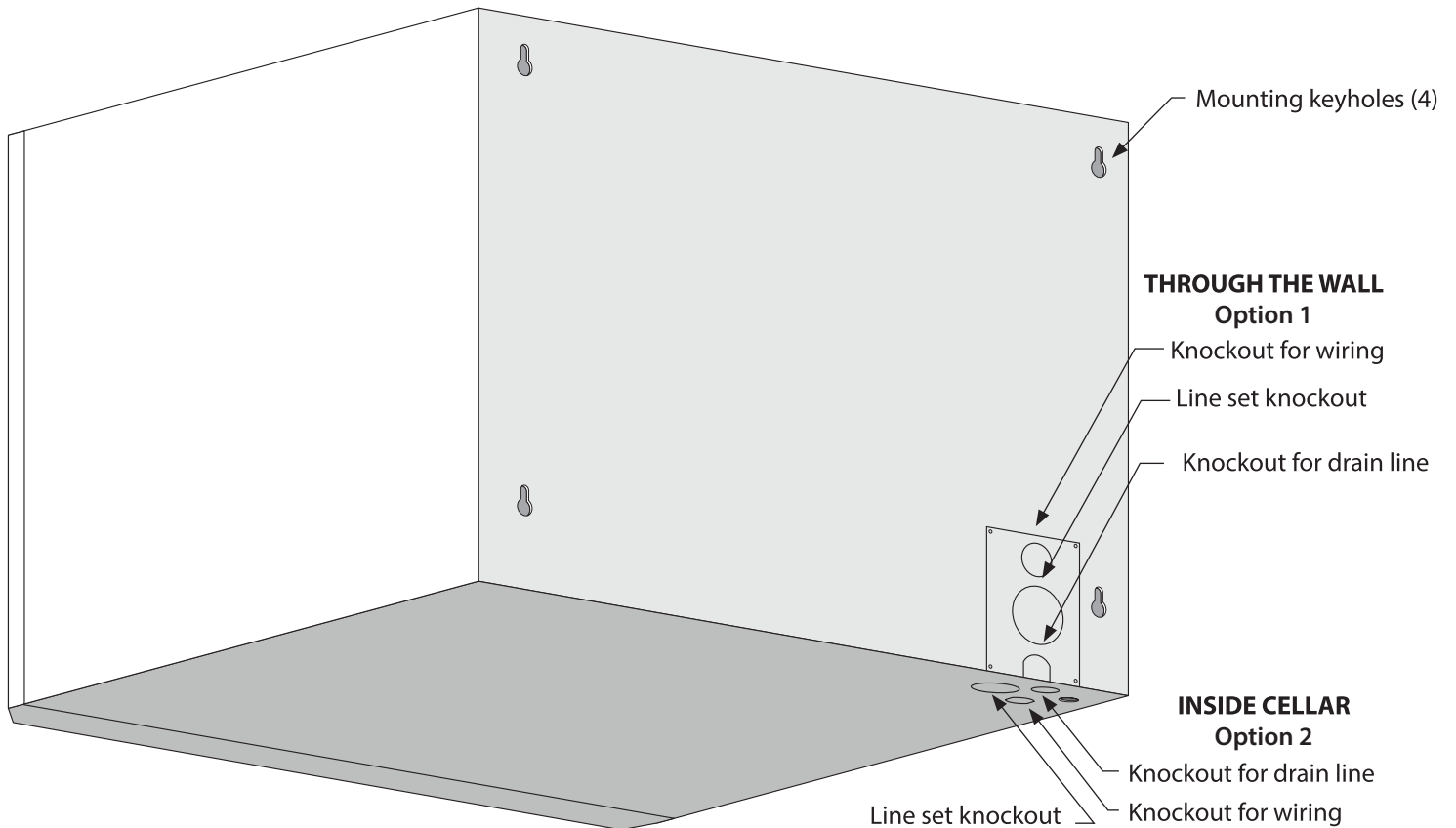
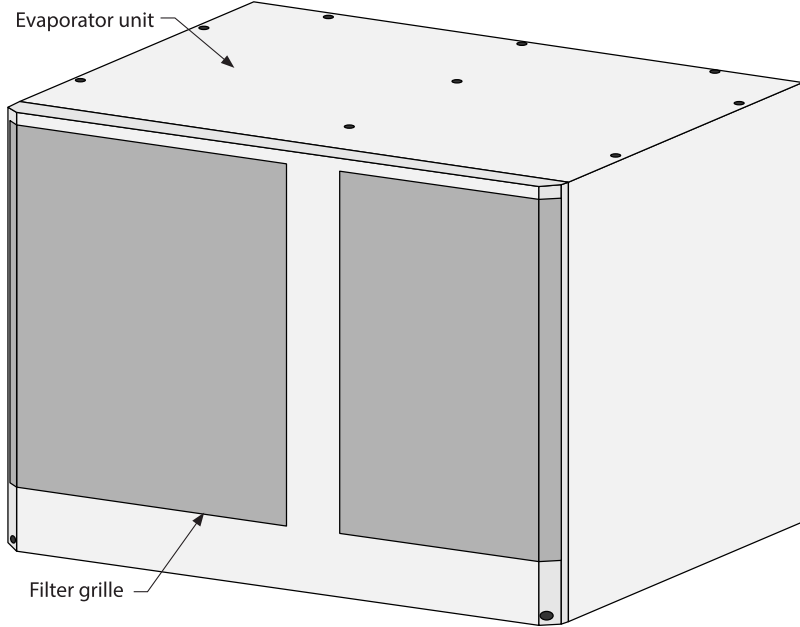

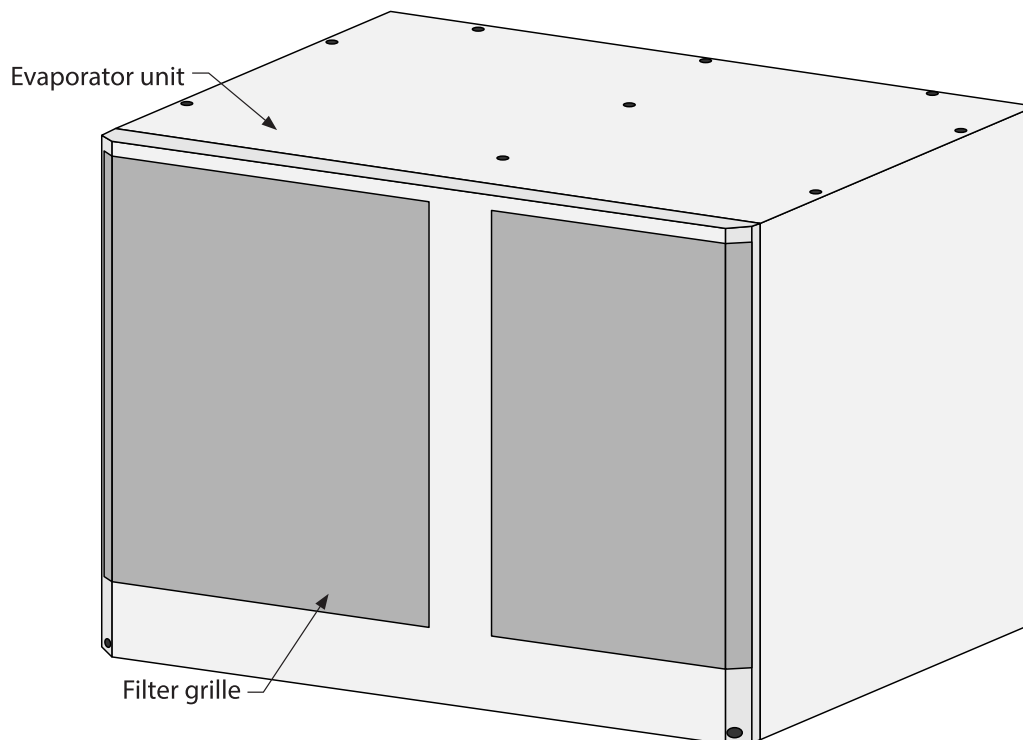

PLATINUM SPLIT 4000 WALL-MOUNTED SPECIFICATIONS

Model	Platinum Split Evaporator (Fan Coil Unit)	Omega Condenser (Air-Cooled Condensing Unit)
Cellar Size	Approx. 1000 cu. ft. when cellar is fully insulated and sealed with a proper vapor barrier.*	
BTU/h w/65°F air entering condenser coil	Low: 4565/5273 • Med: 4786/5488	Omega Condenser 4000 (Air-Cooled Condensing Unit)
BTU/h w/75°F air entering condenser coil	Low: 4177/4561 • Med: 4601/4669	
BTU/h w/85°F air entering condenser coil	Low: 3957/4315 • Med: 4244/4453	
Dimensions	16.1" L x 20.5" W x 15.5" H	23" L x 15.75" W x 15.3" H
Refrigerant	R-134a	
Condensing Unit HP	0.5 HP	
Voltage Rating	120V (15-amp dedicated circuit required)	120V (15-amp dedicated circuit required)
Weight	54 lbs	75 lbs
Amps	2.2 Running Amps	8.5 running amps
Line Set	Liquid line ¼" OD; Suction line ½" OD (less than 50ft.), ⅝" (greater than 50ft.)	
Drain Line	½" ID clear plastic tubing (not provided) - Rigid tube recommended	
Installation	Evaporator unit is installed in the cellar. Condensing unit can be installed up to 100 line feet from the evaporator unit.	
Thermostat	KDT- Advanced digital display (50-ft. cable), liquid-temperature-measuring bottle probe (50-ft. cable), 24V - Customer supplied.	
Temp. Delta	Can maintain a 55°F cellar temperature with up to 120°F condenser air intake temperature.	
Warranty	Two-year limited warranty (parts and labor).	

PLATINUM SPLIT 8000 WALL-MOUNTED SPECIFICATIONS

Model	Platinum Split Evaporator (Fan Coil Unit)	Omega Condenser (Air-Cooled Condensing Unit)
Cellar Size	Approx. 1750 cu. ft. when cellar is fully insulated and sealed with a proper vapor barrier.*	
BTU/h w/65°F air entering condenser coil	Low: 4814/5687 • Med: 5133/5777	Omega Condenser 8000 (Air-Cooled Condensing Unit)
BTU/h w/75°F air entering condenser coil	Low: 4455/4997 • Med: 4607/5012	
BTU/h w/85°F air entering condenser coil	Low: 4370/4834 • Med: 4577/4982	
Dimensions	16.1"L x 20.5"W x 15.5"H	23 "L x 15.75 "W x 15.3 "H
Refrigerant	R-134a	
Condensing Unit HP	0.5+ HP	
Voltage Rating	120V (15-amp dedicated circuit required)	120V (20-amp dedicated circuit required)
Weight	54 lbs	86 lbs
Amps	2.2 Running Amps	9.5 Running Amps
Line Set	Liquid line ¼" OD; Suction line ½" OD (less than 50ft.), ⅝" (greater than 50.ft)	
Drain Line	½" ID clear plastic tubing (not provided) - Rigid tube recommended	
Installation	Evaporator unit is installed in the cellar. Condensing unit can be installed up to 100 line feet from the evaporator unit.	
Thermostat	KDT- Advanced digital display (50-ft. cable), liquid-temperature-measuring bottle probe (50-ft. cable), 24V - Customer supplied.	
Temp. Delta	Can maintain a 55°F cellar temperature with up to 120°F condenser air intake temperature.	
Warranty	Two-year limited warranty (parts and labor).	

*Sizing the System to the Room

There are several factors such as glass, stone, and concrete which will change the required amount of BTUs needed to properly cool your wine room. We strongly recommend utilizing the cellar wizard on the WhisperKOOL website in order to ensure you are selecting the proper cooling system for your application. Under-sizing your cooling system can lead to premature failure and/or prevent the system from reaching the desired set temperature.

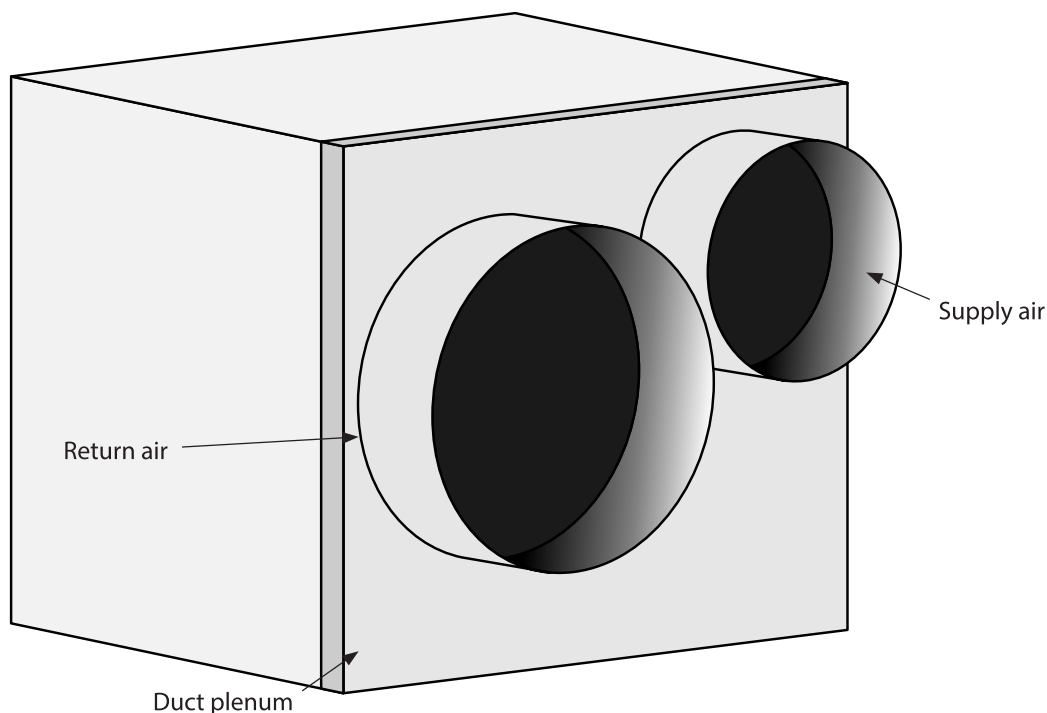

PLATINUM SPLIT 4000 FULLY-DUCTED SPECIFICATIONS

Model	Platinum Split Evaporator (Fan Coil Unit)	Omega Condenser (Air-Cooled Condensing Unit)
Cellar Size	Approx. 1000 cu. ft. when cellar is fully insulated and sealed with a proper vapor barrier.*	
BTU/h w/65°F air entering condenser coil	Low: 4463/5154 • Med: 4724/5337	Omega Condenser 4000 (Air-Cooled Condensing Unit)
BTU/h w/75°F air entering condenser coil	Low: 3912/4348 • Med: 4351/4544	
BTU/h w/85°F air entering condenser coil	Low: 3766/4096 • Med: 4082/4277	
Dimensions	22.1 "L x 22.5 "W x 15.5 "H	23 "L x 15.75 "W x 15.3 "H
Refrigerant	R-134a	
Condensing Unit HP	0.5 HP	
Voltage Rating	120V (15-amp dedicated circuit required)	220V (15-amp dedicated circuit required)
Weight	54 lbs	75 lbs
Amps	2.2 Running Amps	8.5 running amps
Line Set	Liquid line ¼" OD; Suction line ½" OD (less than 50ft.), ⅝" (greater than 50ft.)	
Drain Line	½" ID clear plastic tubing (not provided) - Rigid tube recommended	
Installation	Evaporator unit is installed in the cellar. Condensing unit can be installed up to 100 line feet from the evaporator unit.	
Thermostat	KDT- Advanced digital display (50-ft. cable), liquid-temperature-measuring bottle probe (50-ft. cable), 24V - Customer supplied.	
Temp. Delta	Can maintain a 55°F cellar temperature with up to 120°F condenser air intake temperature.	
Warranty	Two-year limited warranty (parts and labor).	

PLATINUM SPLIT 8000 FULLY-DUCTED SPECIFICATIONS

Model	Platinum Split Evaporator (Fan Coil Unit)	Omega Condenser (Air-Cooled Condensing Unit)
Cellar Size	Approx. 1750 cu. ft. when cellar is fully insulated and sealed with a proper vapor barrier.*	
BTU/h w/65°F air entering condenser coil	Low: 4641/5415 • Med: 4724/5337	Omega Condenser 8000 (Air-Cooled Condensing Unit)
BTU/h w/75°F air entering condenser coil	Low: 4427/4839 • Med: 4351/4544	
BTU/h w/85°F air entering condenser coil	Low: 4322/4798 • Med: 4082/4272	
Dimensions	22.1 "L x 22.5 "W x 15.5 "H	23 "L x 15.75 "W x 15.3 "H
Refrigerant	R-134a	
Condensing Unit HP	0.5+ HP	
Voltage Rating	120V (15-amp dedicated circuit required)	120V (20-amp dedicated circuit required)
Weight	54 lbs	86 lbs
Amps	2.2 Running Amps	9.5 Running Amps
Line Set	Liquid line ¼" OD; Suction line ½" OD (less than 50ft.), ⅝" (greater than 50ft)	
Drain Line	½" ID clear plastic tubing (not provided) - Rigid tube recommended	
Installation	Evaporator unit is installed in the cellar. Condensing unit can be installed up to 100 line feet from the evaporator unit.	
Thermostat	KDT- Advanced digital display (50-ft. cable), liquid-temperature-measuring bottle probe (50-ft. cable), 24V - Customer supplied.	
Temp. Delta	Can maintain a 55°F cellar temperature with up to 120°F condenser air intake temperature.	
Warranty	Two-year limited warranty (parts and labor).	

*Sizing the System to the Room

There are several factors such as glass, stone, and concrete which will change the required amount of BTUs needed to properly cool your wine room. We strongly recommend utilizing the cellar wizard on the WhisperKOOL website in order to ensure you are selecting the proper cooling system for your application. Under-sizing your cooling system can lead to premature failure and/or prevent the system from reaching the desired set temperature.

ITEMS TO ROUTE BEFORE INSTALLING THE EVAPORATOR UNIT

1. Route the line set from the condensing unit to the desired evaporator unit installation location.
2. Route the display cable from the desired location to the evaporator installation location
3. Route the bottle probe cable from the desired thermostat bottle location to the evaporator unit installation location.
4. Route the drain line from a proper discharge location to the evaporator unit installation location
5. Route the power cable wiring to the evaporator unit installation location.

ITEMS TO ROUTE

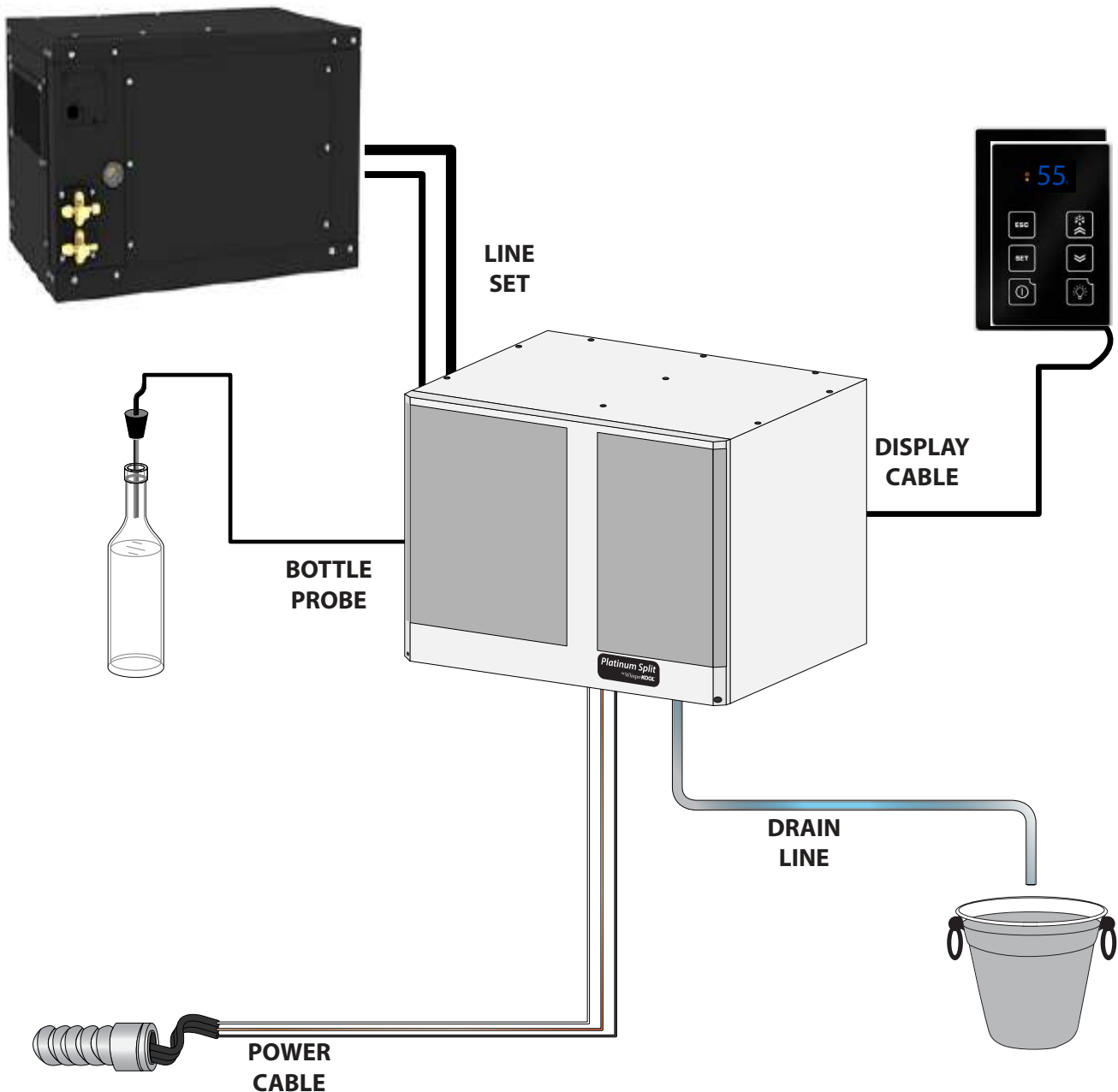

24V WIRING CONNECTIONS (EVAPORATOR UNIT)

The 24V thermostat conversion kit requires a standard 18-5 thermostat wire to be run from the evaporator unit to the thermostat. The white wire will not be used, as there is no heating function. (Some thermostats need a common wire and some do not; the unit is equipped with a common wire if needed.) 18-5 thermostat wire (communication cable) must be run between the evaporator unit and the condensing unit.

24V Wiring Connections (Evaporator Unit)

1. Route a standard 18-5 thermostat wire into the evaporator unit.
2. Locate the wire thermostat connection cable inside of the evaporator unit.
3. Connect the wires according to color (red to red, green to green, and blue to blue). **NOTE:** The evaporator will not contain a yellow wire. See the next step for more information on the yellow wire.

Thermostat Wiring Connections

Follow the thermostat installation instructions. **NOTE:** The white wire will not be used, as there is no heating function.

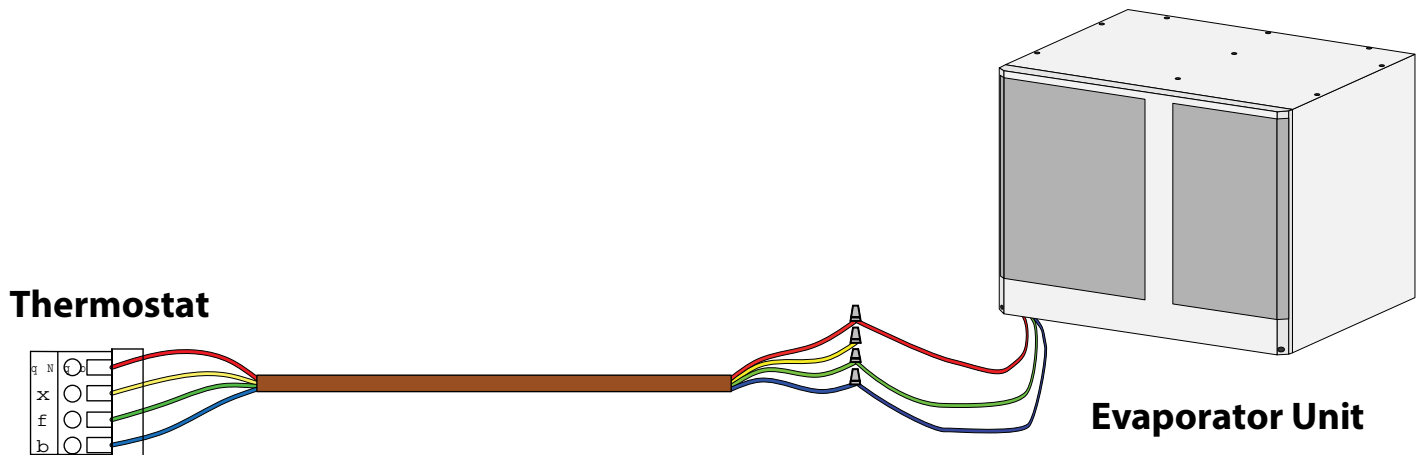

NOTE: To ensure correct system operation, the 24V thermostat must be placed inside the wine cellar, preferably in a central location away from any airflow.

PREPARING THE WALL-MOUNTED EVAPORATOR UNIT

Required Tools:

- Drill
- 5/32" drill bit
- 1/4" socket drill bit
- 1/4" wrench
- Phillips-head screwdriver
- Tape measure
- Drywall saw
- Ladder
- Level
- Pliers
- Pencil

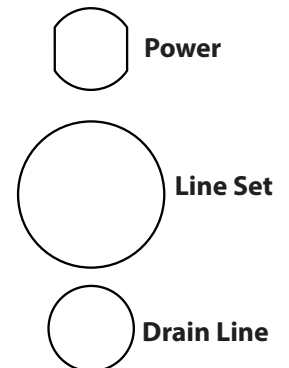
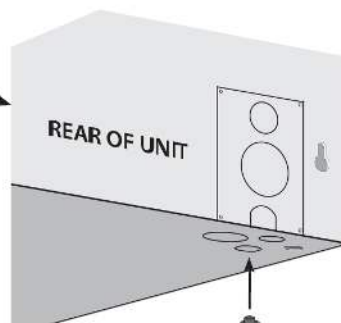
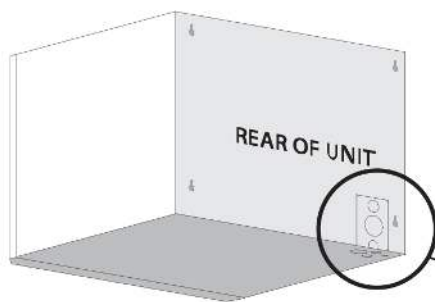
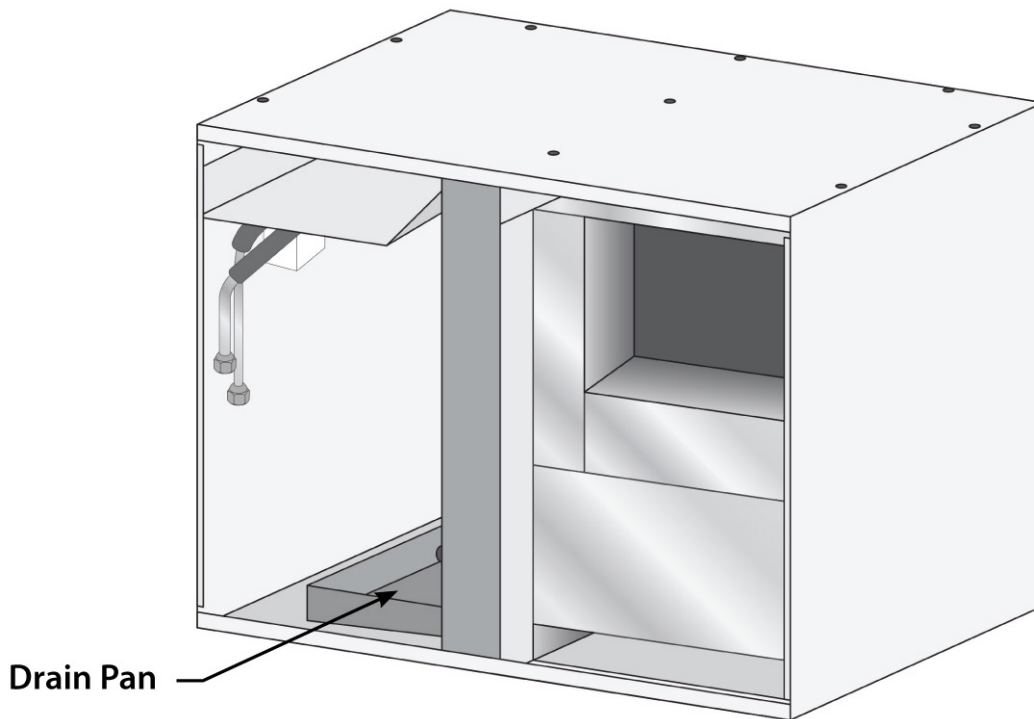

1. Remove the knockouts that you will be using to route the line set, power wires, display cable, bottle probe, and drain line.
2. Remove the insulation from the knockout holes.
3. For ease of installation, remove the nine (9) screws securing the top and remove the top.

INSTALLING THE WALL-MOUNTED EVAPORATOR UNIT

Note: The evaporator is designed to be mounted on two standard wall studs spaced 16" apart.

1. Locate two (2) wall studs in the desired mounting location.
2. Mark vertical lines on each stud 16" apart.

Note: The top of the unit must be installed a minimum of 6" and a maximum of 18" from the ceiling.

3. Mark an intersecting horizontal line at the desired height of the unit.
4. Make a mark on each stud 13½" down from the intersection of the horizontal and vertical lines.
5. Install the four (4) supplied 1¾" hex-head screws into the studs at the locations marked leaving 1/8" between the wall surface and screw head.
6. If routing through a wall, cut out an access hole for the line set, drain line, display cable, and power wires.
7. Raise the evaporator to the installation location. Align the rear keyholes with the mounting screws and mount the unit.
8. Using a 1/4" wrench or socket, tighten the top mounting screws.

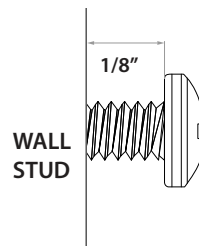
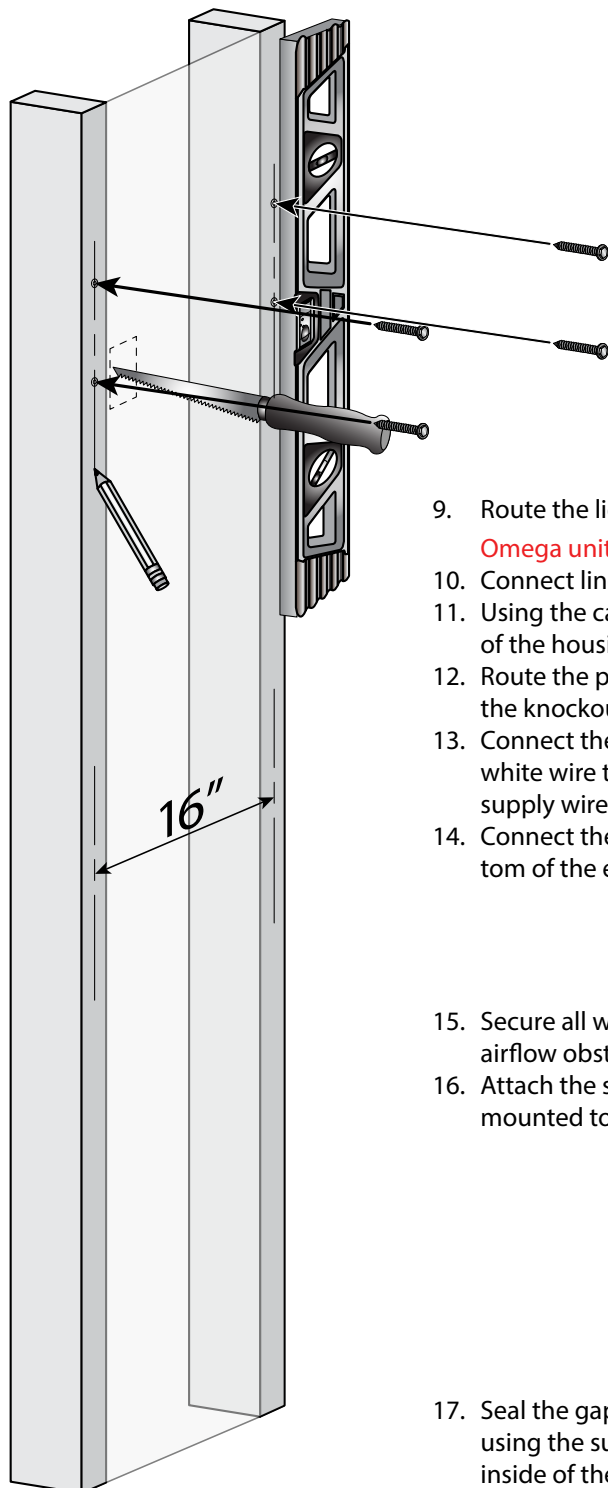

9. Route the liquid and suction lines through the knockouts in the housing **towards the Omega unit.**
10. Connect line set to the unit using the line set **connection instructions.**
11. Using the cable ties and cable tie mounts provided, secure the drain line to the bottom of the housing to ensure a downward slope.
12. Route the power wire, bottle probe connector, and display cable into the unit through the knockouts.
13. Connect the green wire to the green wire, the black wire to the black wire, and the white wire to the white wire. Install the supplied black strain relief to secure the power supply wires in the housing.
14. Connect the display cable labeled "UNIT" to the wire labeled "UNIT" located in the bottom of the evaporator compartment.



15. Secure all wiring neatly and as close to the left wall as possible in order to minimize airflow obstruction.
16. Attach the supplied bottle probe to the circular connector located on the small bracket mounted to the side wall in the evaporator compartment.

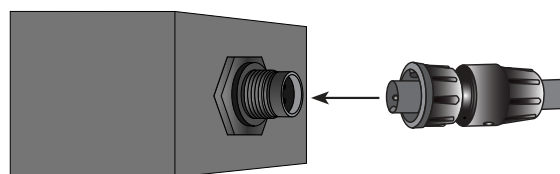

17. Seal the gaps around the display cable, bottle probe cable, and power wire knockouts using the supplied three-inch pieces of cork tape. (For best results, install the cork tape inside of the unit.)

INSTALLING THE WALL-MOUNT KIT

1. If removed, reinstall the top panel of the unit housing.
2. Align the front grille with the four (4) ball studs on the housing. Push the front grille onto the ball studs until it snaps into place.
3. Using a Phillips-head screwdriver, fasten the two (2) screws to fasten the grille to the unit.

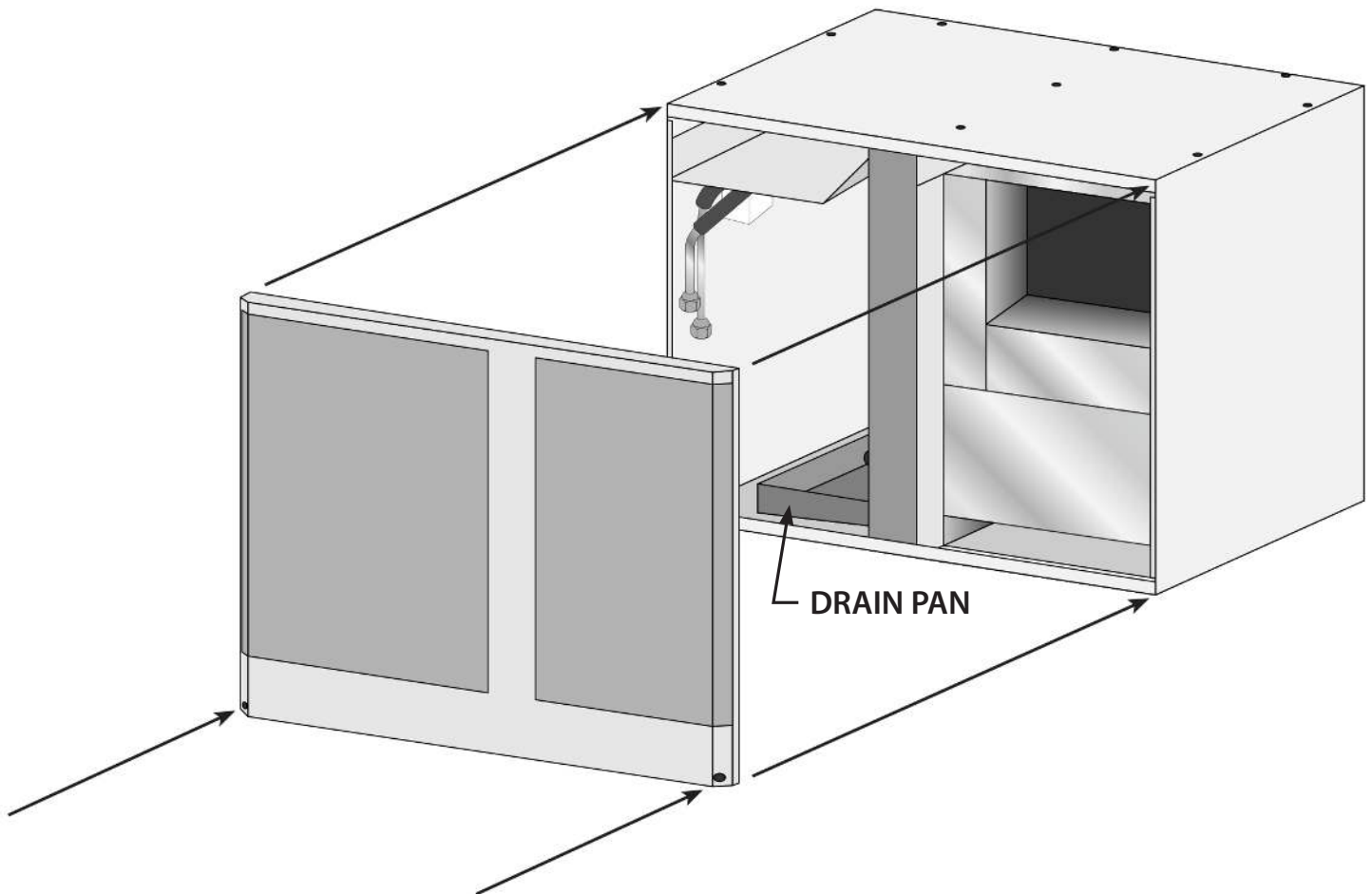

INSTALLING THE DUCTED PLENUM

1. If removed, reinstall the top panel of the unit housing.
2. Align the front grille with the four (4) ball studs on the housing. Push the front grille onto the ball studs until it snaps into place.
3. Using a Phillips-head screwdriver, fasten the two (2) screws to fasten the grille to the unit.
4. Connect the supply and return duct work to the unit.
5. Using duct tape or foil tape, seal the seam between the plenum and unit.
6. Insulate all exposed metal on the unit to prevent surface condensation.

Note: Max ducting length is 25 feet.

Note: A 12" x 12" return air filter grille must be installed to prevent contaminants from entering the cooling system. Supply and return ducts must be insulated so they do not sweat or pick up heat.

PREPARING THE FULLY-DUCTED EVAPORATOR UNIT

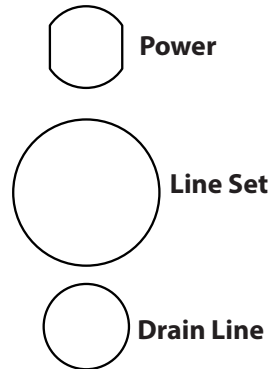
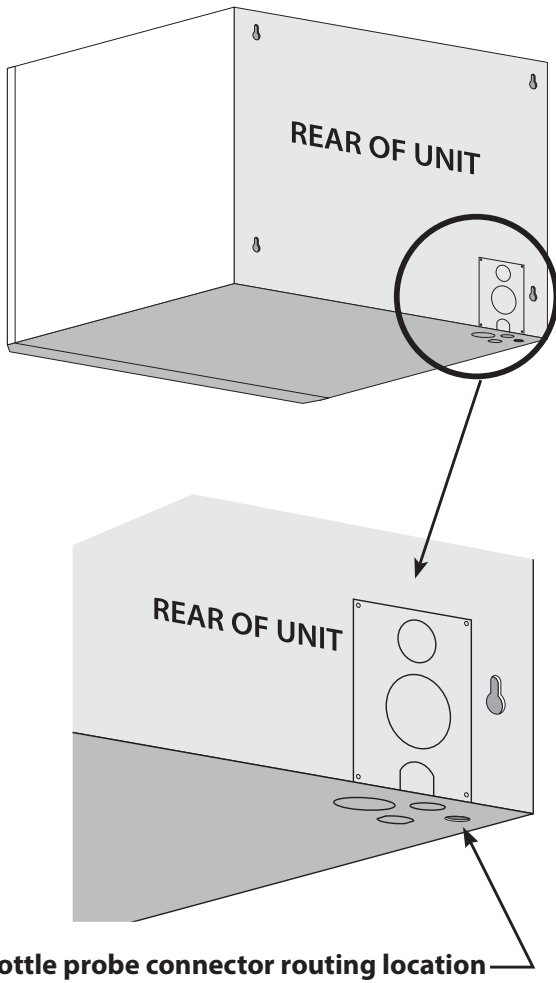

1. Remove the knockouts that you will be using to route the line set, power wires, display cable, bottle probe, and drain line.
2. Remove the insulation from the knockout holes.
3. For ease of installation, remove the nine (9) screws securing the top and remove the top.
4. Mount the remote display and run the display cable to the evaporator unit

Note: For every 90° bend in the ducting, the system loses 13 CFM of airflow.

Fan Speed Switch

The cooling system comes equipped with a variable fan speed switch. Increasing the fan speed increases the volume of cool air blown from the system. It is set by the factory to MED. To access the fan speed switch it is necessary to remove the front grille.

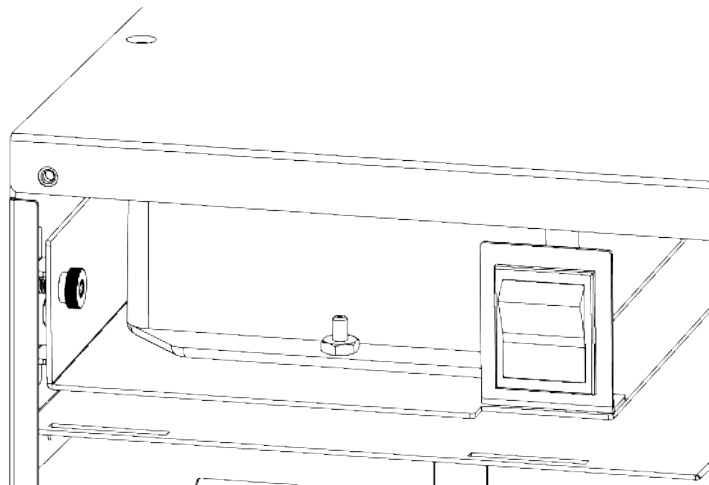

INSTALLING THE FULLY DUCTED EVAPORATOR

1. Using $\frac{1}{4}$ " and $\frac{1}{2}$ " copper tubing, route the liquid and suction lines through the knockouts in the housing. Be sure to extend the tubing far enough outside of the housing to extend through the wall if necessary. **NOTE:** $\frac{1}{2}$ " copper tubing will slip over the $\frac{3}{8}$ " suction line on the evaporator for an easy connection.
2. Remove the solenoid coil and wrap the solenoid valve in a wet rag to prevent overheating.
3. To prevent oxidation, purge the system with nitrogen.
4. Braze the copper tubing to the connections on the evaporator unit.
5. Insulate the suction line using Armaflex or similar insulation.
6. Using the cable ties and cable tie mounts provided, secure the drain line to the bottom of the housing to ensure a downward slope.
7. Route the power wire, display cable, and the bottle connector through the knockouts.
8. Remove the wire nuts from the black, white, and green wires located in the lower left corner of the evaporator unit.
9. Connect the green wire to the green wire, the black wire to the black wire, and the white wire to the white wire.
10. Install the supplied black strain relief to secure the power supply wires and bottle probe wire in the housing.
11. Connect the display cable labeled "UNIT" to the wire labeled "UNIT" located in the bottom of the evaporator compartment.A diagram showing a grey cable with a connector labeled 'UNIT' being inserted into a grey wire with a connector labeled 'UNIT'. An arrow points from the wire towards the cable.
12. Secure all wiring neatly and as close to the left wall as possible in order to minimize airflow obstruction.
13. Attach the supplied bottle probe to the circular connector on the bottom of the electrical panel. (See Figure 1.) Follow the directions on page 19 for correct installation and placement of the bottle probe.
14. Seal the air gaps around the display cable, bottle probe cable, and power wire knockouts by installing the supplied three-inch pieces of cork tape. (For best results, install the cork tape inside of the unit.)

Figure 1



INSTALLING THE FULLY-DUCTED EVAPORATOR UNIT

1. Route the liquid and suction lines through the knockouts in the housing.
2. Connect line set flare fittings to unit line set fittings.
3. Insulate the suction line using Armaflex or similar insulation.
4. Using the cable ties and cable tie mounts provided, secure the drain line to the bottom of the housing to ensure a downward slope.
5. Route the power wire, display cable, and the bottle connector through the knockouts.
6. Connect the green wire to the green wire, the black wire to the black wire, and the white wire to the white wire.
7. Install the supplied black strain relief to secure the power supply wires and bottle probe wire in the housing.
8. Connect the display cable labeled "UNIT" to the wire labeled "UNIT" located in the bottom of the evaporator compartment.

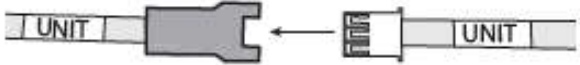
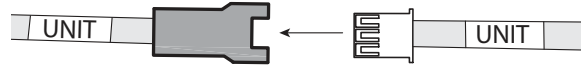

9. Secure all wiring neatly and as close to the left wall as possible in order to minimize airflow obstruction.
10. Attach the supplied bottle probe to the circular connector located on the small bracket mounted to the side wall in the evaporator compartment.

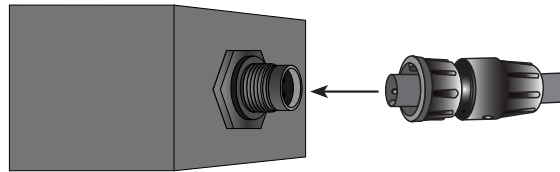

11. Seal the air gaps around the display cable, bottle probe cable, and power wire knockouts by installing the supplied three inch pieces of cork tape. (For best results, install the cork tape inside of the unit.)

CONNECTING THE LINESET

Connect the refrigerant piping according to these instructions.

1. Cut the pipes

When cutting the pipes be very cautious to cut and flare them properly. This will ensure a proper connection and minimize the need for maintenance.

1. Measure the distance between the indoor and outdoor units.
2. Using a pipe cutter, cut the pipe. Cut just below your measured distance.
3. Make sure that the pipe is cut at a perfect 90° angle. Refer to the example.

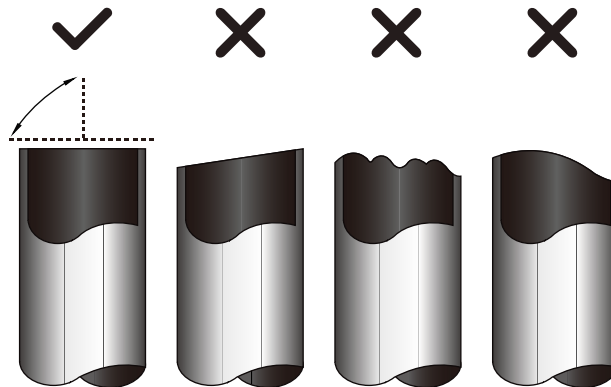

2. Remove Burrs

Burrs can affect the air tight seal of refrigerant piping connection. They must be completely removed.

1. Hold the pipe at a downward angle to prevent burrs from falling into the pipe.
2. Using a reamer or deburring tool to remove all burrs from the cut section of the pipe.

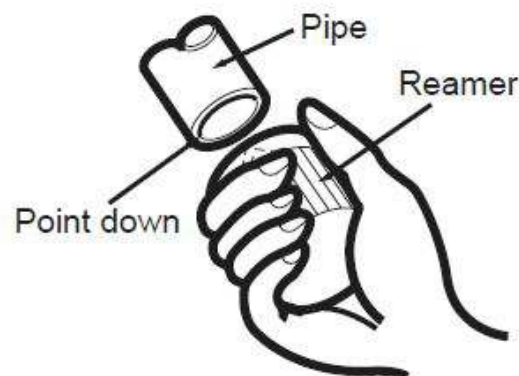

3. Flare Pipe Ends

Proper flaring is essential to achieve an airtight seal.

1. After Removing burrs from cut pipe, seal the ends with PVC tape to prevent foreign materials from entering the pipe.
2. Sheath the pipe with insulating material.
3. Place flare nuts on both ends of pipe. (Flare nuts provided with lineset.) Make sure they are facing the right direction. After flaring the pipe the nuts will not be removable. Remove PVC tape ends of pipe when ready to perform flare work.
4. Clamp flare form on end of pipe must extend beyond the edge of the flare form in accordance with the dimensions in the table (next page).
5. Place flaring tool onto form.
6. Turn the handle of the flaring tool clockwise until the pipe is fully flared.
7. Remove the flaring tool and flare form, then inspect the ends for any cracks and make sure the flaring is even.

CONNECTING THE LINESET, CONTINUED

PIPING EXTENSION BEYOND FLARE FORM

Outer Diameter of Pipe (in.)	A (in.)	
	Min.	Max.
1/4"	0.0275"	0.05"
3/8"	0.04"	0.063"
1/2"	0.04"	0.07"
5/8"	0.078"	0.086"
3/4"	0.078"	0.094"

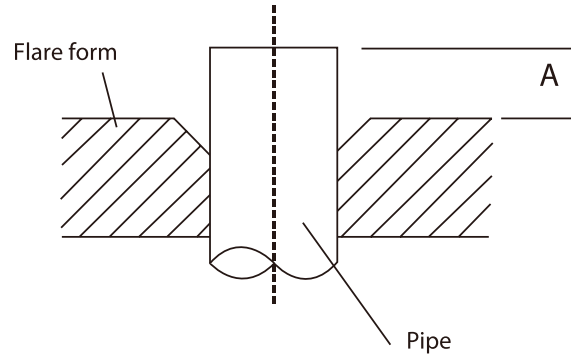

1. Cut the pipes

When connecting refrigerant pipes, be careful not to use any excessive torque or to deform the piping. You should first connect the low pressure pipe, then the high pressure pipe. It is recommended to use a CFC and HCFC compatible thread sealant on all threaded pipe connections.

1. Align the center of the two pipes that will be connected. To prevent gas leakage, apply refrigeration oil only to the inner surface of the flare. Use torque wrenches when tightening the flare nuts to prevent damage to the flare nuts and gas leakage.
2. Tighten the flare nut as tight as possible by hand.
3. Using a spanner, grip the nut on the unit tubing.
4. While firmly gripping the nut on the unit tubing, use a torque wrench to tighten the flare nut according to the torque values in the torque requirements table (**below**). Loosen the flaring nut slightly, then tighten again. Prior to applying recommended torque to brass flare nut, it is highly recommended that a small amount of refrigeration oil be applied to the flare threads, flare sealing surface, and copper tubing flared surface. This will prevent galling of sealing surfaces and aid in providing a refrigerant tight seal (Use refrigeration oil for R134a). Be careful not to overtighten the connection, as this may damage the flare or fitting.

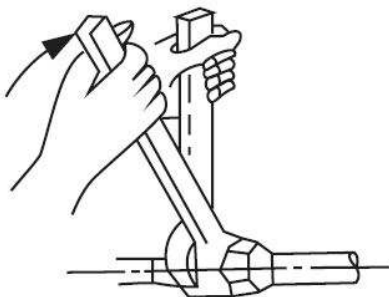
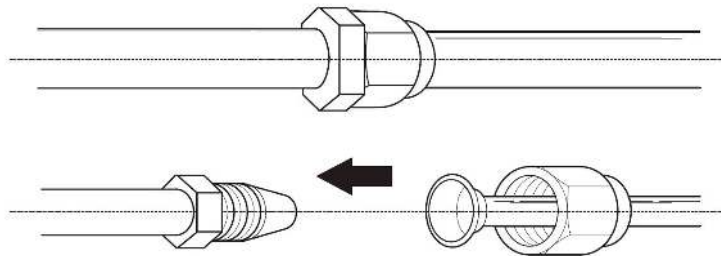

TORQUE REQUIREMENTS

Outer Diameter of Pipe (in.)	Tightening Torque (lb/ft)
1/4"	11 lb/ft
3/8"	18.4 lb/ft
1/2"	25.8 lb/ft
5/8"	33.19 lb/ft
3/4"	47.94 lb/ft

DUCTING OVERVIEW

Use ductwork to connect the unit to the supply and return outlets in the wine cellar. Use only insulated ductwork to minimize cooling losses, prevent sweating, and reduce noise. Use ductwork on the condenser section to redirect or absorb sound, bring in outside air to the unit inlet, and/or exhaust the hot air.

Note: Do not exceed a total of 12.5 feet for each length of ductwork run and a combined total of 25 feet for both the supply and return lengths.

Avoid crimping the flexible ducts. This reduces airflow, causing the unit to operate improperly. Be sure all ductwork and outer surfaces in contact with the airflow are insulated and have a vapor barrier on the outside. Uninsulated supply and return ducts may cause bare, exposed metal surfaces to sweat, further degrading the insulation and equipment cooling capacity.



Do not allow sharp turns to squeeze or decrease the inside diameter of the flexible ducting.



General duct recommendations:

- Provide support for the flexible duct to prevent sags and bends.
- Platinum Split duct size: 8" supply and 10" return
- Stretch out the duct to make a smoother interior which reduces air resistance.
- Maximum duct length is 25 feet per evaporator unit.
- For 90° bends, use a 90° adjustable elbow.
- No more than two 90° bends on each duct. Sweep 90° bends are recommended rather than sharp 90° bends.

NOTE: For every 90° bend, the system loses 13 CFM of airflow.

NOTE: A 12" x 12" return air filter grille must be installed to prevent contaminants from entering the cooling system. Supply

- duct must be insulated so it does not sweat or pick up heat.
- Generously apply duct sealant to all metal seams to fill in gaps that can leak air. Allow sealant to dry until firm to the touch
- before applying fiberglass insulation.
- Do not squeeze or reduce the inside diameter of the ducts, as this will reduce airflow.
- Use short and straight ductwork where possible.
- Check that all fan blades move freely.
- Keep air paths free of loose foreign objects and debris.
- To provide adequate airflow the fan speed must be set to high when the unit is ducted.
- Locate the supply and return grilles inside the cellar to create an airflow pattern that maximizes air circulation in the room.
- Avoid short circulation of the air.
- If the unit is installed through the wall, it must be mounted no more than 18 inches from the wine cellar ceiling. If the unit is
- ducted, the cold air supply duct must be installed no more than 18 inches from the wine cellar ceiling.

DO NOT:

Install through-the-wall return air grilles at floor level where they will collect dust from the floor. Locate the supply or return air grille where it is blocked by bottles, boxes, or cases.

DUCTING CONFIGURATIONS

There are a variety of ways to duct this unit. Please review the different configurations to determine a basis for your particular installation. Remember to contact a wine cellar professional if you have any questions.

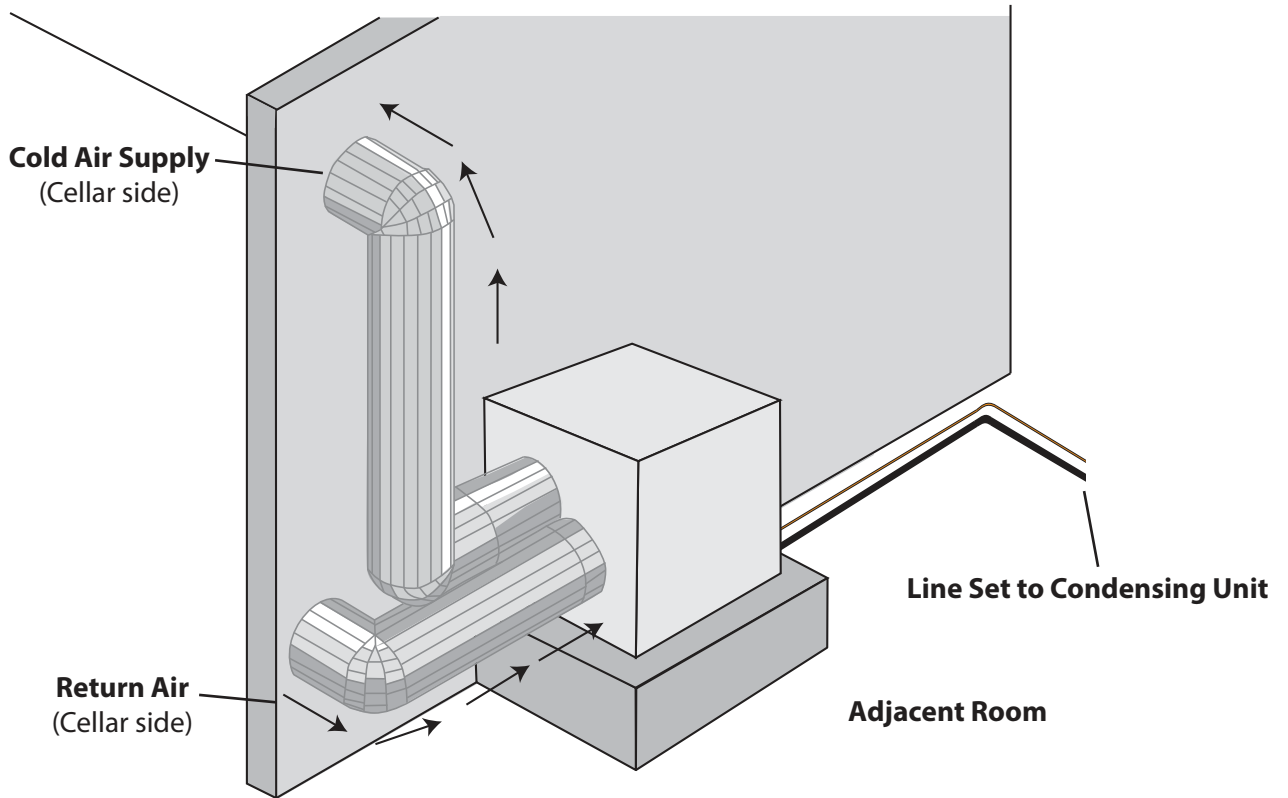

Attic Mounted Unit

It is required to use a secondary drip tray to prevent water damage. NOT supplied by WhisperKool.

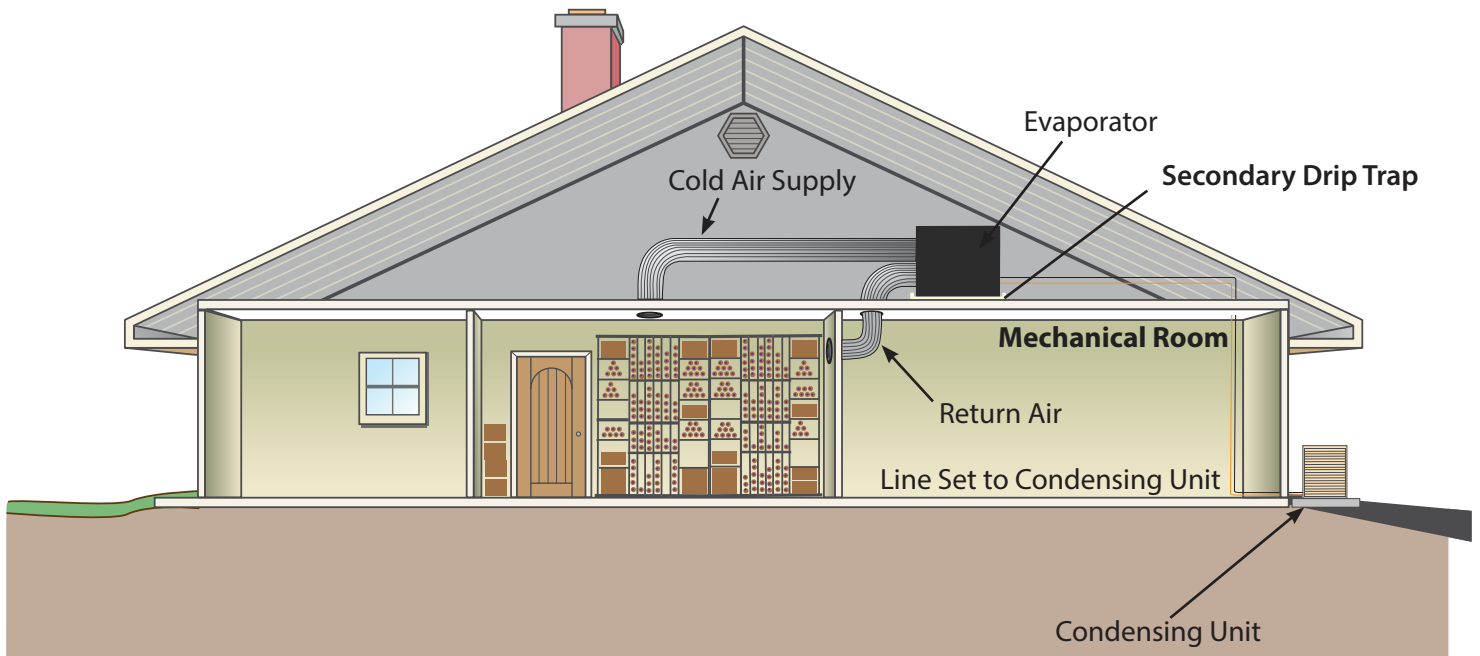

DRAIN LINE

Condensation Drain Line (not provided, but required)

The condensation drain line tube moves excess condensation from the evaporator unit to a proper discharge location. It is important for the drain line tube to be properly connected in order to prevent leakage and other problems associated with excess condensation

Failure to use the condensation drain line tube will void the warranty on the unit.

Drain Line

All systems come with a drain line connection tee and two 90-degree fittings. The unit is equipped with a ½" OD barbed fitting coming from the drip tray. (**NOTE:** ½" ID clear PVC tubing will need to be purchased and installed by the installing technician.) Installation of the drain line is mandatory, whether it leads through the wall and out of the cellar or remains inside the cellar. During operation, the cooling system will strip excess water from the air in order to maintain the proper level of humidity within the cellar. However, in extreme humidity, additional condensate will be removed; thus the drain line will prevent overflow and leakage by discharging the excess condensate.

Routing the tubing out of the unit:

Cut a small piece of ½" tubing and connect one end to the drip tray port and the other to a 90-degree fitting. (This will direct the tubing toward the back of the unit where the tube will exit the unit.) Be sure to extend the tubing far enough outside the housing to extend through the wall if necessary.

If routing out of the rear: Cut a piece of tubing long enough to protrude out of the knockout in the back side of the unit.

If routing out of the bottom: Cut a piece of tubing long enough to reach the knockout in the bottom of the unit and install the supplied 90-degree fitting. (This will direct the tubing out of the bottom of the unit without the risk of kinking the tubing.) **DO NOT USE TEE WHEN ROUTING OUT OF THE BOTTOM.**

Routing to discharge location if routed out of the bottom:

Connect the drain line directly to the second 90-degree barb fitting previously installed. Route the drain line to an appropriate drain location. No tee is required if draining through the bottom of the unit.



WRONG: Drain line is under water.

Routing to discharge location if routed out of the rear:

Insert the middle barb of the barbed tee fitting into the end of the drain line coming from the evaporator. Rotate fitting so tee is in the orientation shown in the diagram below. Connect a 3-inch piece of ½" drain line to the barb on top. Connect the remaining "long" piece of drain tubing to the bottom barb of the tee. Route the drain line to an appropriate drain location.

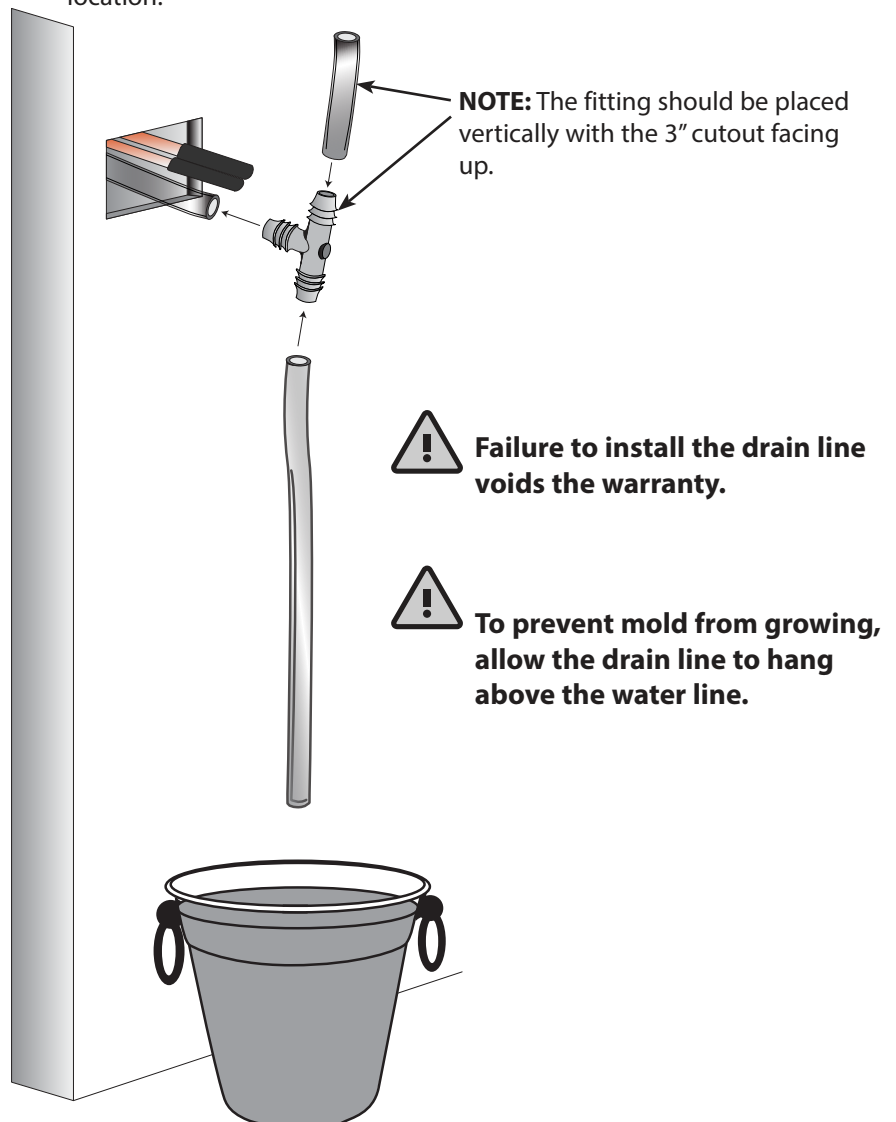

LIQUID-MEASURING THERMOSTAT SYSTEM (BOTTLE PROBE)

WhisperKOOL cooling units come with a liquid-temperature-measuring thermostat. The self-calibrating probe contains a sensor chip, which communicates back and forth with the thermostat. This results in a consistent temperature setting and accuracy. Wine should be kept at a very precise, controlled temperature and humidity. By measuring the liquid temperature rather than air, the unit will operate 75–80% of the time.

Setting up the Bottle Probe:

1. Locate an empty wine bottle.
2. Fill it 75% full with room-temperature tap water.
3. Place bottle probe securely into bottle as seen in Figure 1.
4. Place the wine bottle in your wine cellar. Ensure sensor tip is fully submerged.
5. To ensure a consistent temperature, place bottle probe approximately three (3) feet away from the air output and not in the flow of the air.

It is recommended that the bottle be placed in a central location of your wine cellar. Avoid pulling too much on the probe cord. It may become disconnected resulting in limited functionality of the unit.

Note: The thermostat can be set between 50–70°F.

Remember: The unit operates based on the temperature of the water. Do not be misled by thermostats reading air temperature. The air temperature in the cellar will be cooler than the liquid temperature of the wine while it is reaching the optimum balanced temperature.

Figure 1

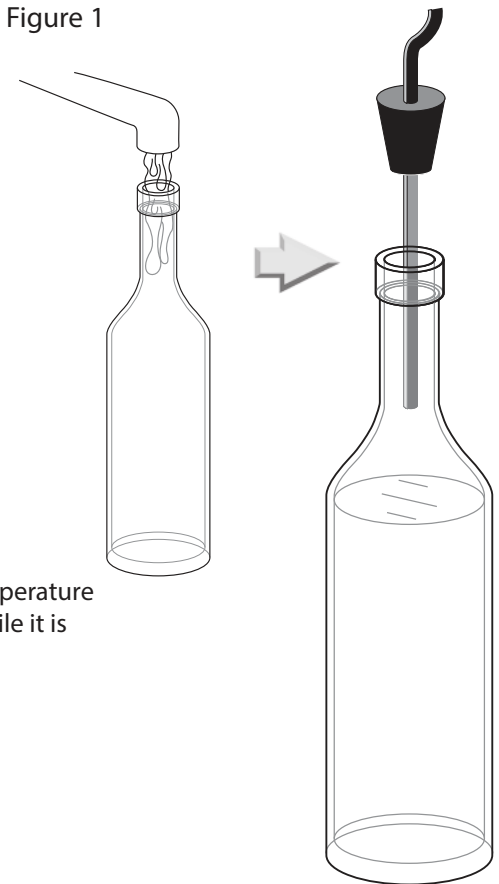

REMOTE DISPLAY: INSTALLATION AND CONFIGURATION*

Tools needed: 5/16" drill bit, 3/16" drill bit, drywall saw, level, pencil

What's included: Display panel, wall mount bracket, flush mount bracket, flush mount template



Display panel

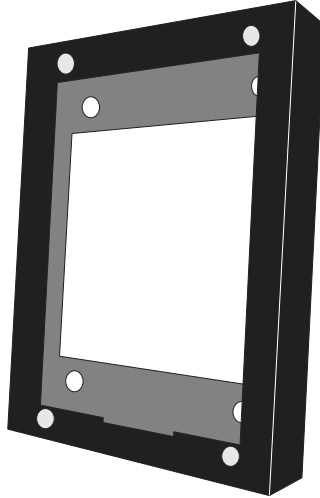

Wall mount bracket

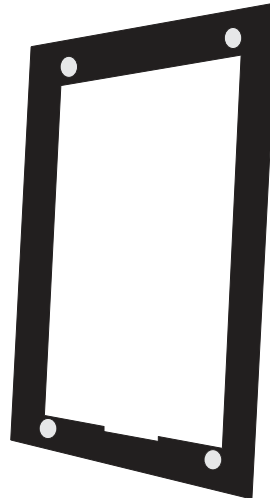

Flush mount bracket

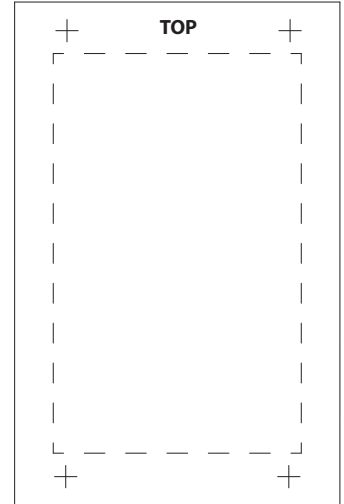

Flush mount template

Wall Mount Bracket Installation

1. Place the bracket on the wall. Use a level to ensure that the bracket is level. Using a pencil, mark the four screw holes in the rear of the bracket.

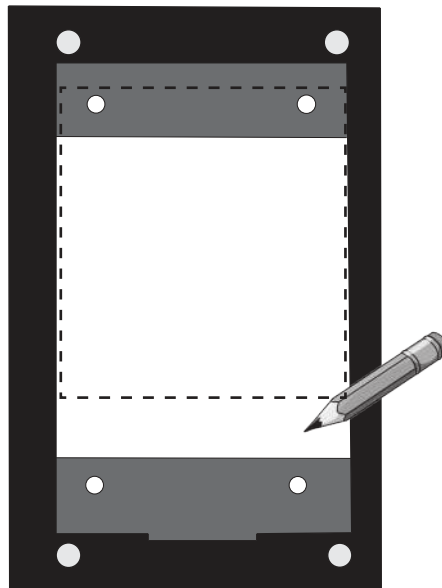

NOTE: Cut hole in the location shown for routing the display cable.

* The display can be mounted on any wall (inside or outside the wine cellar), up to 50 feet from the cooling unit.

WALL MOUNT BRACKET INSTALLATION, CONTINUED

- Using a drill with a $\frac{3}{16}$ " bit, drill four holes in the drywall for the screws. Insert the four (4) provided drywall anchors into the drywall, then tap them in with a hammer until they are flush with the wall.

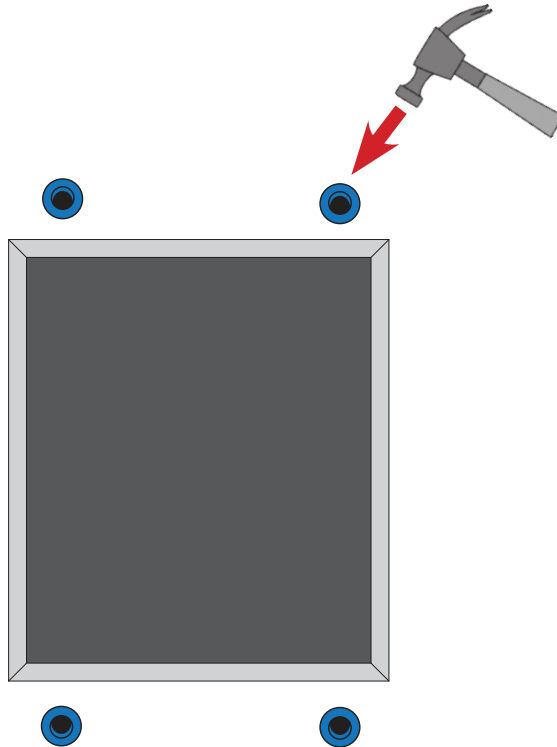

- Place bracket against wall, aligning screw holes with drywall anchors. Insert the four supplied Phillips-head screws into the drywall anchors. Tighten the screws to secure the bracket to the wall.

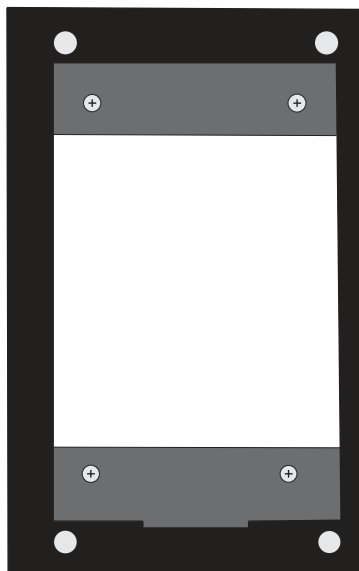

WALL MOUNT BRACKET INSTALLATION, CONTINUED

NOTE: Before you continue to Step 4, locate the area where the display will be mounted. You may route the display wire into the housing one of three ways: either through the wall or through one of the holes on the top or bottom edges of the wall mount bracket. If you'd like to route the display cable through one of these holes, place a rubber grommet into the hole and then route the display cable through the grommet and into the wall mount bracket.

4. Connect the end of the display cable labeled "DISPLAY" to the JST connector on the back of the display.

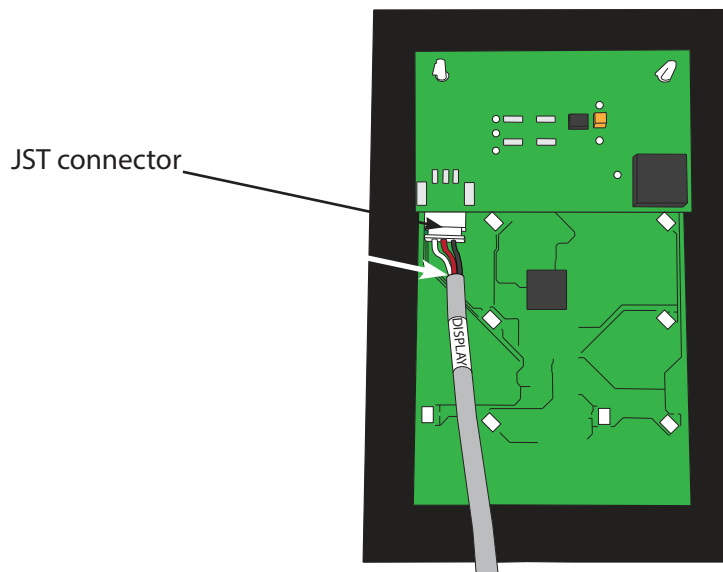

5. Place the display on the wall mount bracket as shown, attaching the back of the display panel to the magnets on the mounting bracket. Make sure that the alignment tab on the back of the display panel sits in the notch on the bottom of the bracket.

FLUSH MOUNT BRACKET INSTALLATION

Flush Mount Bracket Installation

1. Square the flush mount template on the wall using a level. Then draw a 3" line along the bottom edge of the template.
2. Peel the backing off the template and stick it to the wall, aligning the bottom edge with the line drawn in Step 1.

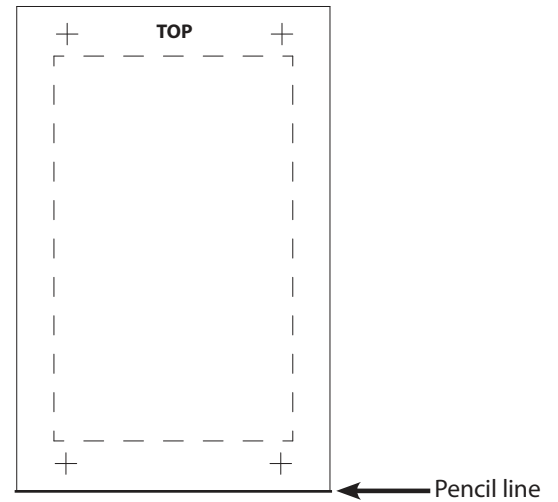
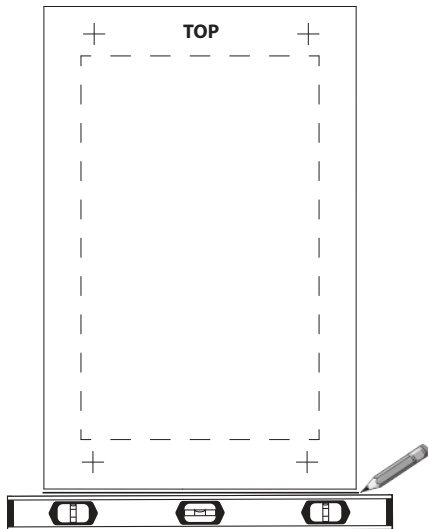

3. Use a 5/16" drill bit to drill a hole in the center of each cross (+).
4. Cut along the perforated lines. When finished, remove template from wall.

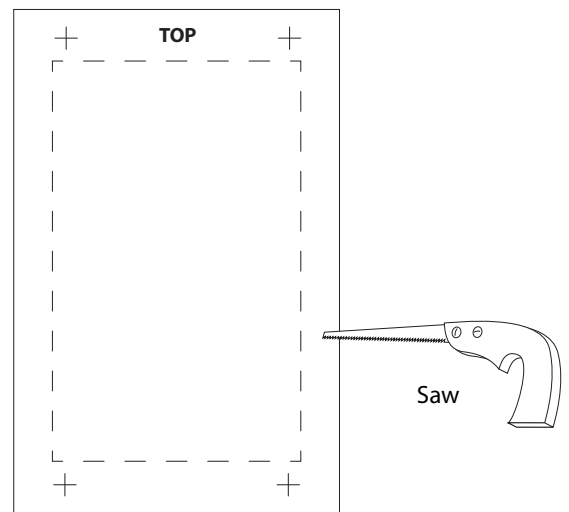
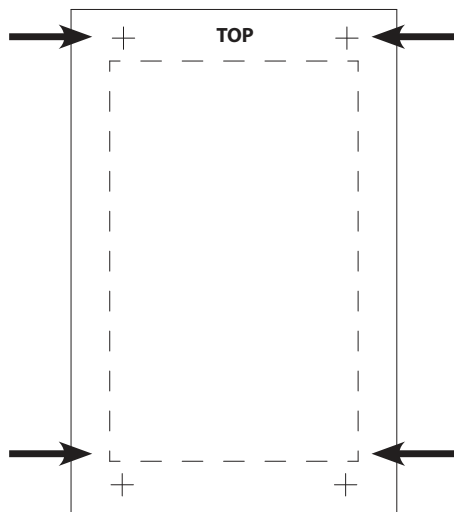

FLUSH MOUNT BRACKET INSTALLATION, CONTINUED

5. Remove the backing from the double-sided tape on the flush mount bracket.

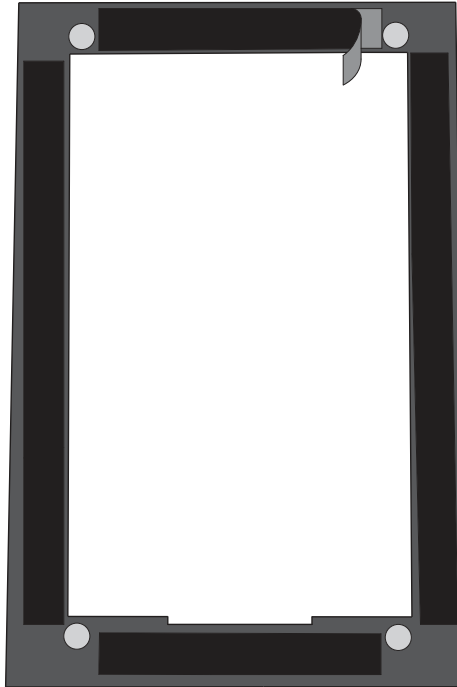

6. Align magnets with previously drilled holes. Make sure the cut-out portion of the bracket (circled below) is on the bottom. Press the bracket firmly against the wall.

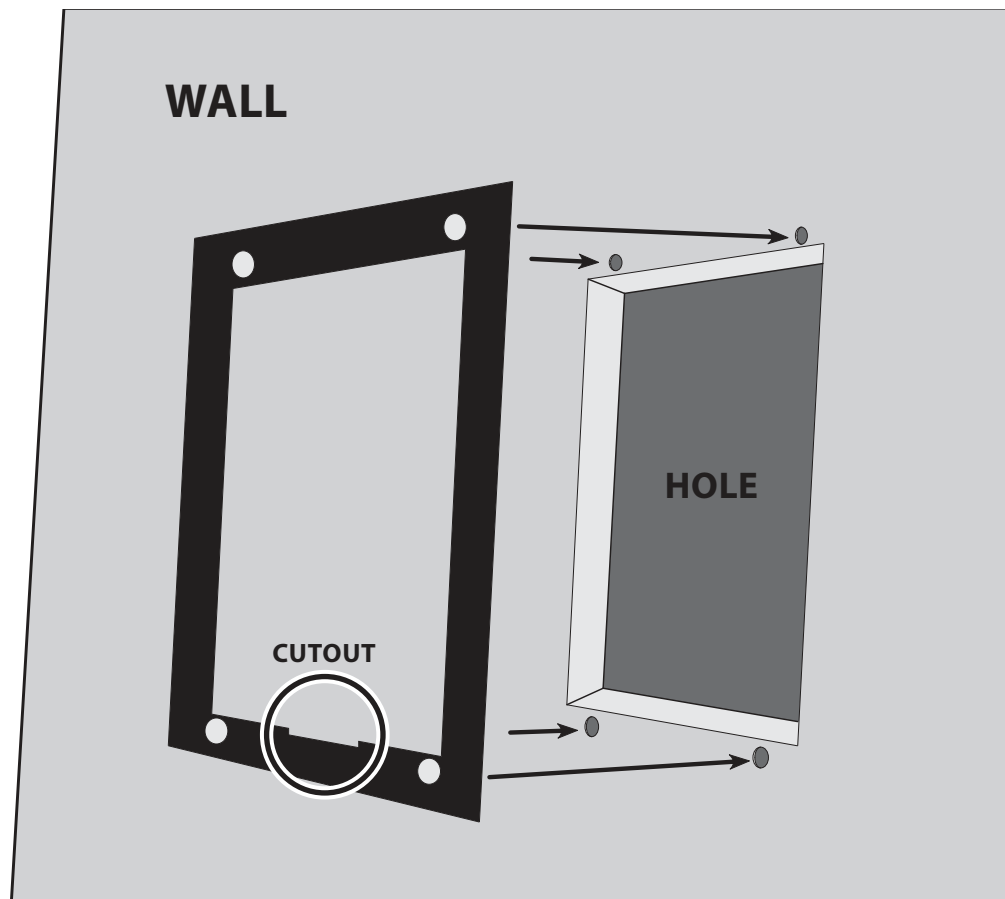

FLUSH MOUNT BRACKET INSTALLATION, CONTINUED

7. Connect the end of the display cable to the JST connector on the display panel.

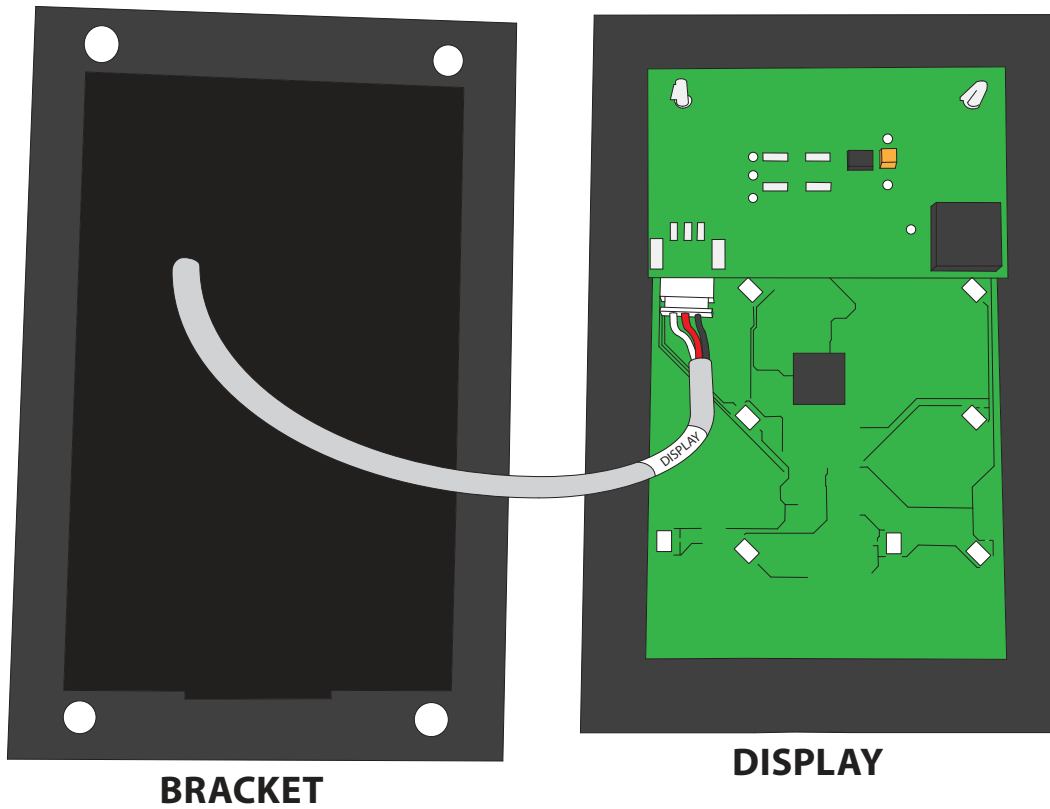

8. Place the display on the flush mount bracket as shown, attaching the back of the display panel to the magnets on the mounting bracket. Make sure that the alignment tab on the back of the display panel sits in the notch on the bottom of the bracket.

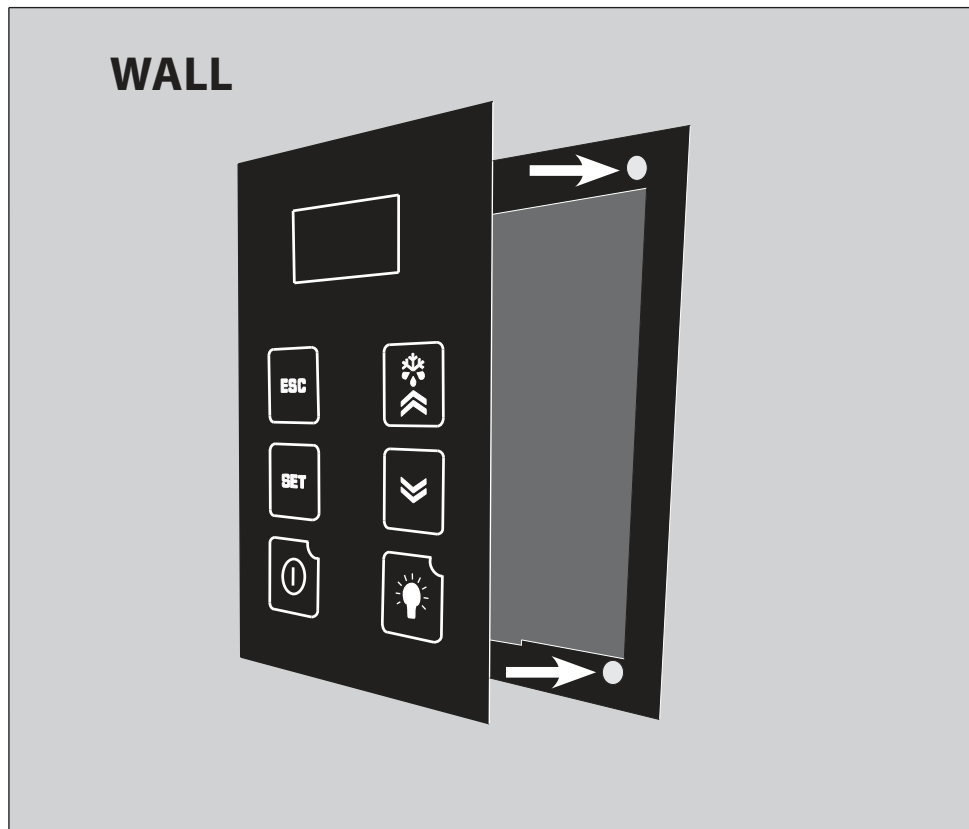

EVAPORATOR UNIT WIRING DIAGRAM (KDT)

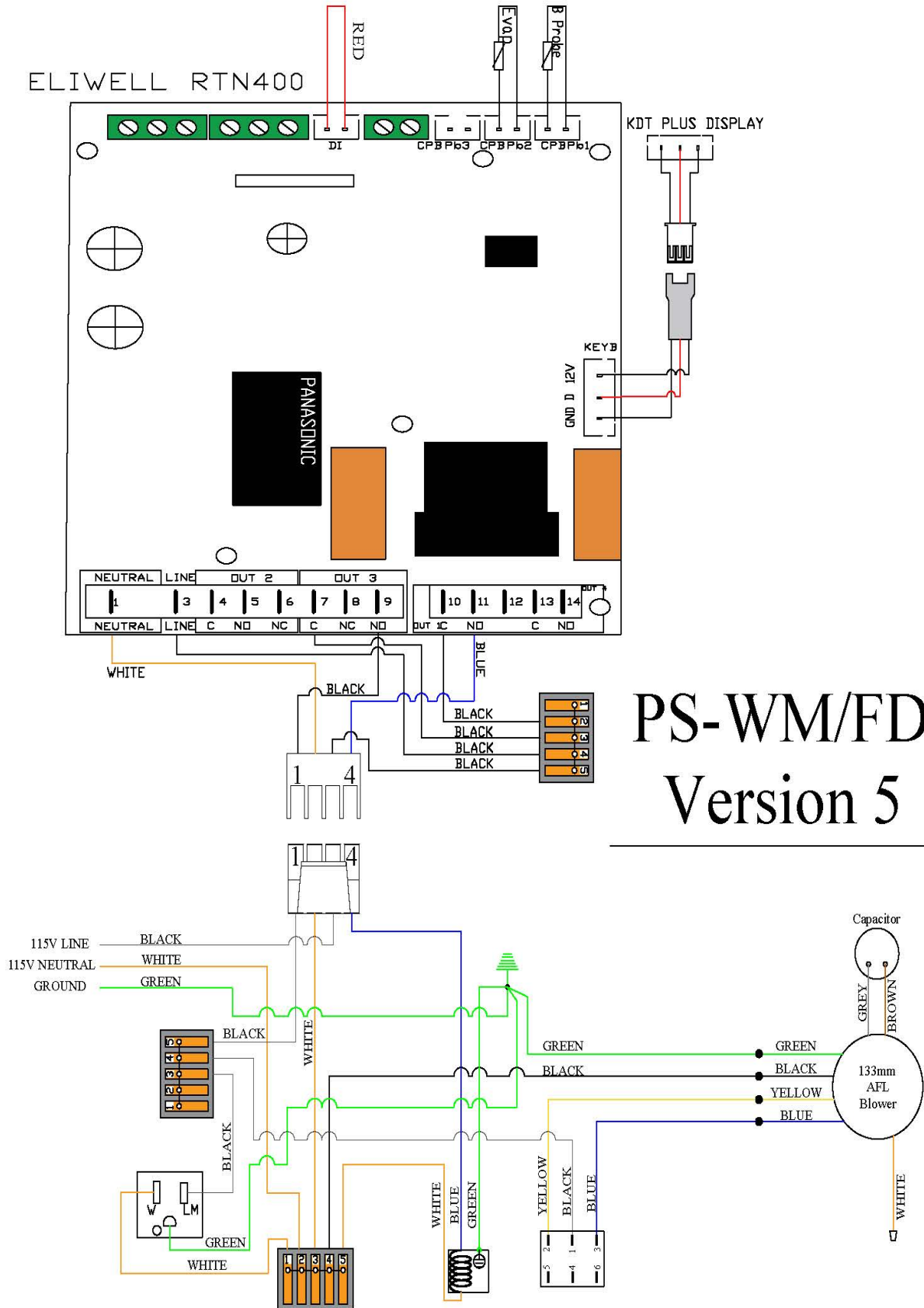

OMEGA CONDENSER

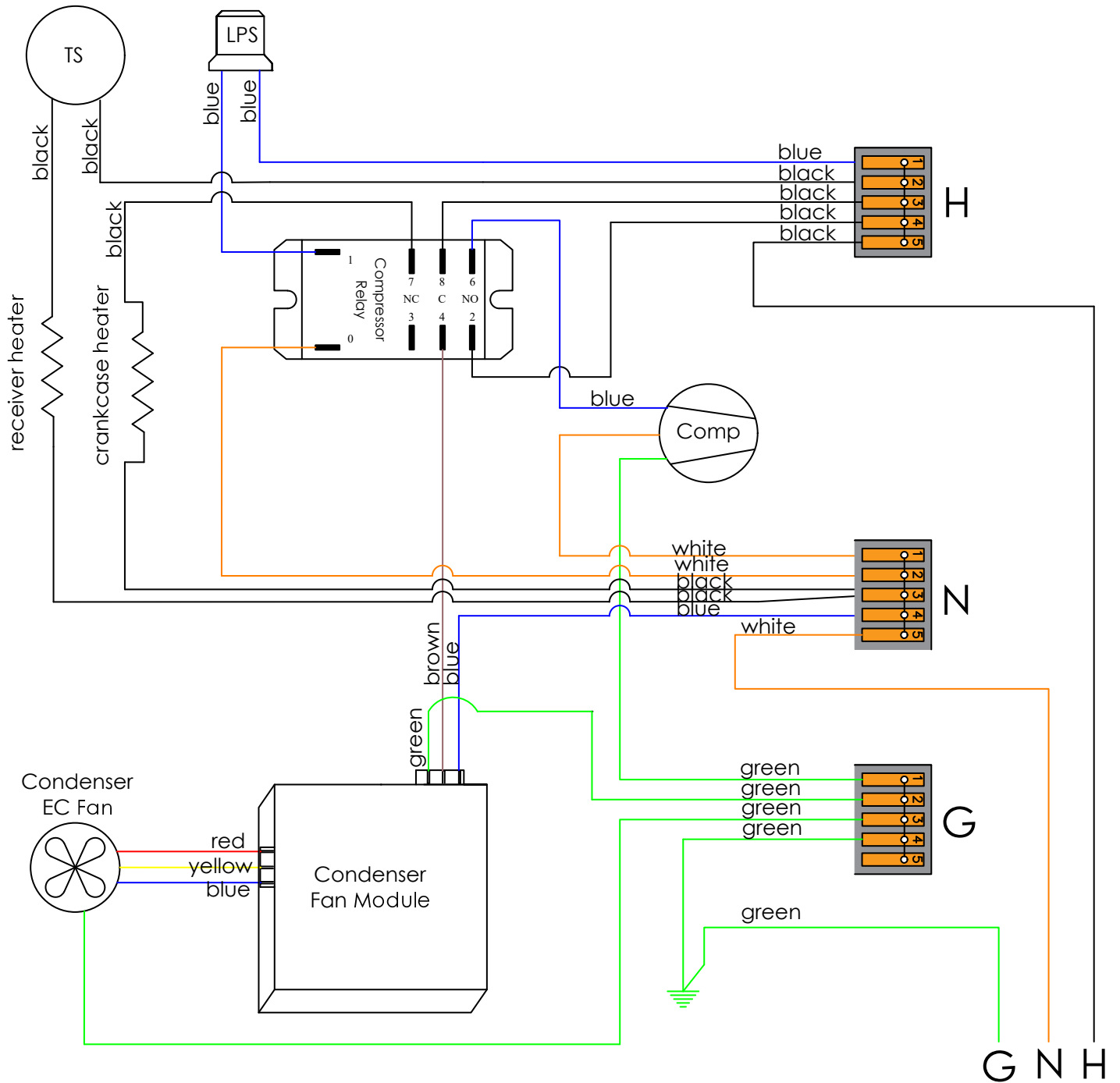

PREPARING THE CONDENSING UNIT

The Mini Omega condensing unit requires a dedicated 115V, 15-amp circuit.

The 4000 Omega condensing unit requires a dedicated 115V, 15-amp circuit.

The 8000 Omega condensing unit requires a dedicated 115V, 20-amp circuit.

The unit draws a large inrush current for about 1 second the instant the compressor starts. With a dedicated circuit and circuit breaker, the condensing unit will have sufficient power for effective operation. (The compressor is controlled by a low-pressure transducer mounted on the condensing unit. This feature eliminates the need for wiring between the evaporator unit/fan coil unit and the condensing unit.)

- Ensure the supplied voltage matches the rating specified on the unit spec label.
- Provide a non-GFI dedicated circuit and an appropriate outlet for the evaporator unit.
- Provide a dedicated circuit and circuit breaker for the condensing unit.
- Provide a weatherproof disconnect for the condensing unit if it is located outside.

Power surges and spikes can damage sensitive electrical equipment. WhisperKOOL recommends plugging the unit into a surge protector or power conditioner in order to protect your system. As outlined in our terms and conditions, power surges and spikes are not covered under warranty.

DO NOT USE A GROUND FAULT INTERRUPTER (GFI) WITH THIS PRODUCT.

In case the system should lose power, check the home/main circuit breaker. If the system does not respond properly, refer to the Troubleshooting Guide.

INSTALLING THE CONDENSING UNIT

These are two options for running the line set from the coil to the condensing unit. Option 1 is specifically applicable when the system is installed with the condensing unit below or leveled to the coil. Option 2 is applicable when the system is installed with the condensing unit at a higher elevation than the coil.

Option 1

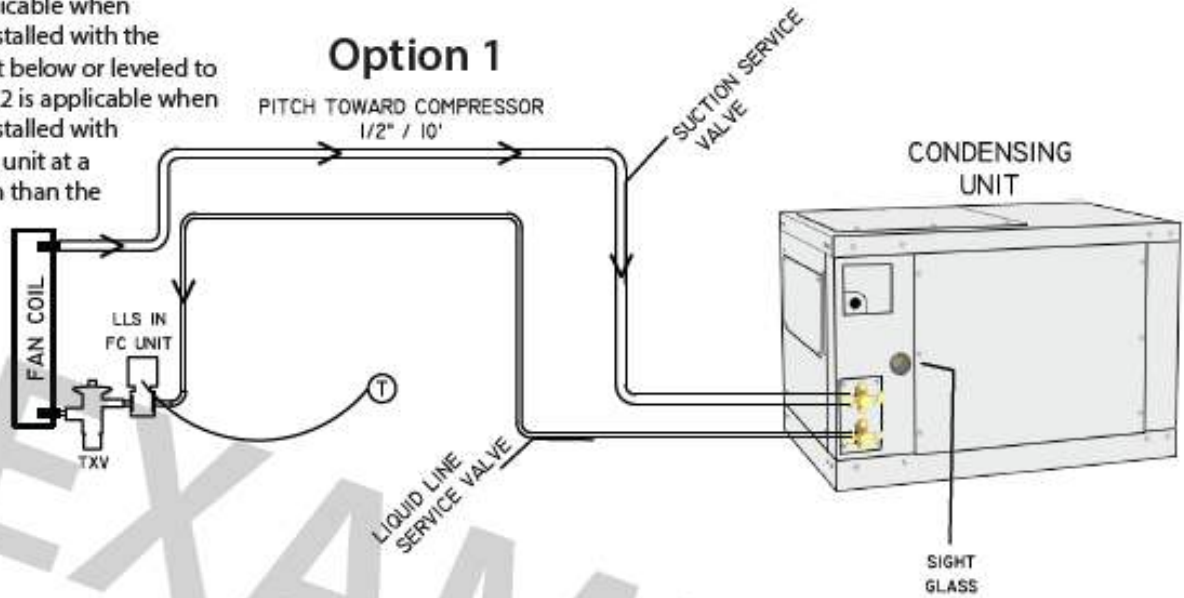

Option 2

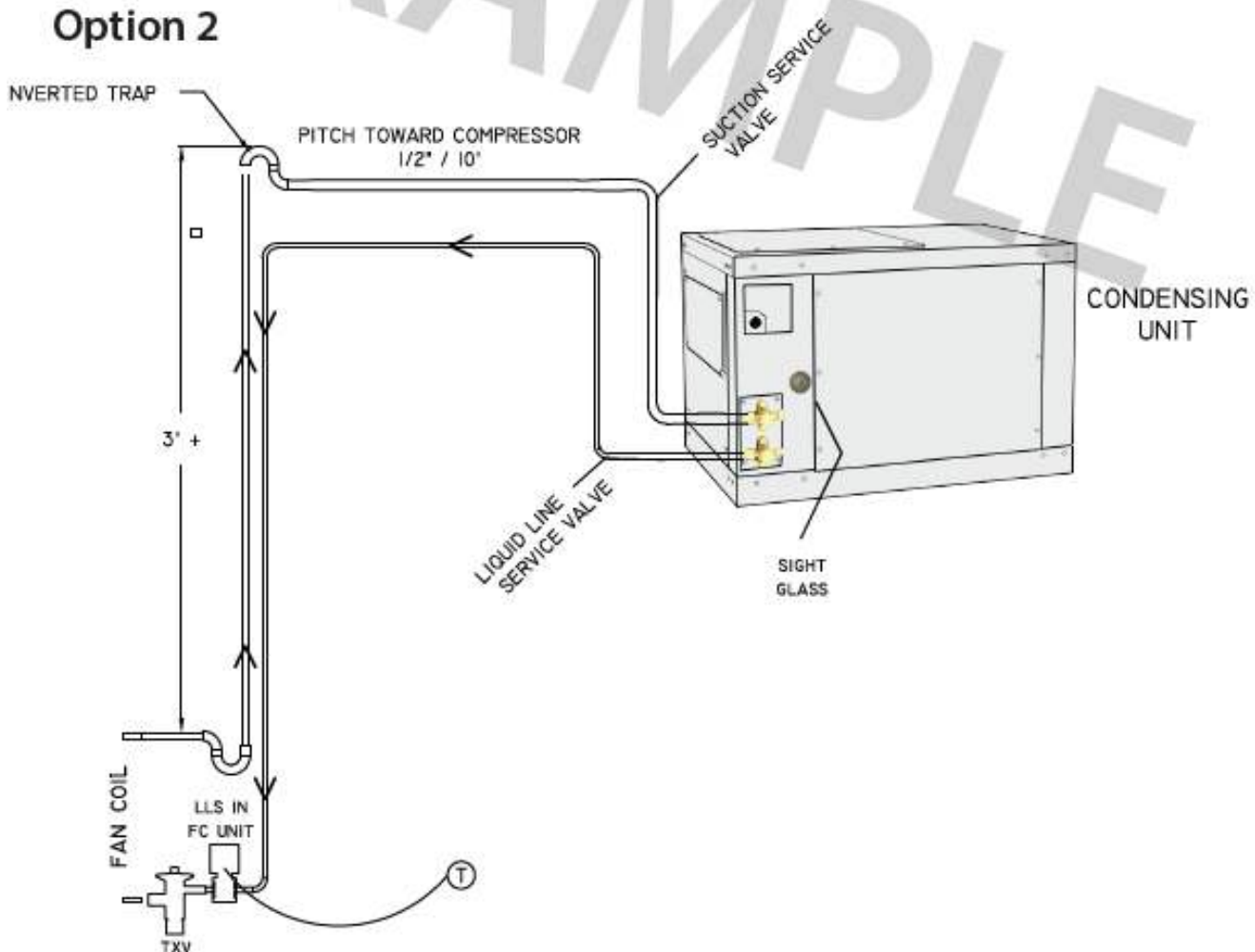

INSTALLING THE CONDENSING UNIT

The condensing unit can be installed inside a well-ventilated area of the home or mechanical room, but is typically installed outside. Exterior applications will require the use of a protective housing. The amount of sun exposure should be considered when selecting the placement of the condensing unit. The Mini and 4000 condensing unit requires a dedicated 15-amp circuit (non-GFI), and 8000 Omega condensing unit requires a dedicated 20-amp circuit (non-GFI). Ensure at least three (3) feet of horizontal clearance in every direction around the unit including if inside an exterior housing. The unit may either be hard-wired or plug-in, depending on local electrical codes.

Ensure that the condensing unit is level and has the proper amount of clearance outlined in the instructions. Also make sure you have the name plate power supplied, proper electric disconnect, and fuse protection connected but not turned on and ready for piping connections.

Outdoor condensing unit installations: You must utilize the exterior condensing unit housing for outdoor installations. Place the condensing unit on a solid foundation in a location with adequate ventilation. Make sure there is a minimum of three (3) feet of horizontal clearance in every direction around the unit including if inside an exterior housing. The unit should be elevated 18 inches in order to avoid damage

Refrigeration Lineset:

Omega 4000/8000	Line Set Length	<25 ft.	26-50 ft.	50-100 ft.
Suction Line	Horizontal Tubing	1/2"		5/8"
	Vertical Rise	1/2"		
Liquid Line	Vertical Rise	1/4"		

Omega Mini	Line Set Length	<25 ft.	26-50 ft.	50-100 ft.
Suction Line	Horizontal Tubing	3/8"		1/2"
	Vertical Rise	3/8"		
Liquid Line	Vertical Rise	1/4"		

Enclose the suction line with Armaflex (1/2" wall thickness) or comparable insulation to reduce heat transfer

INSTALLING THE CONDENSING UNIT

Refrigerant Piping Overview

- Using the charts and illustrations found above, route the line set between the evaporator unit and condensing unit. Be sure to reference the chart for correct line set sizing. All horizontal suction piping should be pitched toward the condensing unit half an inch for every 10 feet of pipe. When installing and routing the line set, cap both ends of each tube to prevent debris from entering the tubing.
- Prior to connecting the piping to the evaporator and condensing units, loosely connect a refrigerant manifold to the suction- and liquid line service valves.
 - Purge the hoses with dry nitrogen and tighten the hose connections.
 - Remove the service valve caps and turn the valve stem clockwise half a turn to unseat the valve and open the service port. Keep the piping ports sealed until ready to braze.
- Purge the fittings with dry nitrogen at a slow rate to prevent formation of highly abrasive copper oxide.
- Perform all brazes.
- Pressure test the system and check for leaks.
- Insulate the suction line using wall cellular insulation or equivalent. Seal all seams with Armaflex 520 Foam Insulation. Adhesive or equivalent. Wrap each seam using line set tape.

Liquid Line Piping Procedure

- Refer to the line set piping chart for liquid line size requirements.
- Braze a short piece of copper tubing to the liquid line service valve.
- Run the tubing to the evaporator unit and attach to the liquid line connection on the evaporator unit.

Suction Piping Procedure

- Connect an appropriately sized suction line to the suction line service valve on the condensing unit.
- Run the pre-insulated suction line to the evaporator unit and attach to the suction line connection on the evaporator unit.

Brazing Procedure

- Connect the bottle probe to the evaporator unit.
- Fill a wine bottle 75% full of room-temperature water. Insert the bottle probe into the neck of the bottle as far as possible. It is important that the bottle probe stopper be compressed by the neck of the bottle to ensure water will not leak.
- Energize the evaporator unit and set the controller to call for cooling.
- Verify that the setpoint on the control is set low enough to allow the unit to run for the entire length of the brazing, evacuation, and charging procedure.
- Remove the valve depressors from the gauge hoses on a four-valve manifold.
- Connect the manifold to the low-pressure service valve port on the condensing unit and a nitrogen tank.
- Open the suction line service valve and purge the system with nitrogen.
- Braze all connections and cool off quickly.
- Connect the high-pressure hose from the manifold to the liquid line service valve port.
- Pressure test the system at 150 psi for 20 minutes.
- Check all braze joints with leak detector or soap bubbles.
- Release the nitrogen once it is confirmed that there are no leaks.

Evacuation

- Remove the nitrogen tank from the manifold and attach the manifold to the refrigerant tank.
- Energize the liquid line solenoid valve.
- After confirming that there is fresh oil in the vacuum pump, connect the 3/8" hose from the manifold to the pump.
- Start the pump and run it until the micron gauge on the evaporator unit reads 500 microns or less.
- Disconnect the vacuum pump from the system.
- Break the vacuum by pressurizing the system to approximately 5 PSI with R-134a refrigerant.
- Remove the micron gauge from the access valve.

WhisperKOOL™

INSTALLING THE CONDENSING UNIT (continued)

Charging

- With the power off to the condensing unit, admit liquid refrigerant through the liquid line service valve until the refrigerant stops flowing.
- Turn on the circuit breaker for the condensing unit. The compressor should turn on if the pressure in the suction line is above 25 psi.
- Add refrigerant (in vapor form) to the low side of the system through the suction line service port.
- Observe the sight glass. If bubbles are present, add more refrigerant (in vapor form) to the low side.
- Once the sight glass is clear, check the superheat. Adjust the TXV until the superheat is between 16-30°F at the service valve. (refer to provided Charge Chart & TXV Adjustment)
- Under normal operation, with the wine cellar at 55°F and the ambient temperature at 85°F.

Finalizing the Installation

- Confirm that the entire suction line from the TXV to the suction line service valve is insulated using cellular insulation or equivalent. Seal all seams with Armaflex 520 Foam Insulation Adhesive or equivalent.
- Confirm that the control is displaying the correct temperature and that no alarms are present.

Charging Information

- A. Energize the solenoid valve on the evaporator unit by plugging the unit in and adjusting the thermostat to call for cooling.

WARNING! Allowing your unit to operate in high ambient temperatures for extended periods of time will greatly decrease the life of your unit and void your warranty.



Charge Chart & TXV Adjustment Ranges

Omega Mini

APPROXIMATE INITIAL CHARGE CHART

Line Set	Charge Total
10' Line Set	2.00 lbs
20' Line Set	2.15 lbs
30' Line Set	2.30 lbs
40' Line Set	2.45 lbs
50' Line Set	2.60 lbs
60' Line Set	2.75 lbs
70' Line Set	2.90 lbs
80' Line Set	3.05 lbs
90' Line Set	3.20 lbs
100' Line Set	3.35 lbs

Omega 4000/8000

APPROXIMATE INITIAL CHARGE CHART

Line Set	Charge Total
10' Line Set	2.50 lbs
20' Line Set	2.65 lbs
30' Line Set	2.80 lbs
40' Line Set	2.95 lbs
50' Line Set	3.10 lbs
60' Line Set	3.25 lbs
70' Line Set	3.40 lbs
80' Line Set	3.55 lbs
90' Line Set	3.70 lbs
100' Line Set	3.85 lbs

SUBCOOLING CHART

CELLAR TEMPERATURE

	50F	55F	60F	65F	70F	75F	80F	85F
40F & Under	3	3	4	4	5	5	6	6
45F	3	3	4	4	5	5	6	6
50F	3	3	4	4	5	5	6	6
55F	4	4	5	5	6	6	7	7
60F	4	4	5	5	6	6	7	7
65F	4	4	5	5	6	6	7	7
70F	5	5	6	6	7	7	8	8
75F	5	5	6	6	7	7	8	8
80F	5	5	6	6	7	7	8	8
85F	6	6	7	7	8	8	9	9
90F	6	6	7	7	8	8	9	9
95F	7	7	8	8	9	9	10	10
100F	7	7	8	8	9	9	10	10
105F	8	8	9	9	10	10	11	11
110F	8	8	9	9	10	10	12	12

OUTDOOR TEMPERATURE

SUPERHEAT CHART

CELLAR TEMPERATURE

	50F	55F	60F	65F	70F	75F	80F	85F
40F & Under	16	16	17	17	18	18	19	19
45F	16	17	17	18	18	19	19	20
50F	17	17	18	18	19	19	20	21
55F	17	18	18	19	19	20	21	22
60F	18	18	19	19	20	21	22	23
65F	18	19	19	20	21	22	23	24
70F	19	19	20	21	22	23	24	25
75F	19	20	21	22	23	24	25	26
80F	20	21	22	23	24	25	26	27
85F	21	22	23	24	25	26	27	28
90F	22	23	24	25	26	27	28	28
95F	23	24	25	26	27	28	28	29
100F	24	25	26	27	28	28	29	29
105F	25	26	27	28	28	29	29	30
110F	26	27	28	28	29	29	30	30

OUTDOOR TEMPERATURE

Subcooling: within shade range + or - 1F°

Superheat: within shade range + or - 2 F°

WhisperKOOL™

TXV ADJUSTMENT

The TXV is shipped from the factory preset for 50 Feet. A TXV adjustment may be necessary based on the ambient temperatures in the cellar and at the condensing unit.

Danfoss TXV Adjustment

Most units are equipped with a Danfoss adjustable TXV.

- Adjust the TXV until the total superheat measured at the suction (vapor/low pressure) line service valve is 8°F to 25°F. With the power off to the condensing unit, admit liquid refrigerant through the liquid line service valve.

To adjust the TXV use a 5/32" hex key to remove the cap from the TXV superheat adjustment port. (Figure 1)

1. With the cap removed, insert the hex key into the superheat adjustment port.
2. Increase superheat by turning clockwise.
3. Decrease superheat by turning counter-clockwise.

FIGURE 1

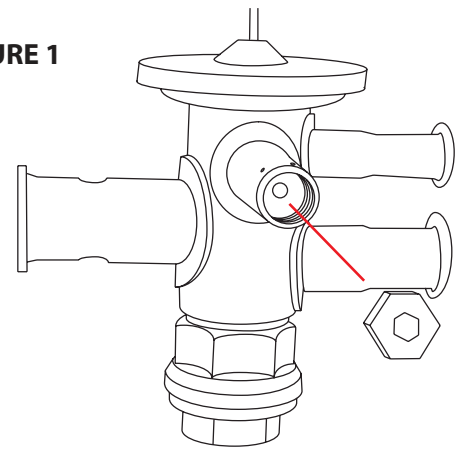

Sporlan TXV Adjustment

Some units are equipped with a Sporlan adjustable TXV.

Adjustment Steps:

1. Remove the seal cap using two wrenches. (Figure 2)
 - i. Use a 7/8" wrench on the BOTTOM cap.
 - ii. Use a 3/4" wrench on the TOP (seal) cap.
2. With the cap seal removed. (Figure 3)
 - i. Use a 3/16" service wrench to tighten or loosen the service stem located under the seal cap.
 - ii. When the adjustment is completed, replace the seal cap.

FIGURE 2



FIGURE 3

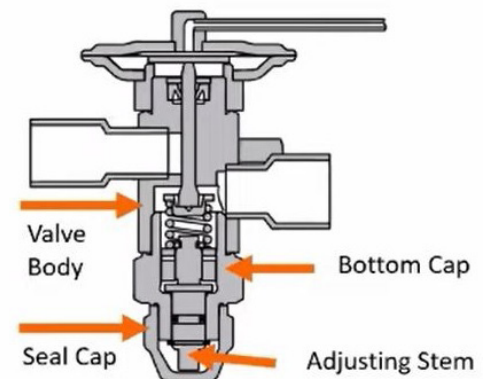

TXV ADJUSTMENT, CONTINUED

Sanhua TXV Adjustment

Some units are equipped with a Sanhua adjustable TXV.

Adjustment Steps:





1. Remove the seal cap using two wrenches. (Figure 2)
 - i. Use a wrench on the BOTTOM cap.
 - ii. Use a wrench on the TOP (seal) cap.
2. With the cap seal removed. (Figure 3)
 - i. Use a Flat Head to tighten or loosen the service stem located under the seal cap.
 - ii. When the adjustment is completed, secure the seal cap.

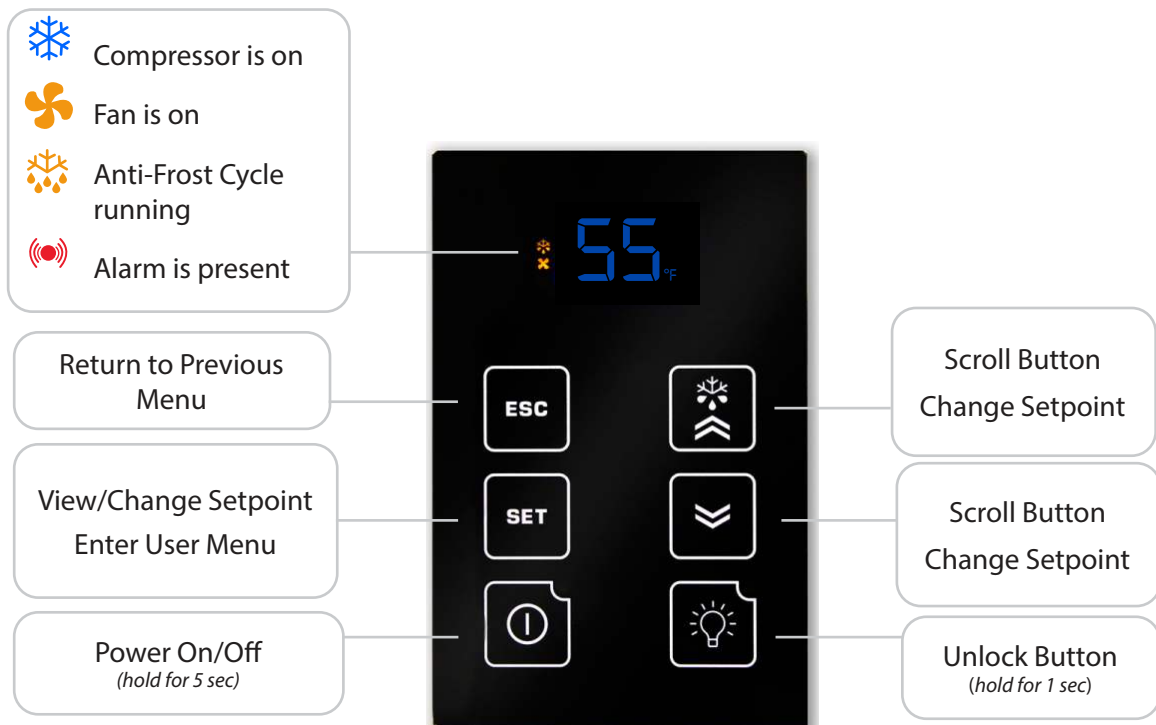





DISPLAY LAYOUT





CONTROLLER FUNCTIONS

Button	Normal Functions								
INITIAL STARTUP	When the unit is plugged in and power is sent to the controller, a beep will sound, confirming that the controller is getting power. All LEDs on the display will blink three times. Three dashes will then appear on the screen. All display LEDs will then blink three times. Once the controller has gone through the initial startup process, and all LEDs have cycled, the home screen will be displayed.								
UNLOCKING THE DISPLAY	Press and hold any button for one second to unlock the display. (A white LED will appear in the top left corner of the button being pressed.) A beep will sound, signifying that the display is unlocked. NOTE: The display must be unlocked before any button functions become available.								
ON/OFF 	To turn the unit ON, press and hold the ON/OFF button until the red LED turns OFF. To turn the unit OFF, press and hold the ON/OFF button until the red LED turns ON.								
UP/DOWN 	The up and down arrows are used to navigate through menus and adjust parameters such as setpoint, Fon/FOF, etc.								
SET 	<ul style="list-style-type: none"> To change the setpoint, press the SET button. When "SEt" is displayed on the screen, press the SET button once more. Use the UP and DOWN ARROW buttons in order to change the value until the desired setpoint is reached. The SET button allows you to view the setpoint, evaporator temperature, bottle temperature, alarms, and the hidden menu. Press the SET button once. "SEt" will be displayed. Press the UP or DOWN ARROW buttons to scroll through ALr, Pb1, or Pb2. <table border="1" data-bbox="467 1186 1511 1350"> <thead> <tr> <th>Set</th> <th>Setpoint</th> </tr> </thead> <tbody> <tr> <td>ALr</td> <td>Alarm folder</td> </tr> <tr> <td>Pb1</td> <td>Liquid (bottle probe) temperature</td> </tr> <tr> <td>Pb2</td> <td>Evaporator coil temperature</td> </tr> </tbody> </table> <ul style="list-style-type: none"> Press the SET button again to view any of these values. Hold the SET button for approximately 5 seconds to enter the User Menu. Other parameters in the User Menu which are not available for adjustment include: idF, rEL, and LAn. 	Set	Setpoint	ALr	Alarm folder	Pb1	Liquid (bottle probe) temperature	Pb2	Evaporator coil temperature
Set	Setpoint								
ALr	Alarm folder								
Pb1	Liquid (bottle probe) temperature								
Pb2	Evaporator coil temperature								
ESC 	This button confirms changes made to parameters such as the setpoint and returns you to the previous menu.								
LIGHT 	The light function is not in use. However, this button can still be used to unlock the display.								

ICON GLOSSARY

Icon	Meaning
SNOWFLAKE 	<p>Blinking: The unit is calling for cooling, but must wait five minutes before restarting the compressor. This five-minute delay serves as an Anti-Short Cycle for the compressor's protection.</p> <p>Constant: The unit is in cooling mode and the condensing unit is running.</p>
DRIPPING SNOWFLAKE 	<p>The unit is undergoing an Anti-Frost Cycle. While the Anti-Frost Cycle is running, "dEF" will be displayed on the screen. See System Operation page for further details.</p>
FAN 	<p>The evaporator fan is running.</p>
ALARM 	<p>The alarm icon is shown when the unit encounters an issue that needs attention. Alarm codes are explained on the following page. All temperature-related alarms are blocked for the first 10 hours after the unit is plugged in to allow the system to stabilize and acclimate to the new environment.</p>

WHISPERKOOL CONTROLLER ALARM CODES

Code	Cause	Solution
The following alarm codes will be displayed on the screen along with the alarm icon. 		
E1	Bottle probe is not connected	Attach bottle probe to circular connector
	Faulty bottle probe connection	Locate faulty bottle probe connection by inspecting all wiring connections between the bottle probe and the circuit board. The two-pin connector for the bottle probe should be connected to the CPB/PB1 terminal on the circuit board. If it is not connected, plug it in. If a faulty connection has been identified, correct the issue or contact customer service for further assistance. NOTE: The E1 code will not appear in the alarms menu. It will be permanently displayed on the screen.
	Defective bottle probe	Replace the bottle probe
E2	Faulty evaporator probe connection	Locate faulty evaporator probe connection by inspecting evaporator probe wire. The two-pin connector for the evaporator probe should be connected to the CPB/PB2 terminal on the circuit board. If it is not connected, plug it in.
	Defective evaporator probe	Replace the evaporator probe
E7	No communication between keypad and circuit board for 60 seconds	Verify that the display cable is connected to the keypad and the circuit board and is not damaged, frayed, or kinked. If problem persists, contact Customer Service for troubleshooting information.
E10	Clock battery is dead	Replace battery NOTE: A dead clock battery will not affect the operation of your cooling unit.
The following alarm codes will not be displayed on the home screen. However, the alarm icon will be displayed in the event of an alarm. The alarms can be viewed in the Set Menu's ALr folder. 		
EA	Unit is not draining properly	<ol style="list-style-type: none"> 1. Check to see that the unit is level; if not, level it 2. Verify that the drain line is not clogged; if so, clear obstruction 3. Ensure that the condensate pump is operating 4. Verify wire connection at D.I. port of circuit board NOTE: If the drain line is obstructed or the pump fails for some reason, and the water level in the drip tray gets too high, the unit will not operate until the water in the internal drip tray drops back below the proper level. NOTE: If the unit loses power (due to a power outage or being manually unplugged), the condensate pump may need to be reset. To do this, disconnect and reconnect the black cables on the condensate pump.
AH1	The bottle probe is sensing a temperature that is 4°F above the setpoint	<ol style="list-style-type: none"> 1. Allow time for the wine to reach the desired temperature 2. Ensure that the cellar is sealed properly 3. Verify that the bottle probe is calibrated correctly (refer to the User Menu on the following page) 4. Verify that the unit is sized correctly for the cellar
AL1	The bottle probe is sensing a temperature that is 4°F below the setpoint	<ol style="list-style-type: none"> 1. Make sure the unit is not in cooling mode (the snowflake icon will not be illuminated) 2. Add heat to the room until the wine reaches the desired temp 3. Verify that the bottle probe is calibrated correctly (refer to the User Menu on the following page)
Ad2	The Anti-Frost Cycle ended on time-out	<ol style="list-style-type: none"> 1. Check the evaporator coil for ice buildup. Unplug the unit and allow the coil to thaw before restarting. 2. Make sure the room to which the unit is exhausting is not below 60°F 3. If the unit repeatedly goes into Anti-Frost Cycles (one per minute), call Customer Service for more troubleshooting information

USER MENU

The User Menu is accessed by **pressing and holding the SET button for 3 seconds**. Use the UP and DOWN ARROW buttons to navigate to desired parameters. Press the SET button again to view these parameters. Press the UP and DOWN ARROW buttons to adjust a parameter.

The following parameters are available in the menu:

Parameter	Description
Fdc - humidity enhancement	This parameter is measured in minutes, and is preset at the factory to 1. An increase in this parameter will increase the humidity enhancement of your cellar. This parameter should not be adjusted to zero. Adjustments should be made in increments of 5, with a maximum of 15 and a minimum of 1. After making any adjustments to humidity enhancement, you should wait a minimum of 3 days before making any additional adjustments. This will allow sufficient time for the cellar to acclimate to the new setting.
FOF - "fan off"	This setting controls how long the fan stays off after the setpoint has been reached. It is preset to 15 minutes. This setting should not be adjusted, as most properly constructed wine cellars retain an ample amount of humidity during the "fan off" cycle. If, however, you wish to decrease the duration of the "fan off" cycle (in order to increase the wine cellar's relative humidity), you can adjust this setting in the User Menu.
Fon - "fan on"	The "fan on" time is preset to zero minutes. This keeps the relative humidity of the wine cellar at a stable level. If, however, you wish to raise the relative humidity of your wine cellar, you can increase the duration of the "fan on" cycle in increments of five (5, 10, or 15 minutes). After making any adjustment to the "fan on" cycle, you should wait a minimum of 3 days before making any additional adjustments. This will allow sufficient time for the cellar to acclimate to the new setting.
CA1 - bottle probe (Pb1) calibration	CA1 - bottle probe (Pb1) calibration: You may use this parameter to calibrate the bottle probe to a known temperature. This parameter can be adjusted between -12°F and 12°F. For example, if the bottle probe temperature is 58°F, and the known temperature is 55°F, you can set the CA1 parameter to -3°F to match the known temperature.
PA2 - installer menu	This menu is only accessible using a password and is not available for adjustment.
dOA - digital input	This setting determines which of the unit's components will be activated or deactivated when a certain electrical relay is activated or deactivated in response to an alarm. The controller comes pre-programmed with a factory setting of 2. 2 = activates the compressor and fans 5 = disables the compressor and fans NOTE: Setting the dOA to any number other than 2 or 5 will prevent the unit from operating properly.

WHISPERKOOL TROUBLESHOOTING GUIDE

Unit has ice forming on the evaporator unit	
Possible cause	Solution
Evaporator filter or coil is dirty	Remove the filter and wash it, then clean the coil with a vacuum. If coil is very dirty, use a spray bottle with a small amount of liquid dish detergent or coil cleaner. Spray coil, let set for five minutes, then flush with fresh water.
There is something blocking the supply and/or return air	Remove blockage
The evaporator fan is not turning on	Call a service tech to troubleshoot
The evaporator unit has not gone through an Anti-Frost Cycle yet	Check the coil for surface ice. Melt with blow drier until coil is warm to the touch. Soak up water with a towel.
If evaporator unit continues to ice	Observe ice formation pattern. If only part way up the coil face, the system could be low on refrigerant. If all the way up, the coil may be dirty or airflow is blocked.
Unit does not run/power up	
Possible cause	Solution
Evaporator Unit is not plugged in	Make sure the unit is plugged into an outlet
Power switch not on	Turn unit on by pressing the power button on the control
Line voltage rating is incorrect for the system	Check line voltage to make sure there is 110V-120V
Bottle at setpoint	Lower setpoint
Thermostat not calling for cooling	Lower setpoint
Faulty thermostat or wiring	Call Customer Service
Cellar temperature is too warm	
Possible cause	Solution
The temperature of the room to which the condensing unit exhausts exceeds 110°F	Intake temperature needs to drop below 110°F
The system is undersized for the cellar	Order correct size system
There is something blocking the supply and/or return air on the evaporator unit or the condensing unit	Remove air flow obstruction
Evaporator unit is mounted too low in the cellar	Relocate unit so the distance from the ceiling and top of the unit is no more than 18"
One or more of the fans is not turning on	Please contact the installing technician to troubleshoot
Compressor is not turning on	Please contact the installing technician to troubleshoot
Compressor keeps cycling on overload	Make sure all fans are working and there is no airflow obstruction
Poor seal around door or other areas requiring a seal (around the unit, wall joints, etc.)	Make sure there are no air gaps around the door. If door seal is damaged, replace it.
Setpoint too high	Lower the setpoint
Evaporator coil is frosted or iced up	Observe ice formation pattern. If only part way up the coil face, evaporator unit could be low on refrigerant. If so, contact your installing technician to assist with troubleshooting.
System runs constantly	
Possible cause	Solution
Leaky door seal or poorly insulated cellar	Fix leaky door seal and insulate cellar

Unit leaks water

Possible cause	Solution
Evaporator unit is not level	Evaporator unit should be level on the wall to prevent leaking
Drain line clogged or kinked	Check drain line to make sure water can flow freely
Drain is clogged, preventing water from escaping	Disconnect drain and clear it out; check drain for blockage
Drain line does not have a downward slope	Fix drain line so there is a downward slope from the unit to the drain
Coil is iced, causing drain pan to freeze and water to overflow	Melt ice with blow drier. Soak up with a towel.
Condensate pump needs to be reset	Disconnect and reconnect the black cables attached to the pump

Unit runs but does not cool

Possible cause	Solution
Lack of air flow	Make sure fan is unobstructed and that the evaporator filter, evaporator coil, and condenser coil are clean and free of debris
System undersized	Contact Customer Service at 1-800-343-9463
Compressor is overheating	Shut system off for 1 hour to allow compressor to cool. Turn back on and check for cooler air flow out. If compressor runs, check for and clean condenser coil as possible cause of compressor overheating. If problem repeats, contact you installing technician to assist with troubleshooting.

Evaporator fan runs but compressor does not

Possible cause	Solution
Running an Anti-Frost Cycle	1) If the system is maintaining the correct cellar temperature and there is a dripping snowflake symbol illuminated on the control, the system is going through an Anti-Frost Cycle. No action is required. 2) If the system is not maintaining the correct cellar temperature, this may be due to a dirty evaporator filter or coil. 3) Call installing technician to troubleshoot, as the system may be low on charge or require an adjustment to the TXV.
Compressor and/or starting components faulty	Please contact the installing technician to troubleshoot
System may be performing the WHM function	Allow cooling system to revert back to cooling mode
Compressor may have overheated	Shut system off for 1 hour to allow compressor to cool. Turn back on and check for cooler air flow out. If compressor runs, check for and clean condenser coil as possible cause of compressor overheating. If problem repeats, contact your installing technician to assist with troubleshooting.

Compressor runs but evaporator fan does not

Possible cause	Solution
Faulty fan motor	Please contact the installing technician to troubleshoot
Faulty controller	Please contact the installing technician to troubleshoot

Compressor short cycles

Possible cause	Solution
Evaporator unit blows on bottle probe	Move bottle probe to a more central location
System low on refrigerant charge	Please contact the installing technician to troubleshoot
Condensing fan motor/capacitor faulty	Please contact the installing technician to troubleshoot
Compressor and /or starting components faulty	Please contact the installing technician to troubleshoot

Humidity in cellar too low

Possible cause	Solution
Not enough moisture	Purchase and place a humidifier (or a decorative fountain) in cellar

Condenser Component Identification

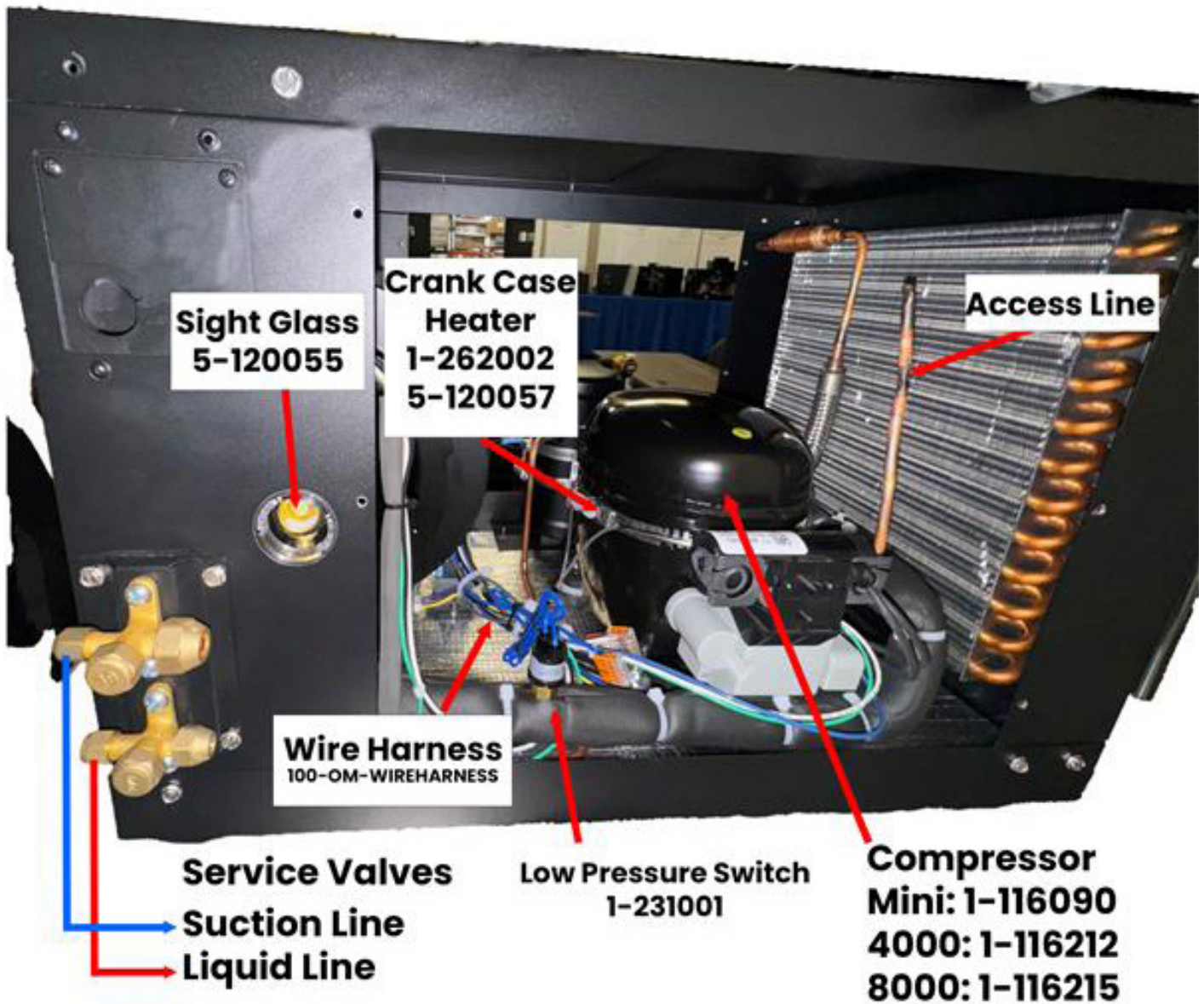

Omega Mini

5-120007: Suction Service Valve, 3/8"
5-120006: Liquid Service Valve 1/4"

Omega 4000/8000

5-120021: Suction Service Valve, 1/2"
5-120006: Liquid Service Valve 1/4"

Condenser Component Identification

Condenser Coil Mini: 2-121211
Condenser Coil 4000/8000: 2-110801

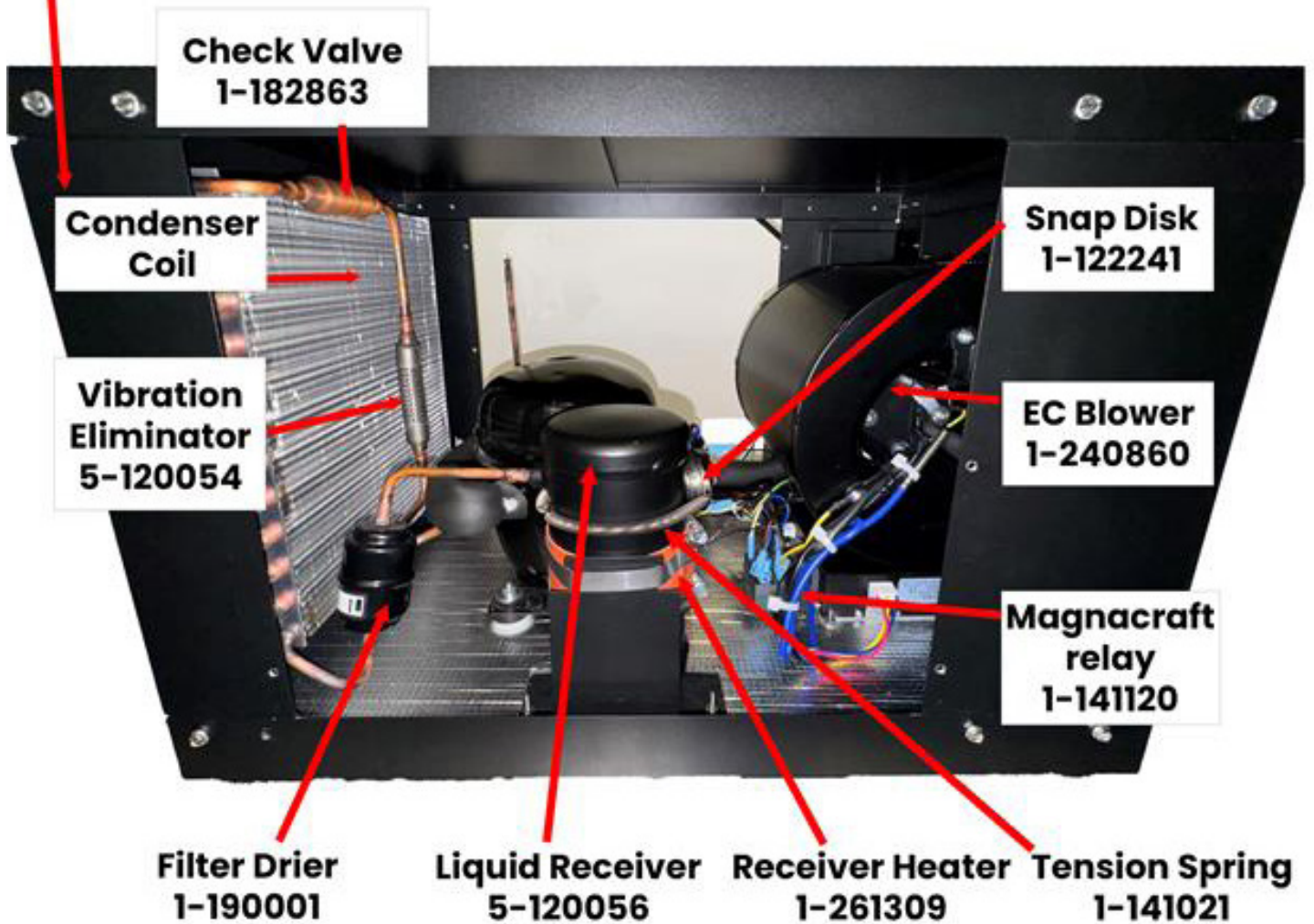

SYSTEM OPERATION- KDT

Initial Start-Up

When the unit is plugged in and power is sent to the controller, a beep will sound, confirming that the controller is getting power. All LEDs on the display will blink three times. Three dashes will then appear on the screen. All display LEDs will then blink three times. Once the controller has gone through the initial startup process, and all LEDs have cycled, the home screen will be displayed.

Setpoint

The setpoint is preset at the factory to 55°F. It can be adjusted by the customer between 50–70°F in one-degree increments.

Indoor Fan Operation

The indoor fan will run when the controller is calling for cooling and turn off once the cooling cycle has ended. During the cooling cycle, the system will remove some relative humidity from the cellar. Some of the humidity that was removed can be reintroduced into the cellar by adjusting the “fan on” and “fan off” functions. (The cooling system is not equipped with a humidifier and does not add humidity.)

The FOF cycle should be shortened first. This will reduce the amount of time that the fan remains off following a cooling cycle. When the unit has completed a cooling cycle, the compressor and the condenser fan will turn off, but the indoor fan will continue to run for whatever length of time the customer has set. The Fon function may then be lengthened to allow the fan to run longer and reintroduce moisture from the evaporator coil back into the wine cellar.

For more information about fan settings, refer to the User Menu

Anti-Short Cycle

The Anti-Short Cycle ensures that the unit will remain off for a period of five minutes after the unit has reached the setpoint. This allows the pressure in the refrigeration system to equalize prior to starting the compressor.

Once the solenoid relay is de-energized, the controller must wait five minutes before reenergizing the relay. This prevents the compressor from repeatedly turning off and on. If the unit is calling for cooling during this time, the compressor icon will blink, indicating that cooling is needed but the controller is waiting for the Anti-Short Cycle delay.

Anti-Frost Cycle

When the evaporator probe senses a temperature of 26°F for a duration of one minute, an Anti-Frost Cycle will be initiated. This will shut down the compressor, allowing the evaporator fan to run and melt any frost accumulation on the coil. While the Anti-Frost Cycle is running, “dEF” will be displayed on the screen. The compressor will remain off until the evaporator coil reaches 40°F, or for a maximum of one hour. The unit will then return to normal operation.

Digital Display

The display is designed to give the user the ability to adjust the setpoint, Fon/FOF parameters, and other settings. (See User Menu for more details.) The bottle probe temperature is displayed by default. “dEF” will be displayed during an Anti-Frost Cycle. The bottle probe and evaporator probe temperatures can be accessed by pushing the SET button and scrolling through “Pb1” (bottle probe) and “Pb2” (evaporator probe). The light button may be used as an unlock button.

Safety Features

In the event of a faulty bottle probe, the compressor will cycle off for 10 minutes and on for 40 minutes. “E1” will be displayed on the screen.

Alarms

See “Alarm Codes” in the Controller Functions chart.

SYSTEM OPERATION- 24V

Initial Start-Up

Set the thermostat to COOL and fan switch to AUTO. Lower the setpoint to the desired cellar temperature. (A temperature of 55°F is the recommended setpoint.) See thermostat instructions for details.

Indoor Fan Operation

The indoor fan will run when the controller is calling for cooling and turn off once the cooling cycle has ended. During the cooling cycle, the system will remove some relative humidity from the cellar. Some of the humidity that was removed can be reintroduced into the cellar by adjusting the “fan on” and “fan off” functions. (The cooling system is not equipped with a humidifier and does not add humidity.)

The FOF cycle should be shortened first. This will reduce the amount of time that the fan remains off following a cooling cycle. When the unit has completed a cooling cycle, the compressor and the condenser fan will turn off, but the indoor fan will continue to run for whatever length of time the customer has set. The Fon function may then be lengthened to allow the fan to run longer and reintroduce moisture from the evaporator coil back into the wine cellar.

For more information about fan settings, refer to the User Menu

Anti-Short Cycle

Most thermostats have a safety feature that will prevent the condensing unit from cycling on and off within a short period of time. During the anti-short cycle, the condensing unit will typically remain off for 5-7 minutes. See thermostat instructions for details.

Operation in Low Ambient Temperatures

The condensing unit comes equipped with a fan cycle switch, which controls the condenser fan operation to maintain optimal system pressures. During cold ambient temperatures when the high side pressure falls below 75 psi, the fan cycle switch will open and the condenser fan will be shut off to maintain minimum head pressure. Once the pressure reaches 110 psi, the fan cycle switch will close and allow the condenser fan to continue operation.

MAINTENANCE SCHEDULE

<p>Monthly</p>	<ol style="list-style-type: none"> 1. Check for debris surrounding condensing unit (leaves, branches, trash, etc); remove all obstructions. 2. Check the drain line to see if it is above the waterline (if draining into a vessel) Inspect the external drain line for functionality. Moisture should be present inside of the drain line if system has been running. If uncertain, remove the evaporator grille and pour water into the drip pan to engage the condensate pump.
<p>Bi-Annual</p>	<ol style="list-style-type: none"> 1. Use a vacuum with brush attachment or compressed air to clean the evaporator coil; be careful not to crush coil fins when cleaning, clean condensing coils also. 2. Remove the evaporator filter and clean with warm water. 3. Ensure the condensing unit is free of debris and dust. 4. Have a certified HVAC-R technician service the condensing unit and clean the condenser coil.
<p>Annually</p>	<ol style="list-style-type: none"> 1. Inspect for corrosion 2. Check wiring connections and integrity of cords 3. Blow out drain line with air to clear any debris or buildup.
<p>Quarterly (Ceiling Mount Units Only)</p>	<p>Clean out drip pan inside evaporator</p> <ol style="list-style-type: none"> 1. Use a Phillips screwdriver to remove screws from evaporator grille and detach the grille. 2. Locate the two thumb screws on side walls of evaporator connected to the drip pan brackets and twist with fingers to unscrew. NOTE: For Mini, use screwdriver to remove screws. 3. Remove drip pan from evaporator and clean inside pan with soap & water using a sponge. 4. Inspect pump reservoir for sludge or debris before replacing pan and clear out if needed. 5. Once pan is back in place, pour water into pan to test function of the pump. (Power must be on for this). 6. Once pump function has been verified, drop Air Conditioning Pan Tablet inside of pan, then replace grille with screws.

TECHNICAL ASSISTANCE

WhisperKOOL Customer Service is available Monday through Friday from 6:00 a.m. to 4:00 p.m. Pacific Standard Time.

The appointed customer service representative will be able to assist you with your questions and warranty information more effectively if you provide them with the following:

- The model and serial number of your WhisperKOOL system(s).
- Location of unit and installation details, such as ventilation, ducting, construction of your wine cellar, and room size.
- Photos of the cellar and installation location may be needed.

Contact WhisperKOOL Customer Service

1738 E. Alpine Ave
Stockton, CA, 95205
www.whisperkool.com

Email: support@whisperkool.com
Fax: 209-466-4606

ACCESSORIES FOR COOLING UNITS

WhisperKOOL offers accessories to enhance and customize your wine cooling unit:

Little Giant Condensate Pump Kit

The condensate pump kit automatically removes water that drips out of the evaporator unit's drain line. The pump is controlled by a float/switch mechanism that turns the pump on when approximately 2¼" of water collects in the tank, and automatically switches off when the tank drains to approximately 1¼". The condensate pump kit allows the excess condensate to be pumped up to 20 feet away from the unit.

Accessories can be purchased at www.whisperkool.com

**WhisperKool Product Terms and Conditions
Including Product Limited Warranty And Product Installation Requirements
For WhisperKool Split System Series**

ATTENTION: PLEASE READ THESE TERMS OF USE CAREFULLY BEFORE INSTALLING YOUR WHISPERKOOL COOLING SYSTEM. INSTALLING YOUR WHISPERKOOL COOLING SYSTEM INDICATES THAT YOU ACCEPT AND AGREE TO EACH OF THE TERMS AND CONDITIONS SET FORTH HEREIN ("TERMS OF USE"). IF YOU DO NOT ACCEPT THESE TERMS OF USE, YOU RISK VOIDING YOUR WARRANTY AND ASSUMING ADDITIONAL REPAIR AND REPLACEMENT COSTS.

1. Purchase of a WhisperKool Cooling System assumes that the Purchaser ("End User") fully accepts and agrees to the Terms and Conditions set forth in this document. The Terms and Conditions of Sale and Owner's Manual are shipped with each unit and, if another copy is needed, replacement copies can be downloaded from the company website (WhisperKool.com) or by contacting WhisperKool directly for a new copy. WhisperKool reserves the right, in its sole discretion, to change its Terms and Conditions at any time, for any reason, without notice.

2. WhisperKool Product Installation and Limited Warranty

- A. Purchaser of the product must arrange for the product to be installed by a certified HVAC/R technician in accordance with procedures set forth by WhisperKool and described in the WhisperKool Owner's Manual.
- B. The HVAC/R technician installing the product must complete the designated portion of the Split Startup Checklist and provide licensing or certification identification number information to assist in the warranty registration process.
- C. Purchaser must return the completed Split Startup Checklist to WhisperKool within thirty (30) days of installation of Product. The Split Startup Checklist must be approved by WhisperKool to activate the Limited Warranty. If the Split Startup Checklist is approved, Purchaser will be sent activation approval documents and will start receiving the benefits of the Limited Warranty throughout the warranty period. If the Split Startup Checklist is incomplete, Purchaser will be informed they have five days to complete the Split Startup Checklist and re-submit to WhisperKool. The Split Startup Checklist will be reviewed again, and if denied, Purchaser will be informed that they have 10 business days for corrective action. Failure to register the Product may result in loss of warranty.
- D. Purchaser is responsible for the full costs of installation and any additional parts required for the proper and complete installation of the product.
- E. For Split Systems returned to WhisperKool in accordance with the terms and conditions of the Limited Warranty, WhisperKool warrants against defects in material and workmanship as follows:
 1. **LABOR** —For a period of two (2) years commencing on the date of purchase and up to an additional (1) year grace period upon approved startup checklist, WhisperKool will, at its option and discretion, reimburse up to \$400 to the End User for cost incurred for repairing, removing or installing warranty parts. Invoice for service must be forwarded to WhisperKool for assessment and processing. The Split System warranty is invalid if there is attempted repair by anyone other than an HVAC/R technician approved by WhisperKool to service the Product.
 2. **PARTS** — For a period of two (2) years commencing on the date of purchase and up to an additional (1) year grace period upon approved startup checklist, WhisperKool will supply, via a deposit, new or rebuilt replacement parts in exchange for defective parts. Replacement parts are warranted only for the remainder of the original warranty period.
 3. **UNIT** - WhisperKool will replace the Product with an authorized factory replacement under the terms of our Replacement Agreement via a deposit. The Replacement Agreement outlines the terms, procedures, and additional considerations should the End User request a replacement for a cooling unit that is found to fall under warranty. For more information on our Replacement Agreement, visit www.WhisperKool.com/warranty-information.

The following part or cause of failure is not the responsibility of WhisperKool:

- Improper voltage supply
- Line set with screw connectors (high end and low end)
- Leaks found at the braze points when performing pressure check
- Unit that has been charged incorrectly
- Incorrect tubing diameter used on line set
- A unit that has been wired incorrectly
- Valve stem on condenser side
- Improper installation of P-Trap
- Lack of P-Trap (if required)
- Condensers that are installed outdoors or in elements that would affect operation without proper cover or housing. (Housing is available from Manufacturer).

Product Warranty Limitations and Exclusions.

1. This limited warranty does not cover cosmetic damage caused during installation, damage due to acts of God, commercial use, accident, misuse, abuse, negligence, or modification to any part of the Product. Delivery and installation of the Product, any additional parts required, as well as removal of the Product if warranty work is required, are all at the sole cost, risk and obligation of the End User.
2. This limited warranty does not cover damage due to improper installation or operation or lack of proper maintenance of the Product, connection of the Product to improper voltage supply, or attempted repair of the Product by anyone other than a technician approved by WhisperKool to service the Product.
3. This limited warranty does not cover any Product sold "AS IS" or "WITH ALL FAULTS."
4. Product that has been replaced during warranty period does not extend the warranty period past the original date of purchase.
5. This limited warranty is valid only in the continental United States. Sales elsewhere are excluded from this warranty.
6. Proof of purchase of the Product in the form of a bill of sale, receipted invoice or serial number, which is evidence that the Product is within the Limited Warranty Period, must be presented by the End User to WhisperKool in order to obtain limited warranty service.
7. This limited warranty is void if the factory applied serial number has been altered or removed from the Product.
8. This limited warranty is voided if installed in an enclosure of insufficient design that does not follow the Product installation requirements stated herein and in the owner's manual.
9. Removing the rivets from the Product's unit housing without prior authorization from WhisperKool voids this limited warranty.
10. The End User must first contact WhisperKool Customer Service by telephone (at 1-800-343-9463) prior to attempting service on any Product still under the limited warranty; else the limited warranty is voided.
11. This limited warranty does not cover Product being concealed by, but not limited to, vegetation, fabric, shelving, mud, snow, or dirt. Product must not be painted or limited warranty will be void.
12. This limited warranty does not cover exposure to corroding environments such as, but not limited to, petroleum and gasoline products, cleaning solvents, caustic pool chemicals, and marine air.
13. This limited warranty does not cover any cause not relating to Product defect.
14. THE REPAIR OR REPLACEMENT OF THE PRODUCT AS PROVIDED UNDER THIS LIMITED WARRANTY IS THE EXCLUSIVE REMEDY OF YOU, THE END USER, AS WELL AS ANYONE ELSE IN THE CHAIN OF TITLE OF THE PRODUCT, DOES NOT START A NEW LIMITED WARRANTY TIME PERIOD, AND IS IN LIEU OF ALL OTHER WARRANTIES (EXPRESS OR IMPLIED) WITH REGARD TO THE PRODUCT. IN NO EVENT SHALL WhisperKool BE LIABLE FOR INCIDENTAL, CONSEQUENTIAL, SPECIAL OR CONTINGENT DAMAGES FOR BREACH OF ANY EXPRESS OR IMPLIED WARRANTY ON THIS PRODUCT. THE IMPLIED WARRANTIES OF MERCHANTABILITY
15. AND FITNESS FOR A PARTICULAR PURPOSE ARE HEREBY EXPRESSLY DISCLAIMED. Some states do not allow the exclusion or limitation of incidental or consequential damages, or allow limitations on how long an implied warranty lasts, so the above limitations or exclusions may not apply to you. This limited warranty gives you specific legal rights, and you may have other rights, which vary from state to state.

16. Failure of the End User to comply with all of the Product Installation Requirements, Maintenance Requirements and End User Requirements may, at WhisperKool's sole discretion, void this limited warranty.

17. No one has any authority to add to or vary the limited warranty on this Product.

3. Maintenance Requirements

The End User is responsible for checking the coils on the condenser unit and vacuuming them every three months to maintain them free of debris. It is the End User's responsibility to clean off any accumulated dust, lint, or other debris from the front and rear intake grills; failure to do this on a regular basis will restrict the airflow and may affect the Product's ability to function properly. Periodically cleaning the Product's vents will help assure maximum cooling efficiency. The drain tube must also be checked and kept clean and free of debris and mold to maintain proper performance.

Mold is a natural living organism in the environment. It exists in the air in the form of microscopic spores that move in and out of buildings through doors, windows, vents, HVAC systems and anywhere else that air enters. Once it is discovered, mold must be addressed quickly and appropriately. Delayed or improper treatment of mold issues can result in costly and reoccurring repairs. If the End User suspects a mold problem, it is always best to hire a qualified and experienced mold remediation specialist.

4. Additional End User Costs And Responsibilities

Terms and conditions for replacing the Product that is being evaluated for limited warranty.

1. After evaluation by a certified HVAC/R technician and the Product is found to be irreparable in the field, contact WhisperKool Customer Service to arrange for replacement under the warranty guidelines. When a claim for warranty is submitted for a condenser skid, the End User must purchase a new condenser skid from WhisperKool at retail price. Upon installation of the new condenser skid by a certified HVAC/R Technician, the HVAC/R Technician must complete the Installation Checklist and End User must submit the Installation Checklist to WhisperKool Customer Service for approval. The original condenser skid must be returned within 21 days to WhisperKool for failure analysis. If the Installation Checklist is approved and the failure is evaluated as defective and not installation error or other reason, the End User will be refunded for the cost of the replacement skid.
2. If the Product failure is evaluated and it is determined that it is an installation error or other reason, all costs, including shipping will be the responsibility of the End User.

The following items are not covered under any warranty and are the sole responsibility of the End User:

- A. End Users should satisfy themselves that the Product they are purchasing is suitable for their particular needs and requirements, and thus no responsibility will be placed with WhisperKool for the End User's decisions in this regard.
- B. End Users must assure that the product is installed by a certified HVAC/R technician. Failure to do so will result in Voiding the Limited Warranty.
- C. It is the End User's responsibility to secure safe haven/storage for ANY AND ALL items that are being kept and stored in the End User's wine cellar, including any Product. WhisperKool takes no responsibility for the safety and preservation of the aforementioned items in the event that the environment becomes unsuitable to maintain a proper storage environment.
- D. End User is responsible for initial installation costs, including, but not limited to, labor costs and the cost of any additional parts necessary to complete the installation.
- E. End User is responsible for all costs incurred for the installation and/or removal of the Product, or any part thereof, unless such cost has been agreed by WhisperKool to be a warranty repair prior to the work being performed.

5. Sales and Use Tax

WhisperKool only collects California sales tax for orders shipped within the State of California; WhisperKool does not collect sales tax for orders shipped to other states. However, the Purchaser and the End User may be liable to the taxing authority in their state for sales tax and/or use tax on the Product. The Purchaser and the End User should each check with their state's taxing authority for sales and use tax regulations.

6. Customer Service and Troubleshooting

WhisperKool's customer service department is available to answer any questions or inquiries for End Users regarding a WhisperKool Product, as well as to assist in performing basic troubleshooting, Monday through Friday, from 6:00 a.m. to 4:00 p.m. PST, at Support@WhisperKool.com. WhisperKool reserves the right to have a certified, WhisperKool-approved, HVAC/R technician go on site and inspect the product if the initial trouble shooting warrants further investigation. WhisperKool Corporation is located at 1738 East Alpine Avenue, Stockton, California 95205.

7. Request for Product Evaluation and Repair Under Warranty

SPLIT SYSTEM FIELD SERVICE WARRANTY POLICY: This Policy is to clarify what falls under Warranty Service and what becomes the responsibility of the Owner. WhisperKool (“manufacturer”) strives to provide our customers with a superior Product and we back our Product with a Two Year Limited Warranty. Please review the WhisperKool Product Terms and Conditions including Product Limited Warranty and Product Installation Requirements to ensure you have a complete understanding of our Policy and coverage of your Split System.

ARBITRATION: Any disputes arising out of or in connection with the installation and warranty of the Split System shall be referred to and finally resolved by a WhisperKool approved Independent Certified HVAC/R Technician. The evaluation of the Technician on all issues or matters of identifying the responsible party (WhisperKool or Installing Technician) shall be determined in a written report. This report will be made available to all concerned parties. If discovered under warranty, WhisperKool will assume the financial responsibility under their warranty guidelines. If the report finds the Owner’s Installer as the responsible party, WhisperKool will provide all documentation to the customer to substantiate the findings. This will include the Invoice from the Independent Certified HVAC/R Technician and the written report of the findings. The Owner will become responsible for payment directly to WhisperKool for all charges incurred for repairs (labor, parts and shipping costs) on the Split System.

8. Miscellaneous Terms and Conditions

- A. Return Policy. All return inquiries must be made within ninety (90) calendar days of the original purchase of a Product and are subject to a twenty five percent (25%) restocking fee. Shipping costs are not refundable and the Purchaser is responsible for all return shipping costs (including customs fees and duties, if applicable).
- B. Security Interest. WhisperKool retains a security interest in each Product until payment in full.
- C. Construction and Severability. Every provision of these Terms and Conditions shall be construed, to the extent possible, so as to be valid and enforceable. If any provision of these Terms and Conditions is held by a court of competent jurisdiction to be invalid, illegal or otherwise unenforceable, such provision will, to the extent so held, be deemed severed from the contract of sale between Purchaser and WhisperKool, and all of the other non-severed provisions will remain in full force and effect.
- D. Governing Law/Choice of Forum. The laws of the State of California (without regard for conflicts of law) shall govern the construction and enforcement of the these Terms and Conditions of Sale (Sections 1 through 9 inclusive, including Product Limited Warranty And Product Installation Requirements), and further these Terms and Conditions of Sale shall be interpreted as through drafted jointly by WhisperKool and Purchaser. Any dispute will be resolved by the courts in and for the County of San Joaquin, State of California, and all parties, WhisperKool, Purchaser and End User, hereby irrevocably submit to the personal jurisdiction of such courts for that purpose. No waiver by WhisperKool of any breach or default of the contract of sale (including these Terms and Conditions of Sale) concerning a Product will be deemed to be a waiver of any preceding or subsequent breach or default.
- E. Correction of Errors and Inaccuracies. These Terms and Conditions may contain typographical errors or other errors or inaccuracies. WhisperKool reserves the right to correct any errors, inaccuracies or omissions, and to change or update these Terms and Conditions, at any time without prior notice.

9. Questions, Additional Information And Technical Assistance

- A. Questions. If you have any questions regarding these Terms and Conditions or wish to obtain additional information, contact us at Support@WhisperKool.com or please send a letter via U.S. Mail to:

Customer Service
WhisperKool Corporation
1738 E Alpine Ave
Stockton, CA 95205

E-mail: support@WhisperKool.com
Web: www.WhisperKool.com

- B. Technical Assistance. WhisperKool Customer Service is available Monday through Friday from 6:30 a.m. to 4:00 p.m. PST. The Customer Service representative will be able to assist you with your questions and warranty information more effectively if you provide them with the following:
 - 1. The model and serial number of your WhisperKool UNIT.
 - 2. The location of the system and installation details, such as ventilation, construction of your wine cellar, and room size.

Replacement Agreement

WhisperKOOL will replace the item(s) with the same or compatible item(s) for products that fail within warranty. Before initiating a warranty claim, the customer must complete all troubleshooting steps and the warranty claim process with a customer service representative.

Terms and Conditions

1. The customer will be charged a deposit to replace and ship the item via standard ground shipping under warranty. The total deposit amount will depend on the item being replaced. The customer is responsible for all shipping costs to and from the facility and any cost associated with the removal or reinstall of the product.
2. For Unit Replacements:
 - a. The cellar must be constructed per the guidelines in the Owner's Manual; an adequately built wine cellar must be fully insulated and include a completely sealed vapor barrier that will prevent excessive moisture from entering the wine cellar.
 - b. The cooling unit must be installed with no obstruction to the airflow. Adequate ventilation is required to dissipate heat away from the unit.
 - c. The condenser intake air temperature must not exceed the maximum recommended by WhisperKOOL.
 - d. The customer must install the external drain line to dispel the condensate.
 - e. **Warranty will be void if the unit is not installed, operated, maintained and serviced in accordance with instructions issued by WhisperKOOL, and a replacement will not be covered.**

Required Procedures

- An RMA (Return Merchandise Authorization) number will be issued at the time of the order.
 - Once the replacement item has been received and installed, use the new packaging to re-pack the original item and ship it back to the factory.
 - The customer is responsible for the return shipping of the item.
 - We recommend that you insure your shipment to cover any potential losses or damages that may occur during the shipping process.
 - Please fill out the credit card information below to complete the Replacement Agreement. **Providing a major credit card is a requirement of completing this agreement.**
 - Your credit card will be pre-authorized for the total deposit and charged when the replacement order is shipped and invoiced.
- **If you fail to return the original WhisperKOOL unit or part to the factory within 30 days, or no problem is found with the product, you will not be eligible for a refund.**
- All orders covered by warranty will receive a partial or full refund after evaluation has been completed and the claim has been verified, excluding items not covered under warranty, additional fees associated with the claim, and any expedited shipping charges associated with the order.

Additional Considerations

- This program is only for existing WhisperKOOL units under warranty.
- Replacement units are subject to availability. Your size replacement may not be available at all times.
- Refurbished cooling units may also have minor cosmetic imperfections.
- Factory-Authorized Replacements have been tested and are in proper operating condition at the time of shipment.
- The customer's responsibility is to secure haven/storage for ANY AND ALL items kept and stored in their wine cellar. WhisperKOOL takes no responsibility for the safety and preservation of the items mentioned above if the environment becomes unsuitable to maintain a proper storage environment.
- If you have any questions or require further assistance, please contact our Customer Service Department at 1-(800) 343.9463 or email at support@whisperkool.com.

WARRANTY REGISTRATION

In order to activate the warranty of your system, the verification and operational documentation must be completed by the certified refrigeration technician installing your system and submitted via mail, fax, the website, or e-mail.

Mail to:

WhisperKOOL
ATTN: Warranty Registration
1738 E. Alpine Avenue
Stockton, CA 95205-2505
USA

Fax to:

209-466-4606

Scan and email to:

warranty@whisperkool.com



Model _____ **Serial Number** _____

Installed by _____ **Date** _____

*Whisper***KOOL**[™]

WhisperKOOL
1738 E. Alpine Ave
Stockton, CA 95205
1-800-343-9463
www.whisperkool.com