



Vigilant Guardian 10, 100 & 150 Humidification Systems

Operating Instructions





Guardian Humidification Systems Operating Instructions

Congratulations! You have purchased the finest cigar humidification system ever created for the preservation of premium cigars. The Guardian Humidification System has been designed to provide your premium cigars with the optimal storage environment. The Guardian microprocessor constantly monitors the humidity level of your cabinet interior and will maintain the relative humidity (RH) to within 2% of your desired setting.

Should you have any questions regarding the installation or operation of Vigilant's Guardian Humidification System, please call us toll-free at 888-812-4427. We will be happy to assist you.

Please read this entire manual before operating your Guardian Humidification System. By following these instructions, you will guarantee the proper conditions for your prized cigar collection.

Parts

- Humidification system – consists of water reservoir, controller, and sensor
- Zip ties (2)
- Wire anchors (5)
- 24-volt wall adapter
- Wicking filter (located inside system)



Guardian 10 model



Guardian 100/150 model



Installation and Start-Up Operation

IMPORTANT:

- DO NOT OVERFILL THE RESERVOIR AS OVERFILLING WILL CAUSE DAMAGE TO YOUR CABINET!
 - DO NOT POUR WATER ON THE FAN THIS CAN CAUSE DAMAGE TO THE ELECTRONICS.
 - DO NOT MOVE CABINET WITH WATER IN IT.
1. Remove all packing material from the reservoir area and make sure the parts list is complete. Leave the white mesh wicking filter in the reservoir.
 2. Place the Guardian Humidification System in the bottom of your cabinet.
 3. Insert the small end of the power cord through a hole in your cabinet and plug it directly into the power jack on the side of the controller of your system.
 4. Placement of sensor: Determine a suitable location for the sensor, preferably two-thirds up from the back panel or side wall, and/or as close to the horizontal center of the back panel as possible.
 5. Extra support for the sensor can be gained using the included wire anchors and zip ties.
 6. Slowly fill the reservoir with distilled water to the max fill line. The reservoir is outfitted with an overflow vent that will prevent damage to your system. Make sure that the white mesh wicking filter is sitting vertically upright in your reservoir.
 7. Plug your humidification system into a surge protector that is attached to a grounded outlet. The digital display will activate within 6 seconds and a 10-minute stabilization program will begin.
 8. Next, the unit will automatically begin to operate at the **factory set point of 67% relative humidity**. Allow the unit to run at the factory set point for at least 24 hours before making adjustments.
 - The system will use large amounts of water during the first several days of operation. Once the humidor has been seasoned (3 – 4 days), water use will greatly diminish.
 - It is recommended that you do not set the humidity level above 70%, as cigars stored at humidity levels higher than 72% can become soft and moldy.
 - If you choose to make an adjustment to the humidity level, limit the change to no more than 2% in a 10-day period.



Adjusting the Humidity

Your Guardian Humidification System has been pre-set at 67% relative humidity and operates on a range (hysteresis) of approximately 2%. The system, therefore, will operate between 66% and 68%, as set. As the control system is fully automatic, the only control feature you need to be familiar with is the set point adjustment.

Your system should be run at the pre-set level – with cigars in the cabinet – for at least two weeks before adjusting the humidity. If you choose to make an adjustment, limit the change to no more than 2% in a 10-day period.

PLEASE NOTE: Loading the cabinet with moist cigars may temporarily bring the relative humidity above the set point range on the system.

The digital display will indicate the actual humidity level inside of your humidor. To view and/or adjust the set point, read this manual completely before proceeding then simply follow these steps:

1. Press the far-left circle arrow key to view the current set point.
2. To adjust humidity upward, tap the ↑ key until desired level of humidity is reached.
3. To adjust humidity downward, tap the ↓ key until desired level of humidity is reached.

Maintenance of Reservoir and Wicking Filter

When the red LED low water indicator is on, it is time to fill the water reservoir. Frequency of filling will vary depending on climatic conditions and cabinet size.

As the reservoir and wicking filter(s) are constantly exposed to moisture and dirt collected from the circulating air, they must be cleaned periodically. We recommend that you clean the reservoir and filter each time you add distilled water.

1. Unplug the system from its power outlet before you begin cleaning the reservoir and filter.
2. Remove the humidification system from your cabinet, being careful not to spill any water on your humidor. Remove the thumbscrews, lift the cover off and remove the filter.
3. Wipe the walls of the reservoir with a damp paper towel
4. Wicks should be changed every 90-120 days and can be ordered directly from Vigilant's online store at <http://shop.vigilantinc.com/>.
5. Insert clean filter into the reservoir and return it to your cabinet.
6. To fill the reservoir, add DISTILLED water through grommet opening. Never overflow the reservoir. Watch the water level carefully while filling. Slowly fill reservoir to the max fill line.



Suggestions

The installation and maintenance of your Guardian Humidification System will directly affect its performance. Here are some factors to consider:

- Do NOT block the system fan airflow. Shelves or boxes of cigars should be at least 4" above the fan.
- Do NOT block the sensor by stacking boxes or other impediments in front of it.
- Keep the water reservoir and wicking filter clean by servicing at least every 90-120 days.
- Avoid frequent opening of your cabinet door(s). If the humidor is used for commercial environments, nighttime recovery will be crucial for maintaining an optimal environment.

TROUBLESHOOTING

Cabinet appears not to maintain desired humidity level

- Check the set point adjustment by tapping the far-left key on the control panel. If the set point is not at your desired relative humidity level, reset by following the "Adjusting the Humidity" instructions.
- Check the seal(s) of the door(s) and drawer(s) of your cabinet. The system may not be able to maintain adequate humidity levels in a cabinet that is not airtight.
- Check the water level in the reservoir. If it is empty, the red LED should be lit. If not, carefully fill your reservoir to approximately 1" below the overflow hole.
- Be certain that fan and airflow intake are clear of any obstructions that could impede air circulation.
- Verify that the wicking filter is vertically positioned inside the reservoir.

Cigars are too moist or too dry

- Your humidity set point is too high or too low.
- Remember that the system will run up to 2% above the set point. It is recommended that the system is started at the pre-set level of 67% RH to maintain an interior humidity level between 66-68%.

Fan does not work

- Check power source and connections.
- If the set point is below the humidity level of the cabinet's interior, the fan will not run.
- Press the far-left button on the control panel to check set point.

If these troubleshooting recommendations do not correct the problem, call Vigilant at 888-812-4427 and a service representative will gladly assist you.



ADDENDUM – photos & additional instructions

POWER STABILIZATION MODE



The Guardian sensor requires a stabilization period of up to 30 minutes upon powering. When the control is first powered it will default to stabilization mode.

This mode will delay operation for 10 minutes and the fan will be OFF.

During this mode the display will flash “STB” and the current sensor reading.

Initially the sensor will read near zero. After a short period (less than 15 seconds), the sensor output will begin to increase. The final stabilization time will depend on the ambient conditions. The longest stabilization is required when the ambient parameter is near full scale, typically no longer than 30 minutes.

INDICATOR KEY



 Low Water (Auto-filling/Trouble)

 Humidifier Active

 Dehumidifier Active*

SP Displaying Current Set Point

((•)) Alarm

 Menu Access

 Raise



 Lower

*optional equipment



ADJUSTING SET POINT



- To view the current set point simply press the  button
- To adjust the set point simply use either the  or  buttons
- The adjustability range for cigar is 60-80% RH
- Factory set point is 67%

ALARMS



The Guardian control features a visual alarm indicator.

The alarm will illuminate if the relative humidity is too high or Low and will clear once the unit returns to the normal operating range.

- High Alarm $\geq 78\%$
- Low Alarm $\leq 62\%$

CONTROLLER INTERFACE CONNECTIONS

Power and interface connections

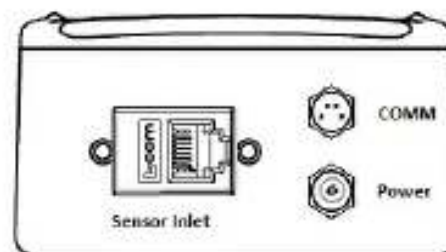
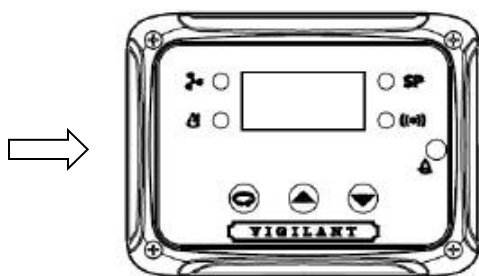

Side view

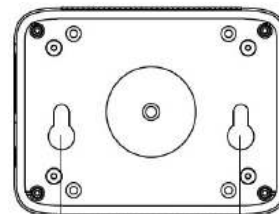

3"
Rear view



WIRES



Sensor assembly



DC power extension – 36"



Remote control wire (optional)

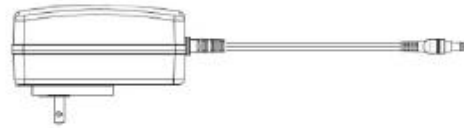

Power supply – 60"

FILTER ACCESS

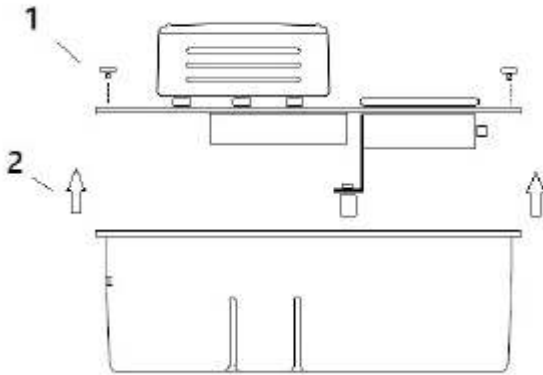

1. Remove thumb screws
2. Lift cover off

ADDING WATER

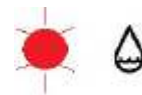
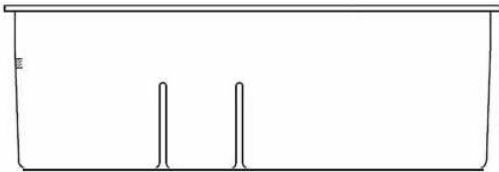

- The red LED light will indicate low water.
- Fill the reservoir with distilled water. Treat the water with Bacteriostat at this time if desired.
- DO NOT fill beyond the MAX FILL line.



CONTROLLER REMOVAL/ATTACHMENT

Controller can be detached from reservoir and mounted remotely. Contact Vigilant for optional remote control wires.

1. Slide the controller back on the mounts

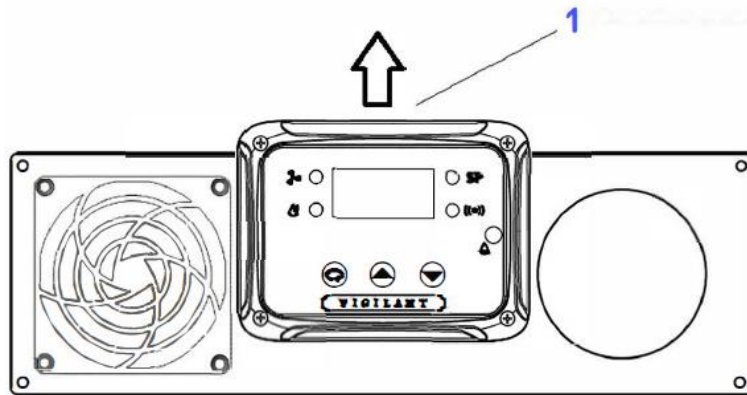

2. Lift the controller off the reservoir and press lever to disconnect the control wire

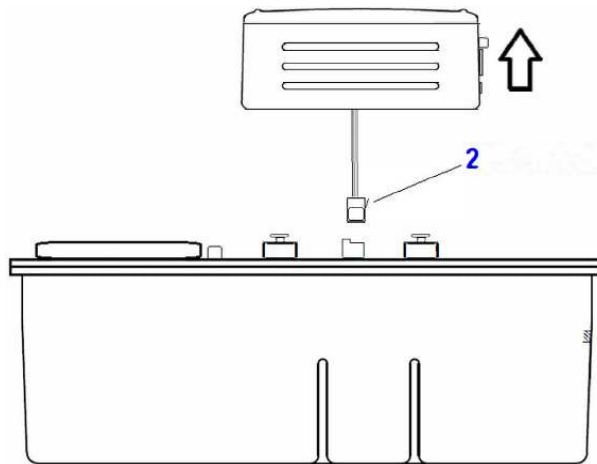

3. Tuck the control wire back into the housing

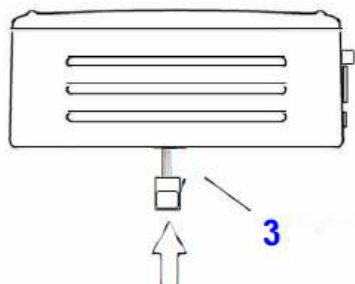



4. Locate the control wire inlets on both the controller and reservoir.
5. Push the remote control wire onto the inlet and thread clockwise to secure.

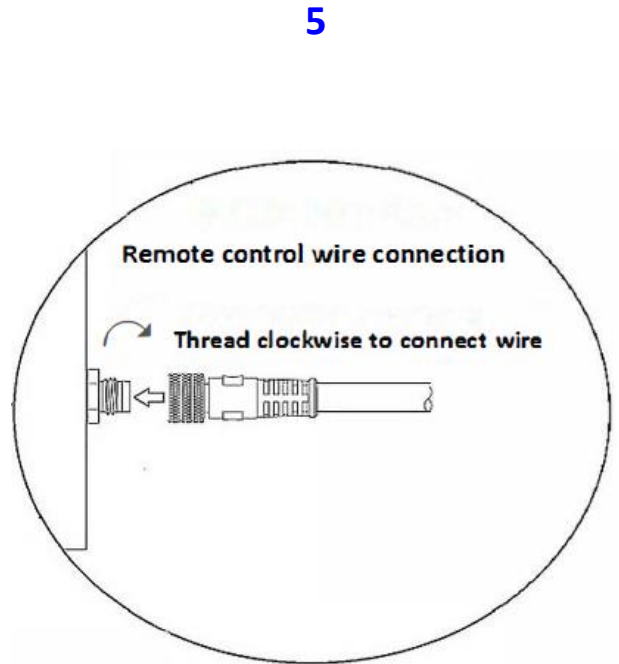
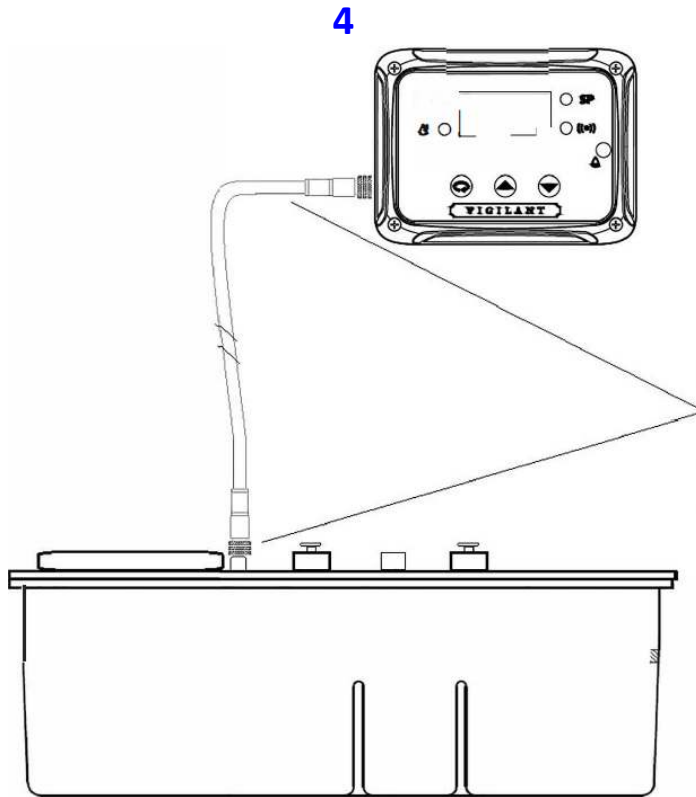

Warranty

Register your warranty online at vigilantinc.com/warranty

Vigilant Limited Two-Year Electronics Warranty

Upon registering your system with Vigilant, your Vigilant electronics are covered under our limited two-year warranty. All Vigilant electronic products are guaranteed to be free from defects in materials and/or workmanship for up to two years from date of purchase. Vigilant, at its sole discretion, may repair or replace defective components or products within this two-year period.

Any and all component(s) determined to be defective by Vigilant, must be returned at the owner's expense to Vigilant along with a copy of the original sales receipt.

Conditions to Vigilant's 2-Year Electronics Warranty

- Vigilant is not responsible for damage incurred during a product's return as a result of improper packaging. It is strongly suggested that all original packaging material from Vigilant be retained for returns.
- Vigilant is not responsible for any damage to property that results from the failure of a Vigilant product or product component.
- Vigilant warranty does not pertain to any customer-applied finishes, or any damage caused by neglect, abuse, misuse, improper operation, or unforeseen circumstances.
- Vigilant warranty is considered null and void if the online warranty registration is not completed within 60 days of receipt of your product.
- Vigilant warranty is non-transferable and valid for the original owner only.

Vigilant is a reseller for many fine products in the industry. Products resold by Vigilant carry the original manufacturer's warranty.

Please contact Vigilant at 888-812-4427 if you have any questions about your warranty. Learn more about our warranty details at vigilantinc.com/guarantee.